

# **US CUSTOMARY UNITS**

PIN: 2650.57

D040238

## **FEDERAL AID PROJECT**

Submitted in accordance with the Highway

---

# **PROPOSAL**

---

Law and the Standard Specifications officially finalized and adopted on May 1, 2024, as posted on New York State Department of Transportation's website.

Downtown Rome Wheel to Heels  
Streetscapes

Letting Time and Date:  
11:00 am, Thursday October 24, 2024

Letting Location:  
City of Rome  
City Hall  
198 Washington Street  
Rome NY 13440



EXPIRATION: 10/31/2025

## TABLE OF CONTENTS

Notice to Bidders	NTB-1 to NTB-3
Instruction to Bidders	ITB-1 to ITB-6
Supplemental Information Available to Bidders	SIAB-1
Non-Bidders Response	NBR-1
Bidder's Checklist	BC-1
Bid Documents	
<i>(Forms listed below are to be returned with bid)</i>	
• Bid Form	BF-1 to BF-4
• Certified Copy of Resolution of Board of Directors	BF-5
• Bid Summary Sheets	BS-1 to BS-44
• Non-Collusive Bidding Certification, Offerer Disclosure of Prior Non-Responsibility Determinations, Combined Certification Form	Appendix 12-1A.1 to 12-1A.5
• Bid Bond	BB-1 to BB-2
• Affidavit of Workers Compensation	WC-1
• Iran Divestment Act Certification	ID-1
• D/M/WBE Utilization Goals	DMWBE-1 to DMWBE-2
• Federal DBE Commitment and GFE Bid Requirements	FDBE-1
• NYSDOT Sexual Harassment Prevention Certification for Construction	SHP-1
<i>(Forms listed below are to be returned within 7 days of Bid Opening)</i>	
• NYS Uniform Contracting Questionnaire	17 pages (minimum)
Agreement	AG-1 to AG-6
Construction Payment Bond	2 pages
Construction Performance Bond	2 pages
Appendix A – Additional State and Federal Conditions	Appendix 12-1.1 to 12-1.25
New York State Prevailing Rates – Special Note & Supplemental Information	As noted
Federal Davis Bacon Wages	As noted
Inclusion of Standard Specifications	SS-1
<b><u>Post Award Forms:</u></b>	
Change Order Form	1 page
Notice of Award (NOA)	2 pages
Notice to Proceed (NTP)	1 page
<b><u>Technical Specifications</u></b>	
Special Notes	As noted
Special Specifications	As noted

## **BID ADVERTISEMENT**

Notice is hereby given that the **City of Rome** will accept sealed bids for:

**Downtown Rome Wheels to Heels Streetscapes, Erie Boulevard, Rome NY**  
**PIN 2650.57**  
**RFB 2024-028**

The Owner is the **City of Rome** and the work site is/are located in the **City of Rome** The projects limits extend from: **Erie Boulevard between S. George St. and S. James St.**

The work includes providing all labor, materials, machinery, tools, equipment and other means of construction necessary and incidental to the completion of the work shown on the plans and described in these specifications including, but not necessarily limited to the following:

**Removal of the existing access road and installing pedestrian and bicycle facilities including sidewalks, a cycle track, a shared use path, and other amenities. The median island will be renovated and resized to include a new median wall, tree plantings, and mid-block crossing. Additional project elements include upgrading pedestrian crossings with new push buttons and pedestrian signals, new ADA curb ramps, pedestrian refuge islands, RRFB mid-block crossing, driveway delineations, improved signage and landscaping.**

This is a Federal Aid Project and NYSDOT Standard Specifications, officially finalized and adopted on **September 1, 2024** as posted on the New York State Department of Transportation's website must be followed by the successful bidder.

The DBE goal for this project is: **6%**  
**There are no M/WBE goals for this project.**

The EEO Employment goals for this project are: **2.1%** Minority Employment Goal  
**6.9%** Women Employment Goal

The use of the NYSDOT approved civil rights reporting software, Equitable Business Opportunities (EBO), is required. Access authorization to EBO can be found at <https://ebo.dot.ny.gov/>.

No residential or geographical restrictions will be in effect for this project. Applicable Federal requirements take precedence over State and local requirements unless state and local requirements are deemed to be more stringent.

Contract Documents, including Invitation to Bidders, Instructions to Bidders, Wage Rates, Bid Documents, Agreement, Special Notes, Specifications, Contract Drawings, and any Addenda, may be examined, at no expense, at the office of: **City Engineer** located **198 North Washington Street, Rome, NY 13440** between the hours of **9am** till **3pm** Monday through Friday. Contract Documents are also available at

- <http://www.romenewyork.com/treasurer-purchasing/>
- <https://www.bidnetdirect.com/new-york/city-of-rome>
- <https://www.nyscr.ny.gov/>

No questions or inquiries regarding this bid will be accepted within three (3) business days prior to the bid opening.

Contractors that obtain Contract Documents from a source other than the issuing office must notify the issuing office in order to be placed on the official Plan Holder List, to receive Addenda and any other Bid correspondence. Bids received from Contractors other than those on the official Plan Holders List will not be accepted. **To be placed on the official plan holders list please contact the Community and Economic Development Department at (315) 339-7643.**

Addenda will be emailed from the **City of Rome** to Bidders listed on the official Plan Holders List. An emailed response from the Bidder to the Addendum sent by **City of Rome** will act as proof that the Bidder received the Addendum. In addition to an emailed response, Bidders must acknowledge receipt of all Addenda by signing and dating each Addendum on page **BF-1** of the Bid Form and the Acknowledgement of Receipt of Addenda, page BF-1. Failure of any Bidder to receive any such Addendum or interpretation shall not relieve such Bidder from any obligation under this Bid submittal. All Addenda so issued shall become part of the Contract Documents.

Questions regarding the Contract Documents should be directed to **Christopher Cornwell, P.E.** through email at: [ccornwell@gpinet.com](mailto:ccornwell@gpinet.com). Bidders shall promptly notify Christopher Cornwell of any errors, omissions, conflicts or ambiguity within the Contract Documents within 5 days of bid opening.

All bids must include the completed Bid Form, Non-Collusive Bidding and Disbarment Certifications, and Lobbying Certifications. This is a **unit price** bid as described in the Instructions to Bidders. No bidder may withdraw his/her bid within forty-five (45) calendar days after the actual date of the opening thereof.

Each bid must be accompanied by security in an amount not less than five percent (5%) of the amount of the bid in the form and subject to the conditions provided in the Instructions to Bidders.

Bids to be considered must be received in a sealed envelope at **198 North Washington Street, Rome NY 13440** by **11:00 am**, local time, **on October 24, 2024** at which time they will be publicly opened and read aloud in the Rome City hall, 2<sup>nd</sup> Floor Council Chamber. Bids received after the above noted time will not be accepted. All sealed envelopes should be clearly labeled

**RFB #2024-028/D040238/PIN 2650.57**  
**Downtown Rome Wheels to Heels Streetscapes**

The Bidder to whom the Contract is awarded will be required to furnish Performance and Payment Bonds guaranteeing performance of work and prompt payment from an acceptable Surety Company for an amount not less than 100% of the accepted bid. The successful Bidder and all subcontractors must have an approved CCA-2 on file with NYSDOT prior to being awarded a contract. If the successful Bidder does not currently have a CCA-2 on file with NYSDOT, the Bidder may find the CCA-2 forms and instruction for completion online at <https://www.osc.state.ny.us/state-vendors/vendrep/vendor-responsibility-forms?redirect=legacy#Construction>.

The successful Bidder will be required to comply with all provisions of the Federal Government Equal Employment Opportunity clauses issued by the Secretary of Labor on May 2,1968 and published in the Federal Register (41 CFR Part 60-1, 33 F.2 7804). Successful bidders will be required to pay prevailing wage rates on this contract.

**The City of Rome** reserves the right to consider the bids for forty-five (45) days after receipt before awarding any Contract, and to waive any minor informalities in, and to reject, any and all bids. All bids are subject to final review and approval by the **City of Rome** before any award of contract may be made. Receipt of bids by the **City of Rome** shall not be construed as authority to bind the **City of Rome**.

The work will be substantially completed **150** calendar days from Notice to Proceed and completed and ready for final payment on **8/29/2025**.

The New York State Department of Transportation, in accordance with Title VI of the Civil Rights Act of 1964, 78 Stat. 252, 42 U.S.C 2000d to 2000d-4 and Title 49 Code of Federal Regulations, Department of Transportation, Subtitle A, Office of the Secretary, Part 21, Nondiscrimination in Federally-assisted programs of the Department of Transportation and Title 23 Code of Federal Regulations, Part 200, Title VI Program and Related Statutes, as amended, issued pursuant to such Act, hereby notifies all who respond to the related solicitation, request for proposal or invitation to bid that it will affirmatively insure that in any contract entered into pursuant to this advertisement, disadvantaged business enterprises will be afforded full opportunity to submit bids in response to this invitation and will not be discriminated against on the grounds of race, color, national origin, sex, age, disability/handicap and income status in consideration for an award.

It is the policy of the City of Rome to encourage the greatest possible participation of minority and women-owned business enterprises (MWBEs). All qualified MWBE suppliers, contractors, and/or businesses will be afforded equal opportunity without discrimination because of race, color, religion, national origin, sex, age, disability, or sexual preference. The City of Rome reserves the right to reject any or all proposals or to accept any proposals deemed to be in its best interest.

**Owners Contact**

Matthew Andrews  
Community and Economic Development  
198 North Washington Street  
Rome NY 13440  
315.339.7643  
[mandrews@romecitygov.com](mailto:mandrews@romecitygov.com)

**Engineer's Contact**

Christopher Cornwell  
Civil/Highway Dept Manager  
80 Wolf Road, Suite 600  
Albany NY 12205  
518.852.4269  
[ccornwell@gpinet.com](mailto:ccornwell@gpinet.com)

## INSTRUCTIONS TO BIDDERS

### PROJECT IDENTIFICATION:

- a) Project Title: Downtown Rome Wheels to Heels Streetscapes
- b) Owner: City of Rome
- c) Engineer: Greenman-Pedersen, Inc.

<u>Paragraph</u>	<u>INDEX</u>	<u>Page</u>
1. Defined Terms.....		2
2. Copies of Bidding Documents .....		2
3. Bidders Qualifications.....		2
4. Examination of Contract Documents and Site .....		2
5. Availability of Lands for Work, etc. ....		3
6. Interpretation and Addenda.....		3
7. Bid Security.....		3
8. Contract Times .....		4
9. Liquidated Damages.....		4
10. Substitute and “Or-Equal” Items .....		4
11. Subcontractors, Suppliers and Others .....		4
12. Bid Form .....		4
13. Submission of Bids.....		4
14. Modification and Withdrawal of Bids.....		5
15. Opening of Bids .....		5
16. Bids to Remain Subject to Acceptance .....		5
17. Award of Contract.....		5
18. Contract Security .....		5
19. Signing of Agreement.....		5
20. Prebid Conference.....		6
21. Lobbying Activities on Federal Aid Contracts .....		6
22. Sales and Use Taxes.....		6
23. Non-Collusive Bidding Procedures.....		6
24. Disadvantaged Business Enterprise Utilization Goals.....		6
25. Equal Employment Opportunity Participation Goals.....		6
26. Schedule for Bid and Award of Contract.....		6
27. Prevailing Wages .....		6
28. Federal Aid Contract .....		6
29. Delegation of Authority.....		6

## 1. Defined Terms

1.1. Certain additional terms used in these Instructions to Bidders have the meanings indicated below which are applicable to both the singular and plural thereof.

- Bidder – one who submits a bid directly to owner as distinct from sub-bidder, who submits a bid to a bidder.
- Issuing Office – the office from which the bidding documents are to be issued and where the bidding procedures are to be administered.
- Successful Bidder – the lowest responsible, responsive bidder to whom owner (on the basis of owners evaluation as hereinafter provided) makes an award.
- Agreement – The written contract between OWNER and CONTRACTOR covering the Work to be performed.
- Bid – The offer or proposal of the bidder submitted on the prescribed form setting forth the prices for the Work to be performed.
- Bidding Documents – The advertisement or invitation to Bid, instructions to bidders, the Bid form, and the proposed Contract Documents (including all Addenda issued prior to receipt of Bids)
- Contract Times – The number of days to the dates stated in the Agreement; to achieve substantial completion and to complete the Work so that it is ready for final payment as evidence by ENGINEER's written recommendation of final payment.
- CONTRACTOR – The person, firm or corporation with whom Owner has entered into the Agreement.
- Drawings – The drawings which show the scope, extent, and character of the Work to be furnished and performed by CONTRACTOR and which have been prepared or approved by ENGINEER and are referred to in the Contract Documents. Shop drawings are not Drawings as so defined.
- Effective Date of the Agreement – The date indicated in the Agreement on which it becomes effective, but if no such date is indicated it means the date on which the agreement is signed and delivered by the last of the two parties to sign and deliver.
- Engineer – The person, firm or corporation named as such in the Agreement.
- Notice of Award – The written notice by OWNER to the apparent successful bidder stating that upon compliance by the apparent successful bidder with the conditions present therein, within the time specified, OWNER will sign and deliver the Agreement.
- OWNER – The public body or authority, corporation, association, firm or person with whom CONTRACTOR has entered into the

Agreement and for whom the Work is to be provided.

- Underground Facilities – All pipelines, conduits, ducts, cables, wires, manholes, vaults, tanks, tunnels, or other such facilities or attachments, and any encasements containing such facilities which have been installed underground to furnish any of the following services or material: electricity, gases, steam, liquid petroleum products, telephone, cable television, or other communications, sewage and drainage removal, traffic or other control systems or water.
- Substantial completion - When the public (including vehicles and pedestrians) has full and unrestricted use and benefit of the facility both from an operational and safety standpoint.

## 2. Copies of Bidding Documents

2.1. Complete sets of the Bidding Documents in the number and for the deposit sum, if any, stated in the Advertisement or Notice to Bidders may be obtained from the Issuing Office. If the bidding documents are obtained from a source other than the issuing office, contractor must notify issuing office in order to be placed on the official plan holder's list, receive addenda and other bid correspondence. Bids received from contractors other than those on the official plan holder's list will not be accepted.

2.2. Complete sets of Bidding Documents must be used in preparing Bids; neither Owner nor Engineer assume any responsibility for errors or misinterpretations resulting from the use of incomplete sets of Bidding Document.

2.3. Owner and Engineer in making copies of Bidding Documents Available on the above terms do so only for the purpose of obtaining Bids for the Work and do not confer a license or grant for any other use.

## 3. Bidders Qualifications

All Bidders, including foreign and domestic corporations must be qualified and/or licensed to do business within the state where the project is located. The Owner reserves the right to make any investigation deemed necessary to determine bidder qualifications and responsibility. Bidder shall furnish to the Owner, upon request, all data pertinent thereto.

## 4. Examination of Contract Documents and Site

4.1. It is the responsibility of each bidder before submitting a Bid:

4.1.1. To examine thoroughly the Contract Documents and other related data identified in the

bidding documents (including “technical data” referred to below);

4.1.2. To visit the site to become familiar with and satisfy Bidder as to the general, local, and site conditions that may affect cost, progress, performance, or furnishing of the work;

4.1.3. To consider federal, state, and local laws and regulations that may affect cost, progress, performance, or furnishing of the Work;

4.1.4. To study and carefully correlate Bidders knowledge and observations with the Contract Documents and such other related data;

4.1.5. To promptly notify Engineer of all conflicts, errors, ambiguities or discrepancies which Bidder has discovered in or between the Contract Documents and such other related documents.

4.2. Information and data or indicated in the Contract Documents with respect to existing Underground Facilities at or contiguous to the site is based upon information and data furnished to Owner and Engineer by Owners of such Underground Facilities or others, and the Owner and Engineer do not assume responsibility for the accuracy or completeness thereof.

4.3. Before submitting a Bid each Bidder will be responsible to obtain such additional or supplementary examinations, investigations, explorations, tests, studies, and data concerning conditions (surface, subsurface, and Underground Facilities) at or contiguous to the site or otherwise, which may affect cost, progress, performance or furnishing of the Work or which relate to any aspect of the means, methods, techniques, sequences or procedures of construction to be employed by Bidder and safety precautions and programs incident thereto or performing and furnishing the Work in accordance with the time, price, and other terms and conditions of the Contract Documents.

4.4. On request, OWNER will provide each Bidder access to the site to conduct such examinations, investigations, explorations, tests, and studies as each Bidder deems necessary for submission of a Bid. Bidder must fill all holes and clean up and restore the site to its former conditions upon completion of such explorations, investigations, tests and studies.

4.5. The submission of a Bid will constitute an incontrovertible representation by Bidder that Bidder has complied with every requirement of this Article 5, that without exception of the Bid is premised upon performing and furnishing the Work required by the Contract Documents and applying the specific means, methods, techniques, sequences, or procedures for construction (if any) that may be shown or indicated or expressly required by the Contract Documents, the Bidder has given Engineer written notice of all conflicts, errors,

ambiguities and discrepancies that Bidder has discovered in the Contract Documents, and the Contract Documents are generally sufficient to indicate and convey understanding of all terms and conditions for performing and furnishing the Work.

## **5. Availability of Lands for Work, etc.**

The lands upon which the Work is to be performed, right-of-way and easements for access thereto and other lands designated for use by the Contractor in performing the Work are identified in the Contract Documents. All additional land and access thereto required for temporary construction facilities, construction equipment, or storage of materials and equipment to be incorporated in the Work are to be obtained and paid for by the CONTRACTOR. Easements for permanent structures or permanent changes in existing facilities are to be obtained and paid for by OWNER unless otherwise provided in the Contract Documents.

## **6. Interpretation and Addenda**

6.1. All questions about the meaning or intent of the Bidding documents are to be directed to Engineer through the Purchasing Agent. Interpretations or clarifications considered necessary by Engineer in response to such questions will be issued by Addenda mailed or delivered to all parties recorded by Purchasing Agent as having received the Bidding documents. Questions received less than ten days prior to the date for opening of the Bids may not be answered. Only questions answered by formal written Addenda will be binding. Oral and other interpretations or clarifications will be without legal effect.

6.2. Addenda may also be issued to modify the Bidding documents as deemed advisable by OWNER and ENGINEER.

## **7. Bid Security**

7.1. Each Bid must be accompanied by Bid security made payable to the OWNER in the amount of five percent (5%) of Bidders maximum Bid price and in the form of a certified or bank check or a Bid Bond (on form attached, if a form is prescribed) issued by a surety.

7.2. The Bid security of Successful Bidder will be retained until such Bidder has executed the Agreement, furnished the required contract security and met the other conditions of the Notice of Award, whereupon the Bid security will be returned. If the Bidder fails to execute and deliver the Agreement and furnish the required contract security within fifteen days after Notice of Award, OWNER may annul the Notice of Award and the Bid security of that Bidder will be forfeited. The Bid security of other Bidders whom OWNER believes to have a reasonable chance of



receiving the award may be retained by the OWNER until the earlier of the seventh day after the Effective Date of the Agreement or the forty-fifth day after the Bid opening, whereupon Bid security furnished by such Bidders will be returned. Bid security with Bids which are not competitive will be returned within seven days after the bid opening.

## **8. Contract Times**

The number of days within which, or the dates by which, the Work is to be substantially completed and also completed and ready for final payment.

## **9. Liquidated Damages**

Provisions for Liquidated Damages, if any, are set forth in the Agreement.

## **10. Substitute and "Or-Equal" Items**

The Contract, if awarded, will be on the basis of materials and equipment described in the Drawings or specified in the Specifications without consideration of possible substitute or "or-equal" items. Whenever it is indicated in the Drawings or specified in the Specifications that a substitute or "or-equal" item of material or equipment may be furnished or used by Contractor if acceptable to Engineer, application for such acceptance will not be considered by Engineer until after the Effective Date of the Agreement.

## **11. Subcontractors, Suppliers and Others**

11.1. The identity of certain Subcontractors, Suppliers and other persons and organizations (including those who are to furnish the principal items of material and equipment) to be submitted to the OWNER in advance of a specified date prior to the Effective Date of the Agreement, apparent Successful Bidder, and any other Bidder so requested, shall within five days of Notice of Award submit to OWNER a list of all such Subcontractors, Suppliers and other persons and organizations proposed for those portions of the Work for which such identification is required.

An OWNER or ENGINEER who after due investigation reasonably believes that a Subcontractor, Supplier or other person or organization is suspended, debarred or has otherwise been declared ineligible to perform this contract, may request that a Successful Bidder submit an acceptable substitute Subcontractor, Supplier, person or organization.

If apparent Successful Bidder declines to make any such substitution, the OWNER may award the contract to the next lowest Bidder that proposes to use acceptable Subcontractors, Suppliers, other persons and organizations.

11.2. In contracts where the Contract Price is on the basis of Cost-of-the-Work Plus a Fee, apparent Successful Bidder, prior to the Notice of Award, shall identify in writing to the OWNER those portions of the Work that such Bidder proposes to subcontract and after the Notice of Award may only subcontract other portions of the Work with OWNER's written consent.

11.3. No CONTRACTOR shall be required to employ any Subcontractor, Supplier, other person or organization against whom the CONTRACTOR has a reasonable objection.

## **12. Bid Form**

12.1. The Bid Form and the Bid Summary Form (where applicable) are included with the Bidding documents; additional copies may be obtained from Engineer (or issuing office).

12.2. All blanks on the Bid Form must be completed by printing in black ink or by typewriter.

12.3. Bids by corporations must be executed in the corporate name by the president or vice president (or corporate officer accompanied by evidence of authority to sign) and the corporate seal must be affixed and attested by the secretary or an assistant secretary. The corporate address and state of incorporation must be shown below the signature.

12.4. Bids by partnerships must be executed in the partnership name and signed by a partner, whose title must appear under the signature and the official address of the partnership must be shown below the signature.

12.5. All names must be typed or printed in black ink below the signature.

12.6. The Bid shall contain acknowledgement of receipt of all Addenda (the numbers of which must be filled in on the Bid Form).

12.7. The address and telephone number for communications regarding the Bid must be shown.

12.8. All documents set forth in the Bidders Checklist must be submitted with bid.

## **13. Submission of Bids**

Bids shall be submitted at the time and place indicated in the Advertisement or Notice to Bidders and shall be enclosed in a sealed envelope, marked with the project title and name an address of Bidder and accompanied by the Bid security and other required documents (see bidders checklist). If the Bid is sent through the mail or other delivery system, the sealed envelope shall be enclosed in a separate envelope with the notation "BID ENCLOSED" on the face of it.

#### **14. Modification and Withdrawal of Bids**

14.1. Bids may be modified or withdrawn by an appropriate document duly executed (in the manner that a Bid must be executed) and delivered to the place where Bids are submitted at any time prior to the opening of Bids.

14.2. Where a unilateral error or mistake is discovered in a Bid, such Bid may be withdrawn after showing of the following: (1) the mistake is known or made known to the OWNER and ENGINEER prior to the awarding of the contract or within three days after opening of the Bid, whichever period is shorter; and (2) the price Bid was based on an error of such magnitude that enforcement would be unconscionable; and (3) the Bid was submitted in good faith and the Bidder submits credible evidence that the mistake was a clerical error as opposed to a judgment error; and (4) the error in the Bid is actually due to an unintentional and substantial arithmetic error or an unintentional omission of a substantial quantity of work, labor, material, goods or services made directly in the compilation of the Bid, which unintentional arithmetic error or unintentional omission can be clearly shown by objective evidence drawn by inspection of the original work papers, documents or materials used in the preparation of the Bid; and (5) it is possible to place the OWNER in status quo ante.

#### **15. Opening of Bids**

Bids will be opened and (unless obviously non-responsive) read aloud publicly at the place where bids are to be submitted. An abstract of the amounts of the base Bids and major alternates (if any) may be made available to Bidders after the opening of the Bids.

#### **16. Bids to Remain Subject to Acceptance**

All Bids will remain subject to acceptance for forty-five (45) days after the day of the Bid opening, but OWNER may, in its sole discretion, release any Bid and return the Bid security prior to that date.

#### **17. Award of Contract**

17.1. To the fullest extent permitted by law OWNER reserves the right to reject any or all Bids, including without limitation the rights to reject any or all nonconforming, non-responsive, unbalanced, or conditional Bids and to reject the Bid of any Bidder if OWNER believes that it would not be in the best interest of the project to make an award to that Bidder, whether because the Bid is not responsible or the Bidder is unqualified or of doubtful financial ability or fails to meet any other pertinent standard or criteria established by OWNER. OWNER also reserves the right to waive all informalities not involving price, time, or changes in the Work and to negotiate, to the extent permitted by law, contract times with the Successful Bidder.

17.2. Discrepancies between words and figures will be resolved in favor of the words. Discrepancies between the multiplication of units of Work and unit prices will be resolved in favor of the unit prices. Discrepancies between the indicated sum of any column of figures and the correct sum thereof will be resolved in favor of the correct sum. Discrepancies between words and figures will be resolved in favor of the words.

17.3. In evaluating Bids, OWNER will consider the qualifications of Bidders, whether or not the Bids comply with the prescribed requirements, and such alternates, lump sum price and other data, as may be requested in the Bid form or prior to Notice of Award.

17.4. OWNER may consider the operating costs, maintenance requirements, performance data and guarantees of major item of materials and equipment proposed for incorporation in the Work when such data is required to be submitted prior to Notice of Award.

17.5. OWNER may conduct such investigations as OWNER deems necessary to assist in the evaluation of any Bid and to establish the responsibility, qualifications, and financial ability of Bidders, to perform and furnish the Work in accordance with the Contract Documents to OWNER'S satisfaction within the prescribed time.

17.6. If the contract is to be awarded, it will be awarded to the lowest responsible Bidder whose evaluation by OWNER indicates to OWNER that the award will be in the best interest of the project.

17.7. If the contract is to be awarded, OWNER will give successful Bidder a Notice of Award within forty-five (45) days after the day of the Bid opening.

#### **18. Contract Security**

When successful Bidder delivers the executed Agreement to OWNER, it must be accompanied by the required performance and payment Bond.

#### **19. Signing of Agreement**

When OWNER gives Notice of Award to the Successful Bidder, it will be accompanied by the required number of unsigned counterparts of the Agreement Within fifteen days thereafter CONTRACTOR shall sign and deliver the required number of counterparts of the Agreements to OWNER with the required bonds. Within ten days thereafter OWNER shall deliver one fully signed counterpart to CONTRACTOR.

**20. Prebid Conference**

A prebid conference may be held as outlined in the Notice to Bidders. If held, representatives of the OWNER and ENGINEER will be present to discuss the Project. Bidders are encouraged to attend and participate in the conference. ENGINEER will transmit to all prospective Bidders of record such Addenda as ENGINEER considers necessary in response to questions arising at the conference. Oral statements may not be relied upon and will not be binding or legally effective.

**21. Lobbying Activities on Federal Aid Contracts**

Each Bidder is required to comply with the provisions contained in the Requirements Regarding Lobbying Activities on Federal Aid Contracts and shall submit the Disclosure of Lobbying Activities with the Bid.

**22. Sales and Use Taxes**

OWNER is exempt from New York State Sales and Use Tax on materials and equipment to be incorporated into work. Said taxes should not be included in Contract Price.

**23. Non-Collusive Bidding Procedures**

Each Bidder is required to comply with the requirement regarding non-collusive bidding procedures and shall submit the appropriate Non-Collusive Bidding Certification and Non-Collusive Bidding Certification Bidder Information with the Bid. Knowledge of bid collusions or other questionable contract related practices shall be reported per the instructions contained in Reporting Violations of the Non-Collusive Bidding Procedures, Misconduct, or other Prohibited Contract Activities.

**24. Disadvantaged Business Enterprise Utilization Goals**

The provisions for Disadvantaged Business Enterprise Utilization Goals are set forth in Appendix A. Each Bidder must submit the Disadvantaged Business Enterprise Utilization Goals form with its Bid.

**25. Equal Employment Opportunity Participation Goals**

The provisions for Equal Employment Opportunity Participation Goals are set forth in Appendix A.

**26. Schedule for Bid and Award of Contract**

A schedule of the major events required for the Bid and Award is shown below:

Notice of Award	No later than 45 days following Bid Opening
Signed Documents returned by Contractor	No later than 15 days following Notice of Award
Signed Documents returned by the Owner with Notice to Proceed	No later than 10 days following Signed Documents returned by Contractor
Submittal of Bonds and Insurance	No later than 15 days following Notice of Award

**27. Prevailing Wages**

This is a public works project and the higher of Davis-Bacon wages and prevailing wages as determined by the New York State Department of Labor must be paid.

**28. Federal Aid Contract**

This is a federally-aided contract subject to the approval of New York State Department of Transportation (NYSDOT).

The low bidder will be required to complete a New York State Uniform Contracting Questionnaire. The questionnaire must be reviewed and approved by NYSDOT before the Owner may award the Contract.

**29. Delegation of Authority**

Where reference is made to New York State, Commissioner of Transportation, State Department of Transportation Officials and Employees, etc., either in these specifications or the NYSDOT *Standard Specification, Construction and Materials* it shall mean the appropriate City, Bureau or Official.

The City or its authorized representative shall make all final interpretations of any questions or irregularities arising out of these specifications and the NYSDOT *Standard Specification, Construction and Materials* used on this project.

Under subsequent sections of this document the term "OWNER" shall mean the City and being the governmental unit whose name is given on the Contract Document cover.

**D040238  
PIN 2650.57**

**SUPPLEMENTAL INFORMATION AVAILABLE TO BIDDERS**

The following information is available at the Office of the Owner and Engineer, as identified in the advertisement for bids, for inspection and review prior to the letting date. It is mutually understood that this data is independent information the Engineer and/or Owner has assembled and the bidder shall assume the risk of its accuracy and that the information is not prepared or used as part of the contract plans and that Article 7 of the Agreement will apply. This information is not to be considered as a substitution or revision of that section of the standard specifications defining specifications and contract agreements.

By his/her signature on this proposal the bidder certifies that he/she has made himself aware of this availability, for his/her inspection and review prior to the letting date, of the information indicated below:

<b>Available</b>	<b>Not Available</b>	<b>Information</b>
	X	Utility Estimate Sheets with Names of Utility Officials
X		Right of Way Plan
	X	Earthwork Cross Sections
	X	Earthwork Sheets
	X	Drainage Estimate Sheets
	X	Sign Face Layouts
	X	Logs of Subsurface Exploration
	X	Tabulated Results of Probing
	X	Tabulated Depth to Bed Rock
	X	Logs Showing Laboratory Description of Soil Samples
	X	Laboratory Test Data from Soil Samples
	X	Rock Outcrop Maps
	X	Granular Materials Resources Survey Reports
	X	Terrain Reconnaissance Reports
	X	Subsurface Data Obtained from Sources Outside the Department
	X	Granular Material Sources Report
X		Record Plans
	X	SPDES Report/SWPPP
X		Special Reports or Other Information (Identified Below) <ul style="list-style-type: none"> <li>• Final Design Report</li> </ul>

If you choose not to bid on this project, please consider returning this form to the following address:

Matthew Andrews  
Deputy Director of Community and Economic Development  
City of Rome  
198 North Washington St, Rome NY 13440

**NON-BIDDERS RESPONSE**

<b>VENDOR NAME:</b>	
---------------------	--

For purposes of striving to improve our bidding process, as well as to facilitate your firm's response to our future invitations to bid, we are interested in ascertaining reasons why you chose not to bid on this particular project. In this regard, please provide a short explanation/reason for your choice not to bid in the space provided below:

---

---

---

---

---

## **BIDDER'S CHECKLIST**

In order to submit a complete bid, Bidders must submit the following documents:

- \_\_\_\_\_ Bid Form (BF-1 to BF-4)
- \_\_\_\_\_ Certified Copy of Resolution of Board of Directors (For Corporations) (BF-5)
- \_\_\_\_\_ Bid Summary Form(s) (BS-1 to BS-44)
- \_\_\_\_\_ Non-Collusive Bidding Certification, Offerer Disclosure of Prior Non-responsibility Determinations, and Combined Certification Form (Appendix 12-1A)
- \_\_\_\_\_ NYSDOT Sexual Harassment Prevention Certification (SHP-1)
- \_\_\_\_\_ Bid Bond or Certified Bank Check (BB-1 to BB-2)
- \_\_\_\_\_ Affidavit of Worker's Compensation (WC-1)
- \_\_\_\_\_ Certification of Compliance Iran Divestment Act (ID-1)
- \_\_\_\_\_ D/M/WBE Utilization Goals (DMWBE-1)
- \_\_\_\_\_ DBE Commitments Form (FDBE-1)
- \_\_\_\_\_ Proof of Ability to do Work in NYS or Covenant to Obtain (obtained from NY Dept of State)

**Also the following forms are due from the apparent responsible low bidder no later than 5 days after bid opening:**

- \_\_\_\_\_ NYS Uniform Contracting Questionnaire with attachments (17 pages minimum)
- \_\_\_\_\_ The Contractor shall submit a complete DBE utilization package in EBO.

***BIDDERS SHALL SUBMIT ALL DOCUMENTS PRESENTED IN THIS PROJECT MANUAL ON SINGLE-SIDED SHEETS IN THE EXACT ORDER SHOWN. NO SUBSTITUTION OF FORMS WILL BE ALLOWED. ENTRIES MAY BE TYPED OR LEGIBLY HANDWRITTEN EXCEPT AS SPECIFICALLY NOTED.***

BID FORM

PROJECT IDENTIFICATION:                    PIN 2650.57  
                                                          Downtown Rome Wheels to Heels Streetscapes  
                                                          City of Rome, Oneida County, New York

CONTRACT IDENTIFICATION:                D04238

THIS BID IS SUBMITTED TO:                City of Rome

1. The undersigned BIDDER proposes and agrees, if this bid is accepted, to enter into an agreement with OWNER in the form included in the Contract Documents to perform and furnish all work as specified or indicated in the Contract Documents for the Bid Price and Bid Times indicated in this Bid and in accordance with the other terms and conditions of the Contract Documents
  
2. Bidder accepts all the terms and conditions of the Advertisement or Notice to Bidders and Instructions to Bidders, including without limitation those dealing with the disposition of Bid security. This Bid will remain subject to acceptance for forty-five (45) days after the Bid opening. Bidder will sign and deliver the required number of counterparts of the Agreement with the Bonds and other documents required by the Bidding Requirements within fifteen (15) days after the date of OWNER’s Notice of Award
  
3. In submitting this Bid, BIDDER represents as more fully set forth in the Agreement, that:
  - a. BIDDER has examined and carefully studied the Bidding Documents and the following Addenda receipt of all which is hereby acknowledged: (List Addenda by Addendum Number and Date)  
  
\_\_\_\_\_  
\_\_\_\_\_  
\_\_\_\_\_  
\_\_\_\_\_  
\_\_\_\_\_
  
  - b. BIDDER has visited the site and become familiar with and is satisfied as to the general, local, and site conditions that may affect cost, progress, performance, and furnishing of the work.
  
  - c. BIDDER is familiar with and is satisfied as to all federal, state, and local Laws and Regulations that may affect cost, progress, performance, and furnishing of work.

- d. BIDDER is aware of the general nature of work to be performed by OWNER and others at the site that relates to work for which this Bid is submitted as indicated in the Contract Documents
- e. BIDDER has correlated the information known to BIDDER, information and observations obtained from visits to the site, reports and drawings identified in the Contract Documents and all additional examinations, investigations, explorations, test, studies, and data with the Contract Documents
- f. BIDDER has given ENGINEER written notice of all conflicts, errors, ambiguities or discrepancies that BIDDER has discovered in the Contract Documents and the written resolution thereof by ENGINEER is acceptable to BIDDER, and the Contract Documents are generally sufficient to indicate and convey understanding of all terms and conditions for performing and furnishing the Work for which this Bid is submitted.
- g. This bid is genuine and not made in the interest of or on behalf of any undisclosed person, firm, or corporation and is not submitted in conformity with any agreement or rules of any group, association, organization, or corporation; BIDDER has not directly or indirectly induced or solicited any other BIDDER to submit a false or sham Bid; BIDDER has not solicited or induced any person, firm or corporation to refrain from bidding; and BIDDER has not sought by collusion to obtain for itself any advantage over any other BIDDER or over OWNER.

4. Bidder will complete the Work in accordance with the Contract Documents for the following price:

TOTAL BID FOR ALL UNIT PRICES (Base Bid + Alt ~~X~~, 2, 3, AND 4)

\_\_\_\_\_ (\$ \_\_\_\_\_ )  
 (use words) (figures)

~~**ALTERNATIVE 1 – PARKING LOT A**~~

NIC

\_\_\_\_\_ (\$ \_\_\_\_\_ )  
 (use words) (figures)

**ALTERNATIVE 2 – FLEXIPAVE BUFFER TREATMENT**

\_\_\_\_\_ (\$ \_\_\_\_\_ )  
 (use words) (figures)



**ALTERNATIVE 3 – FLEXIPAVE MEDIAN TREATMENT**

\_\_\_\_\_ (\$ \_\_\_\_\_ )  
(use words) (figures)

**ALTERNATIVE 4 – DECORATIVE SINGLE SLOPE CONCRETE MEDIAN BARRIER**

\_\_\_\_\_ (\$ \_\_\_\_\_ )  
(use words) (figures)

BIDDER acknowledges that quantities are not guaranteed and final payment will be based on actual quantities determined as provided in the Contract Documents.

- 5. BIDDER agrees that the Work will be substantially completed and ready for final payment before the dates or within the number of calendar days indicated in the Agreement.

BIDDER accepts the provisions of the Agreement as to liquidated damages in the event of failure to complete the Work within the times specified in the Agreement.

- 6. The following documents are attached to and made a condition of this Bid:
  - a. All documents set forth in the Bidders Checklist.
- 7. Communications concerning this Bid shall be addressed in writing to:

City of Rome  
Office of Community and Economic Development  
198 North Washington Street, Rome, NY 13440

- 8. Terms used in this Bid will have the meanings indicated in the Instructions.

SUBMITTED on \_\_\_\_\_ 2024.

CONTRACTOR \_\_\_\_\_  
(Signature of Authorized Representative)

\_\_\_\_\_  
(Print Name)

\_\_\_\_\_  
(Title)

**BIDDER INFORMATION SHEET**

NAME OF BIDDER: \* \_\_\_\_\_

ADDRESS: \_\_\_\_\_

PHONE NUMBER: \_\_\_\_\_

TYPE OF ENTITY: CORPORATION \_\_\_\_ PARTNERSHIP \_\_\_\_ INDIVIDUAL \_\_\_\_

IF A NON-PUBLICLY OWNED CORPORATION:

NAME OF CORPORATION: \_\_\_\_\_

LIST OF PRINCIPAL STOCKHOLDERS (HOLDING OVER 5% OF OUTSTANDING SHARES):

\_\_\_\_\_  
\_\_\_\_\_

LIST OF OFFICERS: \_\_\_\_\_

\_\_\_\_\_

LIST OF DIRECTORS: \_\_\_\_\_

\_\_\_\_\_

DATE OF ORGANIZATION: \_\_\_\_\_

IF A PARTNERSHIP:

PARTNERS: \_\_\_\_\_

\_\_\_\_\_

NAME OF PARTNERSHIP: \_\_\_\_\_

DATE OF ORGANIZATION: \_\_\_\_\_

\* IF THE BUSINESS IS CONDUCTED UNDER AN ASSUMED NAME, A COPY OF THE CERTIFICATE REQUIRED TO BE FILED UNDER THE NEW YORK GENERAL BUSINESS LAW MUST BE ATTACHED.



**DOWNTOWN ROME WHEELS TO HEELS STREETSCAPES  
CITY OF ROME, ONEIDA COUNTY  
PIN 2650.57 / D040238**

**BASE BID**

ITEM NUMBER	ESTIMATED QUANTITY	ITEM DESCRIPTION WITH UNIT BID PRICE WRITTEN IN WORDS	UNIT BID PRICE		AMOUNT BID	
			DOLLARS	CENTS	DOLLARS	CENTS
203.02	2,859	UNCLASSIFIED EXCAVATION AND DISPOSAL  PER CUBIC YARD				
203.03	63	EMBANKMENT IN PLACE  PER CUBIC YARD				
203.07	98	SELECT GRANULAR FILL  PER CUBIC YARD				
206.0201	214	TRENCH AND CULVERT EXCAVATION  PER CUBIC YARD				
206.03	1,441	CONDUIT EXCAVATION AND BACKFILL INCLUDING SURFACE RESTORATION  PER LINEAR FOOT				

**DOWNTOWN ROME WHEELS TO HEELS STREETSCAPES  
CITY OF ROME, ONEIDA COUNTY  
PIN 2650.57 / D040238**

**BASE BID**

BROUGHT FORWARD \_\_\_\_\_

ITEM NUMBER	ESTIMATED QUANTITY	ITEM DESCRIPTION WITH UNIT BID PRICE WRITTEN IN WORDS	UNIT BID PRICE		AMOUNT BID	
			DOLLARS	CENTS	DOLLARS	CENTS
206.05	47	TEST PIT EXCAVATION  PER EACH				
304.12	1,040	SUBBASE COURSE, TYPE 2  PER CUBIC YARD				
404.0189	29	TRUING & LEVELING F9, ASPHALT, 80 SERIES COMPACTION  PER TON				
404.0982	114	9.5 F2 TOP COURSE ASPHALT, 80 SERIES COMPACTION  PER TON				
407.0103	81	TACK COAT STRAIGHT  PER GALLON				

**DOWNTOWN ROME WHEELS TO HEELS STREETSCAPES  
CITY OF ROME, ONEIDA COUNTY  
PIN 2650.57 / D040238**

**BASE BID**

BROUGHT FORWARD \_\_\_\_\_

ITEM NUMBER	ESTIMATED QUANTITY	ITEM DESCRIPTION WITH UNIT BID PRICE WRITTEN IN WORDS	UNIT BID PRICE		AMOUNT BID	
			DOLLARS	CENTS	DOLLARS	CENTS
418.7603	877	ASPHALT PAVEMENT JOINT ADHESIVE  PER LINEAR FOOT				
420.98010104	7,220	POROUS PAVING SURFACE PRODUCT, TYPE 01  PER SQUARE FOOT				
490.30	628	MISCELLANEOUS COLD MILLING OF BITUMINOUS CONCRETE  PER SQUARE YARD				
552.17	1,556	SHIELDS AND SHORING  PER SQUARE FOOT				
559.91100010	132	ANTI-GRAFFITI PROTECTIVE COATING  PER SQUARE FOOT				

**DOWNTOWN ROME WHEELS TO HEELS STREETSCAPES  
CITY OF ROME, ONEIDA COUNTY  
PIN 2650.57 / D040238**

**BASE BID**

BROUGHT FORWARD \_\_\_\_\_

ITEM NUMBER	ESTIMATED QUANTITY	ITEM DESCRIPTION WITH UNIT BID PRICE WRITTEN IN WORDS	UNIT BID PRICE		AMOUNT BID	
			DOLLARS	CENTS	DOLLARS	CENTS
560.12010010	158	SEAT WALL   PER LINEAR FOOT				
601.04030011	1,079	METHYL METHACRYLATE COLOR SURFACE TREATMENT FOR PAVEMENTS (MMA-CST) - GREEN FOR BICYCLE FACILITES   PER SQUARE FOOT				
603.77	2	CONCRETE COLLARS   PER EACH				
603.9815	225	SMOOTH INTERIOR CORRUGATED POLYETHYLENE CULVERT AND STORM DRAIN 15" DIAMETER   PER LINEAR FOOT				
604.070201	1	ALTERING DRAINAGE STRUCTURES, LEACHING BASINS AND MANHOLES   PER EACH				

**DOWNTOWN ROME WHEELS TO HEELS STREETSCAPES  
CITY OF ROME, ONEIDA COUNTY  
PIN 2650.57 / D040238**

**BASE BID**

BROUGHT FORWARD \_\_\_\_\_

ITEM NUMBER	ESTIMATED QUANTITY	ITEM DESCRIPTION WITH UNIT BID PRICE WRITTEN IN WORDS	UNIT BID PRICE		AMOUNT BID	
			DOLLARS	CENTS	DOLLARS	CENTS
604.070202	1	ALTERING DRAINAGE STRUCTURES, LEACHING BASINS AND MANHOLES  PER EACH				
604.070203	1	ALTERING DRAINAGE STRUCTURES, LEACHING BASINS AND MANHOLES  PER EACH				
604.070204	1	ALTERING DRAINAGE STRUCTURES, LEACHING BASINS AND MANHOLES  PER EACH				
604.070205	1	ALTERING DRAINAGE STRUCTURES, LEACHING BASINS AND MANHOLES  PER EACH				
604.070206	1	ALTERING DRAINAGE STRUCTURES, LEACHING BASINS AND MANHOLES  PER EACH				



**DOWNTOWN ROME WHEELS TO HEELS STREETSCAPES  
CITY OF ROME, ONEIDA COUNTY  
PIN 2650.57 / D040238**

**BASE BID**

BROUGHT FORWARD \_\_\_\_\_

ITEM NUMBER	ESTIMATED QUANTITY	ITEM DESCRIPTION WITH UNIT BID PRICE WRITTEN IN WORDS	UNIT BID PRICE		AMOUNT BID	
			DOLLARS	CENTS	DOLLARS	CENTS
604.070207	1	ALTERING DRAINAGE STRUCTURES, LEACHING BASINS AND MANHOLES  PER EACH				
604.070208	1	ALTERING DRAINAGE STRUCTURES, LEACHING BASINS AND MANHOLES  PER EACH				
604.070209	1	ALTERING DRAINAGE STRUCTURES, LEACHING BASINS AND MANHOLES  PER EACH				
604.070210	1	ALTERING DRAINAGE STRUCTURES, LEACHING BASINS AND MANHOLES  PER EACH				
604.070211	1	ALTERING DRAINAGE STRUCTURES, LEACHING BASINS AND MANHOLES  PER EACH				

**DOWNTOWN ROME WHEELS TO HEELS STREETSCAPES  
CITY OF ROME, ONEIDA COUNTY  
PIN 2650.57 / D040238**

**BASE BID**

BROUGHT FORWARD \_\_\_\_\_

ITEM NUMBER	ESTIMATED QUANTITY	ITEM DESCRIPTION WITH UNIT BID PRICE WRITTEN IN WORDS	UNIT BID PRICE		AMOUNT BID	
			DOLLARS	CENTS	DOLLARS	CENTS
604.070212	1	ALTERING DRAINAGE STRUCTURES, LEACHING BASINS AND MANHOLES  PER EACH				
604.070213	1	ALTERING DRAINAGE STRUCTURES, LEACHING BASINS AND MANHOLES  PER EACH				
604.070214	1	ALTERING DRAINAGE STRUCTURES, LEACHING BASINS AND MANHOLES  PER EACH				
604.070215	1	ALTERING DRAINAGE STRUCTURES, LEACHING BASINS AND MANHOLES  PER EACH				
604.070216	1	ALTERING DRAINAGE STRUCTURES, LEACHING BASINS AND MANHOLES  PER EACH				

**DOWNTOWN ROME WHEELS TO HEELS STREETSCAPES  
CITY OF ROME, ONEIDA COUNTY  
PIN 2650.57 / D040238**

**BASE BID**

BROUGHT FORWARD \_\_\_\_\_

ITEM NUMBER	ESTIMATED QUANTITY	ITEM DESCRIPTION WITH UNIT BID PRICE WRITTEN IN WORDS	UNIT BID PRICE		AMOUNT BID	
			DOLLARS	CENTS	DOLLARS	CENTS
604.070217	1	ALTERING DRAINAGE STRUCTURES, LEACHING BASINS AND MANHOLES  PER EACH				
604.070218	1	ALTERING DRAINAGE STRUCTURES, LEACHING BASINS AND MANHOLES  PER EACH				
604.070219	1	ALTERING DRAINAGE STRUCTURES, LEACHING BASINS AND MANHOLES  PER EACH				
604.070220	1	ALTERING DRAINAGE STRUCTURES, LEACHING BASINS AND MANHOLES  PER EACH				
604.301772	31	RECTANGULAR DRAINAGE STRUCTURE TYPE Q FOR CAST IRON F2 FRAME  PER LINEAR FOOT				

**DOWNTOWN ROME WHEELS TO HEELS STREETSCAPES  
CITY OF ROME, ONEIDA COUNTY  
PIN 2650.57 / D040238**

**BASE BID**

BROUGHT FORWARD \_\_\_\_\_

ITEM NUMBER	ESTIMATED QUANTITY	ITEM DESCRIPTION WITH UNIT BID PRICE WRITTEN IN WORDS	UNIT BID PRICE		AMOUNT BID	
			DOLLARS	CENTS	DOLLARS	CENTS
608.0101	296	CONCRETE SIDEWALKS AND DRIVEWAYS  PER CUBIC YARD				
608.01020005	191	COLORED AND IMPRINTED PORTLAND CEMENT CONCRETE SIDEWALK  PER CUBIC YARD				
608.020102	145	ASPHALT SIDEWALKS, DRIVEWAYS, AND BICYCLE PATHS  PER TON				
608.21000003	18	CAST IRON EMBEDDED DETECTABLE WARNING UNITS  PER SQUARE YARD				
609.0212	3,143	STONE CURB NEAR VERTICLE FACE (NVF)  PER LINEAR FOOT				

**DOWNTOWN ROME WHEELS TO HEELS STREETSCAPES  
CITY OF ROME, ONEIDA COUNTY  
PIN 2650.57 / D040238**

**BASE BID**

BROUGHT FORWARD \_\_\_\_\_

ITEM NUMBER	ESTIMATED QUANTITY	ITEM DESCRIPTION WITH UNIT BID PRICE WRITTEN IN WORDS	UNIT BID PRICE		AMOUNT BID	
			DOLLARS	CENTS	DOLLARS	CENTS
609.0217	383	STONE CURB TRAVERSABLE (TR)  PER LINEAR FOOT				
609.15	1,347	RESETTING EXISTING CURB  PER LINEAR FOOT				
610.1404	396	TOPSOIL - SPECIAL PLANTING MIX  PER CUBIC YARD				
610.1605	172	TURF ESTABLISHMENT - PERFORMANCE  PER SQUARE YARD				
610.19	40	WATERING VEGETATION  PER 1,000 GALLON (MGAL)				

**DOWNTOWN ROME WHEELS TO HEELS STREETSCAPES  
CITY OF ROME, ONEIDA COUNTY  
PIN 2650.57 / D040238**

**BASE BID**

BROUGHT FORWARD \_\_\_\_\_

ITEM NUMBER	ESTIMATED QUANTITY	ITEM DESCRIPTION WITH UNIT BID PRICE WRITTEN IN WORDS	UNIT BID PRICE		AMOUNT BID	
			DOLLARS	CENTS	DOLLARS	CENTS
611.0171	45	PLANTING - MAJOR DECIDUOUS TREES - 3 INCH CALIPER BALL & BURLAP, FIELD POTTED OR FIELD BOXED   PER EACH				
611.0711	61	PLANTING - HERBACEOUS PLANTS - AS SPECIFIED CONTAINER GROWN   PER EACH				
611.17	48	PORTABLE DRIP IRRIGATION SYSTEM   PER EACH				
611.19010024	45	POST PLANTING CARE WITH REPLACEMENT - MAJOR DECIDUOUS TREES   PER EACH				
611.19070024	61	POST PLANTING CARE WITH REPLACEMENT - HERBACEOUS PLANTS   PER EACH				

**DOWNTOWN ROME WHEELS TO HEELS STREETSCAPES  
CITY OF ROME, ONEIDA COUNTY  
PIN 2650.57 / D040238**

**BASE BID**

BROUGHT FORWARD \_\_\_\_\_

ITEM NUMBER	ESTIMATED QUANTITY	ITEM DESCRIPTION WITH UNIT BID PRICE WRITTEN IN WORDS	UNIT BID PRICE		AMOUNT BID	
			DOLLARS	CENTS	DOLLARS	CENTS
614.060204	8	TREE REMOVAL OVER 6 INCHES TO 12 INCHES DIAMETER BREAST HEIGHT - STUMPS GRUBBED  PER EACH				
615.08010005	5	BENCH, TYPE 01  PER EACH				
619.01	1	BASIC WORK ZONE TRAFFIC CONTROL  PER LUMP SUM				
619.110513	3	(PVMS) STANDARD SIZE - FULL MATRIX (LED) NO OPTIONALEQUIPMENT SPECIFIED, CELLULAR COMMUNICATIONS  PER EACH				
619.1611	27	MAINTAIN TRAFFIC SIGNAL EQUIPMENT (REQUIREMENT A)  PER INTERSECTION MONTH				

**DOWNTOWN ROME WHEELS TO HEELS STREETSCAPES  
CITY OF ROME, ONEIDA COUNTY  
PIN 2650.57 / D040238**

**BASE BID**

BROUGHT FORWARD \_\_\_\_\_

ITEM NUMBER	ESTIMATED QUANTITY	ITEM DESCRIPTION WITH UNIT BID PRICE WRITTEN IN WORDS	UNIT BID PRICE		AMOUNT BID	
			DOLLARS	CENTS	DOLLARS	CENTS
625.01	1	SURVEY OPERATIONS  PER LUMP SUM				
627.50140008	921	CUTTING PAVEMENT  PER LINEAR FOOT				
635.0103	3,743	CLEANING AND PREPARATION OF PAVEMENT SURFACES - LINES  PER LINEAR FOOT				
635.0303	12	CLEANING AND PREPARATION OF PAVEMENT SURFACES - SYMBOLS  PER EACH				
640.25000010	234	BLUE REFLECTORIZED PAVEMENT MARKING PAINT FOR HANDICAPPED PARKING SPACES  PER LINEAR FOOT				



**DOWNTOWN ROME WHEELS TO HEELS STREETSCAPES  
CITY OF ROME, ONEIDA COUNTY  
PIN 2650.57 / D040238**

**BASE BID**

BROUGHT FORWARD \_\_\_\_\_

ITEM NUMBER	ESTIMATED QUANTITY	ITEM DESCRIPTION WITH UNIT BID PRICE WRITTEN IN WORDS	UNIT BID PRICE		AMOUNT BID	
			DOLLARS	CENTS	DOLLARS	CENTS
645.5101	25	GROUND-MOUNTED SIGN PANELS WITHOUT Z-BARS   PER SQUARE FOOT				
645.5102	304	GROUND-MOUNTED SIGN PANELS LESS THAN OR EQUAL TO 32 SF, WITH Z-BARS   PER SQUARE FOOT				
645.11010010	9	PORCELAIN SIGN PANELS   PER EACH				
645.73000001	1	ORNAMENTAL SIGN   PER EACH				
645.81	67	TYPE A SIGN POSTS   PER EACH				

**DOWNTOWN ROME WHEELS TO HEELS STREETSCAPES  
CITY OF ROME, ONEIDA COUNTY  
PIN 2650.57 / D040238**

**BASE BID**

BROUGHT FORWARD \_\_\_\_\_

ITEM NUMBER	ESTIMATED QUANTITY	ITEM DESCRIPTION WITH UNIT BID PRICE WRITTEN IN WORDS	UNIT BID PRICE		AMOUNT BID	
			DOLLARS	CENTS	DOLLARS	CENTS
645.81090003	1	RETROREFLECTIVE SIGN POST STRIP  PER EACH				
646.21	2	REFERENCE MARKER PANEL  PER EACH				
646.22	15	DELINEATOR, SNOWPLOWING MARKER, SUPPLEMENTARY SNOWPLOWING MARKER PANELS  PER EACH				
646.31	15	STEEL POST, 1.1 LB/FT  PER EACH				
647.31	8	RELOCATE SIGN PANEL, SIGN PANEL ASSEMBLY SIZE I (UNDER 30SQUARE FEET)  PER EACH				

**DOWNTOWN ROME WHEELS TO HEELS STREETSCAPES  
CITY OF ROME, ONEIDA COUNTY  
PIN 2650.57 / D040238**

**BASE BID**

BROUGHT FORWARD \_\_\_\_\_

ITEM NUMBER	ESTIMATED QUANTITY	ITEM DESCRIPTION WITH UNIT BID PRICE WRITTEN IN WORDS	UNIT BID PRICE		AMOUNT BID	
			DOLLARS	CENTS	DOLLARS	CENTS
647.51	5	REMOVE AND DISPOSE SIGN PANEL, SIGN PANEL ASSEMBLY SIZE I (UNDER 30 SQUARE FEET)   PER EACH				
647.61	10	REMOVE AND DISPOSE SIGNS, GROUND MOUNTED TYPE A SIGN SUPPORTS AND FOUNDATIONS - SIZE I (UNDER 30 SQUARE FEET)   PER EACH				
647.83001002	1	REMOVAL & DISPOSAL OF DELINEATORS/SNOWPLOW MARKERS WITH OR WITHOUT THE POST   PER EACH				
655.05010010	5	RESETTING EXISTING SANITARY SEWER MANHOLE CASTINGS   PER EACH				
655.07020010	8	CAST FRAME F2, WITHOUT CURB BOX AND WITH RETICULINE GRATE G2   PER EACH				

**DOWNTOWN ROME WHEELS TO HEELS STREETSCAPES  
CITY OF ROME, ONEIDA COUNTY  
PIN 2650.57 / D040238**

**BASE BID**

BROUGHT FORWARD \_\_\_\_\_

ITEM NUMBER	ESTIMATED QUANTITY	ITEM DESCRIPTION WITH UNIT BID PRICE WRITTEN IN WORDS	UNIT BID PRICE		AMOUNT BID	
			DOLLARS	CENTS	DOLLARS	CENTS
655.0705	7	CAST FRAME F2, UNMOUNTABLE CURB BOX CU2   PER EACH				
655.1106	2	WELDED FRAME AND RETICULINE GRATE 6   PER EACH				
655.1202	3	MANHOLE FRAME AND COVER   PER EACH				
660.65000201	1	ALTERING UTILITY MANHOLES AND VAULTS   PER EACH				
663.31	1	RELOCATE EXISTING HYDRANT   PER EACH				

**DOWNTOWN ROME WHEELS TO HEELS STREETSCAPES  
CITY OF ROME, ONEIDA COUNTY  
PIN 2650.57 / D040238**

**BASE BID**

BROUGHT FORWARD \_\_\_\_\_

ITEM NUMBER	ESTIMATED QUANTITY	ITEM DESCRIPTION WITH UNIT BID PRICE WRITTEN IN WORDS	UNIT BID PRICE		AMOUNT BID	
			DOLLARS	CENTS	DOLLARS	CENTS
663.33	25	ADJUST EXISTING VALVE BOX ELEVATION  PER EACH				
670.0106	23	FOUNDATION FOR LIGHT STANDARDS, 6 FEET LONG  PER EACH				
670.03020011	9	RELOCATE LAMPPOST ASSEMBLY  PER EACH				
670.14480010	2	RESETTING ELECTRIC PULLBOX COVERS AND FRAMES  PER EACH				
670.15010005	14	FURNISH AND INSTALL DECORATIVE LIGHTING POLE ASSEMBLY  PER EACH				

**DOWNTOWN ROME WHEELS TO HEELS STREETSCAPES  
CITY OF ROME, ONEIDA COUNTY  
PIN 2650.57 / D040238**

**BASE BID**

BROUGHT FORWARD \_\_\_\_\_

ITEM NUMBER	ESTIMATED QUANTITY	ITEM DESCRIPTION WITH UNIT BID PRICE WRITTEN IN WORDS	UNIT BID PRICE		AMOUNT BID	
			DOLLARS	CENTS	DOLLARS	CENTS
670.2602	1,400	RIGID PLASTIC CONDUIT   PER LINEAR FOOT				
670.3006	2	PULLBOXES 5 CUBIC FEET TO 7.5 CUBIC FEET, INSIDE VOLUME(LIGHTING)   PER EACH				
670.42000002	1	LIGHTING METER CABINET WITH ALL COMPONENTS   PER EACH				
670.50610010	1	SIGN LUMINAIRE   PER EACH				
670.7003	5,425	SINGLE CONDUCTOR CABLE, NUMBER 4 GAGE   PER LINEAR FOOT				

**DOWNTOWN ROME WHEELS TO HEELS STREETSCAPES  
CITY OF ROME, ONEIDA COUNTY  
PIN 2650.57 / D040238**

**BASE BID**

BROUGHT FORWARD \_\_\_\_\_

ITEM NUMBER	ESTIMATED QUANTITY	ITEM DESCRIPTION WITH UNIT BID PRICE WRITTEN IN WORDS	UNIT BID PRICE		AMOUNT BID	
			DOLLARS	CENTS	DOLLARS	CENTS
670.7006	1,075	SINGLE CONDUCTOR CABLE, NUMBER 10 GAGE  PER LINEAR FOOT				
670.7501	1,375	GROUND WIRE NO. 6 AWG  PER LINEAR FOOT				
670.75070011	360	GROUND WIRE NUMBER 10 AWG  PER LINEAR FOOT				
670.82	10	REMOVE LAMPPOST FOUNDATION  PER EACH				
680.5001	2	POLE EXCAVATION AND CONCRETE FOUNDATION  PER CUBIC YARD				

**DOWNTOWN ROME WHEELS TO HEELS STREETSCAPES  
CITY OF ROME, ONEIDA COUNTY  
PIN 2650.57 / D040238**

**BASE BID**

BROUGHT FORWARD \_\_\_\_\_

ITEM NUMBER	ESTIMATED QUANTITY	ITEM DESCRIPTION WITH UNIT BID PRICE WRITTEN IN WORDS	UNIT BID PRICE		AMOUNT BID	
			DOLLARS	CENTS	DOLLARS	CENTS
680.5002	1	CONCRETE BASE FOR CONTROLLER CABINET   PER EACH				
680.51020009	6	ALTER ELEVATION OF PULLBOX, TYPE 2 (RAISING BELOW INCHES OR RESETTING)   PER EACH				
680.51030009	3	ALTER ELEVATION OF PULLBOX, TYPE 3 (LOWERING)   PER EACH				
680.51100010	8	CLEAN EXISTING PULLBOX   PER EACH				
680.520106	55	CONDUIT, METAL STEEL, ZINC COATED, 2"   PER LINEAR FOOT				



**DOWNTOWN ROME WHEELS TO HEELS STREETSCAPES  
CITY OF ROME, ONEIDA COUNTY  
PIN 2650.57 / D040238**

**BASE BID**

BROUGHT FORWARD \_\_\_\_\_

ITEM NUMBER	ESTIMATED QUANTITY	ITEM DESCRIPTION WITH UNIT BID PRICE WRITTEN IN WORDS	UNIT BID PRICE		AMOUNT BID	
			DOLLARS	CENTS	DOLLARS	CENTS
680.520203	10	TRAFFIC SIGNAL CONDUIT, FLEXIBLE LIQUID TIGHT STEEL, 1"  PER LINEAR FOOT				
680.54	1,500	INDUCTANCE LOOP INSTALLATION  PER LINEAR FOOT				
680.6710	5	TRAFFIC SIGNAL POLE - TOP MOUNT, 10 FEET MOUNTING HEIGHT  PER EACH				
680.71	250	SHIELDED LEAD-IN CABLE  PER LINEAR FOOT				
680.72	3,900	INDUCTANCE LOOP WIRE  PER LINEAR FOOT				

**DOWNTOWN ROME WHEELS TO HEELS STREETSCAPES  
CITY OF ROME, ONEIDA COUNTY  
PIN 2650.57 / D040238**

**BASE BID**

BROUGHT FORWARD \_\_\_\_\_

ITEM NUMBER	ESTIMATED QUANTITY	ITEM DESCRIPTION WITH UNIT BID PRICE WRITTEN IN WORDS	UNIT BID PRICE		AMOUNT BID	
			DOLLARS	CENTS	DOLLARS	CENTS
680.730514	665	SIGNAL CABLE 5 CONDUCTORS, 14 AWG  PER LINEAR FOOT				
680.77000105	1	MODIFY TRAFFIC SIGNAL INSTALLATION (ERIE AND GEORGE)  PER EACH LOCATION				
680.77000205	1	MODIFY TRAFFIC SIGNAL INSTALLATION (ERIE AND FREEDOM PLAZA)  PER EACH LOCATION				
680.77000305	1	MODIFY TRAFFIC SIGNAL INSTALLATION (ERIE AND JAMES)  PER EACH LOCATION				
680.78010005	6	ALTER PULBOX FOR CONDUITS  PER EACH				

**DOWNTOWN ROME WHEELS TO HEELS STREETSCAPES  
CITY OF ROME, ONEIDA COUNTY  
PIN 2650.57 / D040238**

**BASE BID**

BROUGHT FORWARD \_\_\_\_\_

ITEM NUMBER	ESTIMATED QUANTITY	ITEM DESCRIPTION WITH UNIT BID PRICE WRITTEN IN WORDS	UNIT BID PRICE		AMOUNT BID	
			DOLLARS	CENTS	DOLLARS	CENTS
680.813105	7	PEDESTRIAN SIGNAL MODULE - 12 INCH BI-MODAL,HAND/MAN SYMBOLS LED   PER EACH				
680.813106	14	PEDESTRIAN SIGNAL SECTION - POLYCARBONATE, TYPE I, 12 INCH   PER EACH				
680.8142	7	PEDESTRIAN SIGNAL POST TOP MOUNT ASSEMBLY   PER EACH				
680.815001	7	PEDESTRIAN SIGNAL MODULE - 12 INCH COUNTDOWN TIMER, LED   PER EACH				
680.8151	12	ACCESSIBLE PEDESTRIAN SIGNAL (APS) WITHOUT POLE   PER EACH				

**DOWNTOWN ROME WHEELS TO HEELS STREETSCAPES  
CITY OF ROME, ONEIDA COUNTY  
PIN 2650.57 / D040238**

**BASE BID**

BROUGHT FORWARD \_\_\_\_\_

ITEM NUMBER	ESTIMATED QUANTITY	ITEM DESCRIPTION WITH UNIT BID PRICE WRITTEN IN WORDS	UNIT BID PRICE		AMOUNT BID	
			DOLLARS	CENTS	DOLLARS	CENTS
680.82250101	9	REMOVE PEDESTRIAN PUSHBUTTON AND SIGN ASSEMBLY  PER EACH				
680.82250201	2	REMOVE PEDESTRIAN SIGNAL ASSEMBLIES  PER EACH				
680.82250608	2	REMOVE AND DISPOSE PEDESTRIAN POLE AND FOUNDATION  PER EACH				
680.82252310	4	RECTANGULAR RAPID FLASHING BEACON (RRFB) ASSEMBLY - TWO FORWARD BEACONS, SOLAR POWERED  PER EACH				
680.90920008	1	ELECTRIC METER SOCKET, 200 AMP, SINGLE PHASE, 240/120VOLT W/ BYPASS SWITCH FOR SIGNAL INSTALLATIONS  PER EACH				

**DOWNTOWN ROME WHEELS TO HEELS STREETSCAPES  
CITY OF ROME, ONEIDA COUNTY  
PIN 2650.57 / D040238**

**BASE BID**

BROUGHT FORWARD \_\_\_\_\_

ITEM NUMBER	ESTIMATED QUANTITY	ITEM DESCRIPTION WITH UNIT BID PRICE WRITTEN IN WORDS	UNIT BID PRICE		AMOUNT BID	
			DOLLARS	CENTS	DOLLARS	CENTS
680.93510008	3	GPS TIME SYNCHRONIZATION ANTENNA AND INTERFACE MODULE  PER EACH				
685.1102	1,072	WHITE EPOXY REFLECTORIZED PAVEMENT STRIPES - 20 MILS  PER LINEAR FOOT				
685.1202	260	YELLOW EPOXY REFLECTORIZED PAVEMENT STRIPES - 20 MILS  PER LINEAR FOOT				
685.3104	5,350	WHITE EPOXY REFLECTORIZED PAVEMENT SPECIAL STRIPES - 20 MIL PORTABLE/HAND APPLICATION  PER LINEAR FOOT				
685.3304	8	WHITE EPOXY REFLECTORIZED PAVEMENT LETTERS - 20 MIL PORTABLE/HAND APPLICATION  PER EACH				

**DOWNTOWN ROME WHEELS TO HEELS STREETSCAPES  
CITY OF ROME, ONEIDA COUNTY  
PIN 2650.57 / D040238**

**BASE BID**

BROUGHT FORWARD \_\_\_\_\_

ITEM NUMBER	ESTIMATED QUANTITY	ITEM DESCRIPTION WITH UNIT BID PRICE WRITTEN IN WORDS	UNIT BID PRICE		AMOUNT BID	
			DOLLARS	CENTS	DOLLARS	CENTS
685.3404	22	WHITE EPOXY REFLECTORIZED PAVEMENT SYMBOLS - 20 MIL PORTABLE/HAND APPLICATION  PER EACH				
698.04	288	ASPHALT PRICE ADJUSTMENT (LUMP SUM) [CALCULATED IN ESTIMATOR]  PER DOLLAR CENT	1	00	288	00
698.05	175	FUEL PRICE ADJUSTMENT (LUMP SUM) [CALCULATED IN ESTIMATOR]  PER DOLLAR CENT	1	00	175	00
697.03	139,000	FIELD CHANGE PAYMENT (FCP)  PER DOLLAR CENT	1	00	139,000	00
699.040001	1	MOBILIZATION (SHALL NOT EXCEED 4%)  PER LUMP SUM				

**DOWNTOWN ROME WHEELS TO HEELS STREETSCAPES  
CITY OF ROME, ONEIDA COUNTY  
PIN 2650.57 / D040238**

**BASE BID**

BROUGHT FORWARD \_\_\_\_\_

ITEM NUMBER	ESTIMATED QUANTITY	ITEM DESCRIPTION WITH UNIT BID PRICE WRITTEN IN WORDS	UNIT BID PRICE		AMOUNT BID	
			DOLLARS	CENTS	DOLLARS	CENTS
<b>TOTAL OR GROSS SUM WRITTEN IN WORDS (BASE BID):</b>			\$ _____			

**DOWNTOWN ROME WHEELS TO HEELS STREETSCAPES  
CITY OF ROME, ONEIDA COUNTY  
PIN 2650.57 / D040238  
BID ALTERNATIVE #1 - PARKING LOT A**

ITEM NUMBER	ESTIMATED QUANTITY	ITEM DESCRIPTION WITH UNIT BID PRICE WRITTEN IN WORDS	UNIT BID PRICE		AMOUNT BID	
			DOLLARS	CENTS	DOLLARS	CENTS
203.02	357	UNCLASSIFIED EXCAVATION AND DISPOSAL  PER CUBIC YARD				
203.03	9	EMBANKMENT IN PLACE  PER CUBIC YARD				
206.03	545	CONDUIT EXCAVATION AND BACKFILL INCLUDING SURFACE RESTORATION  PER LINEAR FOOT				
206.05	8	TEST PIT EXCAVATION  PER EACH				
304.12	113	SUBBASE COURSE, TYPE 2  PER CUBIC YARD				

NIC



**DOWNTOWN ROME WHEELS TO HEELS STREETSCAPES  
CITY OF ROME, ONEIDA COUNTY  
PIN 2650.57 / D040238  
BID ALTERNATIVE #1 - PARKING LOT A**

ITEM NUMBER	ESTIMATED QUANTITY	ITEM DESCRIPTION WITH UNIT BID PRICE WRITTEN IN WORDS	UNIT BID PRICE		AMOUNT BID	
			DOLLARS	CENTS	DOLLARS	CENTS
404.0189	35	TRUING & LEVELING F9, ASPHALT, 80 SERIES COMPACTION   PER TON				
404.0982	277	9.5 F2 TOP COURSE ASPHALT, 80 SERIES COMPACTION   PER TON				
407.0103	148	TACK COAT STRAIGHT   PER GALLON		<b>NIC</b>		
418.7303	299	ASPHALT PAVEMENT JOINT ADHESIVE   PER LINEAR FOOT				
490.30	2,020	MISCELLANEOUS COLD MILLING OF BITUMINOUS CONCRETE   PER SQUARE YARD				

**DOWNTOWN ROME WHEELS TO HEELS STREETSCAPES**  
**CITY OF ROME, ONEIDA COUNTY**  
**PIN 2650.57 / D040238**  
**BID ALTERNATIVE #1 - PARKING LOT A**

ITEM NUMBER	ESTIMATED QUANTITY	ITEM DESCRIPTION WITH UNIT BID PRICE WRITTEN IN WORDS	UNIT BID PRICE		AMOUNT BID	
			DOLLARS	CENTS	DOLLARS	CENTS
554.40	263	FILL TYPE RETAINING WALL (0 - 6FT.)  PER SQUARE FOOT				
607.91120001	231	STEEL RAILING AND HANDRAIL  PER LINEAR FOOT				
608.0101	13	CONCRETE SIDEWALKS AND DRIVEWAYS  PER CUBIC YARD			NIC	
608.020102	86	ASPHALT SIDEWALKS, DRIVEWAYS, AND BICYCLE PATHS  PER TON				
609.0212	454	STONE CURB NEAR VERTICLE FACE (NVF)  PER LINEAR FOOT				

**DOWNTOWN ROME WHEELS TO HEELS STREETSCAPES  
CITY OF ROME, ONEIDA COUNTY  
PIN 2650.57 / D040238  
BID ALTERNATIVE #1 - PARKING LOT A**

ITEM NUMBER	ESTIMATED QUANTITY	ITEM DESCRIPTION WITH UNIT BID PRICE WRITTEN IN WORDS	UNIT BID PRICE		AMOUNT BID	
			DOLLARS	CENTS	DOLLARS	CENTS
610.1404	122	TOPSOIL - SPECIAL PLANTING MIX  PER CUBIC YARD				
610.1605	824	TURF ESTABLISHMENT - PERFORMANCE  PER SQUARE YARD				
610.19	11	WATERING VEGETATION  PER 1,000 GALLON (MGAL)			<b>NIC</b>	
611.0171	17	PLANTING - MAJOR DECIDUOUS TREES - 3 INCH CALIPER BALL & BURLAP, FIELD POTTED OR FIELD BOXED  PER EACH				
611.17	17	PORTABLE DRIP IRRIGATION SYSTEM  PER EACH				

**DOWNTOWN ROME WHEELS TO HEELS STREETSCAPES  
CITY OF ROME, ONEIDA COUNTY  
PIN 2650.57 / D040238  
BID ALTERNATIVE #1 - PARKING LOT A**

ITEM NUMBER	ESTIMATED QUANTITY	ITEM DESCRIPTION WITH UNIT BID PRICE WRITTEN IN WORDS	UNIT BID PRICE		AMOUNT BID	
			DOLLARS	CENTS	DOLLARS	CENTS
611.19010024	17	POST PLANTING CARE WITH REPLACEMENT - MAJOR DECIDUOUS TREES   PER EACH				
614.060204	2	TREE REMOVAL OVER 6 INCHES TO 12 INCHES DIAMETER BREAST HEIGHT - STUMPS GRUBBED   PER EACH				
615.92010011	1	PRECAST CONCRETE STEPS (STRAIGHT)   PER CUBIC YARD			NIC	
619.01	1	BASIC WORK ZONE TRAFFIC CONTROL   PER LUMP SUM				
625.01	1	SURVEY OPERATIONS   PER LUMP SUM				

**DOWNTOWN ROME WHEELS TO HEELS STREETSCAPES  
CITY OF ROME, ONEIDA COUNTY  
PIN 2650.57 / D040238  
BID ALTERNATIVE #1 - PARKING LOT A**

ITEM NUMBER	ESTIMATED QUANTITY	ITEM DESCRIPTION WITH UNIT BID PRICE WRITTEN IN WORDS	UNIT BID PRICE		AMOUNT BID	
			DOLLARS	CENTS	DOLLARS	CENTS
627.50140008	299	CUTTING PAVEMENT   PER LINEAR FOOT				
640.25000010	567	BLUE REFLECTORIZED PAVEMENT MARKING PAINT FOR HANDICAPPED PARKING SPACES   PER LINEAR FOOT				
645.5101	14	GROUND-MOUNTED SIGN PANELS WITHOUT Z-BARS   PER SQUARE FOOT			NIC	
645.81	6	TYPE A SIGN POSTS   PER EACH				
670.0106	8	FOUNDATION FOR LIGHT STANDARDS, 6 FEET LONG   PER EACH				

**DOWNTOWN ROME WHEELS TO HEELS STREETSCAPES  
CITY OF ROME, ONEIDA COUNTY  
PIN 2650.57 / D040238  
BID ALTERNATIVE #1 - PARKING LOT A**

ITEM NUMBER	ESTIMATED QUANTITY	ITEM DESCRIPTION WITH UNIT BID PRICE WRITTEN IN WORDS	UNIT BID PRICE		AMOUNT BID	
			DOLLARS	CENTS	DOLLARS	CENTS
670.03020011	1	RELOCATE LAMPOST ASSEMBLY  PER EACH				
670.15010005	7	FURNISH AND INSTALL DECORATIVE LIGHTING POLE ASSEMBLY  PER EACH				
670.2602	545	RIGID PLASTIC CONDUIT  PER LINEAR FOOT			NIC	
670.3001	7	PULLBOXES LESS THAN 5 CUBIC FEET, INSIDE VOLUME(LIGHTING)  PER EACH				
670.7004	2,325	SINGLE CONDUCTOR CABLE, NUMBER 6 GAGE  PER LINEAR FOOT				

**DOWNTOWN ROME WHEELS TO HEELS STREETSCAPES  
CITY OF ROME, ONEIDA COUNTY  
PIN 2650.57 / D040238  
BID ALTERNATIVE #1 - PARKING LOT A**

ITEM NUMBER	ESTIMATED QUANTITY	ITEM DESCRIPTION WITH UNIT BID PRICE WRITTEN IN WORDS	UNIT BID PRICE		AMOUNT BID	
			DOLLARS	CENTS	DOLLARS	CENTS
670.7006	475	SINGLE CONDUCTOR CABLE, NUMBER 10 GAGE  PER LINEAR FOOT				
670.7501	600	GROUND WIRE NO. 6 AWG  PER LINEAR FOOT				
670.75070011	145	GROUND WIRE NUMBER 10 AWG  PER LINEAR FOOT			NIC	
670.80	1	REMOVE AND STORE EXISTING LAMP POST ASSEMBLY  PER EACH				
670.82	2	REMOVE LAMPPOST FOUNDATION  PER EACH				

**DOWNTOWN ROME WHEELS TO HEELS STREETSCAPES  
CITY OF ROME, ONEIDA COUNTY  
PIN 2650.57 / D040238  
BID ALTERNATIVE #1 - PARKING LOT A**

ITEM NUMBER	ESTIMATED QUANTITY	ITEM DESCRIPTION WITH UNIT BID PRICE WRITTEN IN WORDS	UNIT BID PRICE		AMOUNT BID	
			DOLLARS	CENTS	DOLLARS	CENTS
685.3104	1,362	WHITE EPOXY REFLECTORIZED PAVEMENT SPECIAL STRIPES - 20 MIL PORTABLE/HAND APPLICATION   PER LINEAR FOOT				
685.3404	4	WHITE EPOXY REFLECTORIZED PAVEMENT SYMBOLS - 20 MIL PORTABLE/HAND APPLICATION   PER EACH				
698.04	398	ASPHALT PRICE ADJUSTMENT (LUMP SUM) [CALCULATED IN ESTIMATOR]   PER DOLLAR CENT	1	00	NIC 398	00
698.05	100	FUEL PRICE ADJUSTMENT (LUMP SUM) [CALCULATED IN ESTIMATOR]   PER DOLLAR CENT	1	00	100	00
697.03	24,000	FIELD CHANGE PAYMENT (FCP)   PER DOLLAR CENT	1	00	24,000	00



**DOWNTOWN ROME WHEELS TO HEELS STREETSCAPES**

**CITY OF ROME, ONEIDA COUNTY**

**PIN 2650.57 / D040238**

**BID ALTERNATIVE #1 - PARKING LOT A**

ITEM NUMBER	ESTIMATED QUANTITY	ITEM DESCRIPTION WITH UNIT BID PRICE WRITTEN IN WORDS	UNIT BID PRICE		AMOUNT BID	
			DOLLARS	CENTS	DOLLARS	CENTS
699.040001	-	MOBILIZATION (SHALL NOT EXCEED 4%)   PER LUMP SUM				
<b>TOTAL OR GROSS SUM WRITTEN IN WORDS (BID ALTERNATIVE #1):</b>  _____			\$ _____			

**NIC**

**DOWNTOWN ROME WHEELS TO HEELS STREETSCAPES  
CITY OF ROME, ONEIDA COUNTY  
PIN 2650.57 / D040238**

**BID ALTERNATIVE #2 - FLEXIPAVE BUFFER TREATMENT**

ITEM NUMBER	ESTIMATED QUANTITY	ITEM DESCRIPTION WITH UNIT BID PRICE WRITTEN IN WORDS	UNIT BID PRICE		AMOUNT BID	
			DOLLARS	CENTS	DOLLARS	CENTS
304.12	43	SUBBASE COURSE, TYPE 2  PER CUBIC YARD				
420.98010104	6,604	POROUS PAVING SURFACE PRODUCT, TYPE 01  PER SQUARE FOOT				
608.01020005	(82)	COLORED AND IMPRINTED PORTLAND CEMENT CONCRETE SIDEWALK  PER CUBIC YARD				
697.03	4,000	FIELD CHANGE PAYMENT (FCP)  PER DOLLAR CENT	1	00	4,000	00
699.040001	1	MOBILIZATION (SHALL NOT EXCEED 4%)  PER LUMP SUM				

**DOWNTOWN ROME WHEELS TO HEELS STREETSCAPES**  
**CITY OF ROME, ONEIDA COUNTY**  
**PIN 2650.57 / D040238**  
**BID ALTERNATIVE #2 - FLEXIPAVE BUFFER TREATMENT**

ITEM NUMBER	ESTIMATED QUANTITY	ITEM DESCRIPTION WITH UNIT BID PRICE WRITTEN IN WORDS	UNIT BID PRICE		AMOUNT BID	
			DOLLARS	CENTS	DOLLARS	CENTS
<b>TOTAL OR GROSS SUM WRITTEN IN WORDS (BID ALTERNATIVE #2):</b> <hr style="border: 0; border-top: 1px solid black; margin: 5px 0;"/> <hr style="border: 0; border-top: 1px solid black; margin: 5px 0;"/> <hr style="border: 0; border-top: 1px solid black; margin: 5px 0;"/>			\$ _____			

**DOWNTOWN ROME WHEELS TO HEELS STREETSCAPES  
CITY OF ROME, ONEIDA COUNTY  
PIN 2650.57 / D040238  
BID ALTERNATIVE #3 - FLEXIPAVE MEDIAN TREATMENT**

ITEM NUMBER	ESTIMATED QUANTITY	ITEM DESCRIPTION WITH UNIT BID PRICE WRITTEN IN WORDS	UNIT BID PRICE		AMOUNT BID	
			DOLLARS	CENTS	DOLLARS	CENTS
304.12	43	SUBBASE COURSE, TYPE 2  PER CUBIC YARD				
420.98010104	6,482	POROUS PAVING SURFACE PRODUCT, TYPE 01  PER SQUARE FOOT				
608.01020005	(82)	COLORED AND IMPRINTED PORTLAND CEMENT CONCRETE SIDEWALK  PER CUBIC YARD				
697.03	4,000	FIELD CHANGE PAYMENT (FCP)  PER DOLLAR CENT	1	00	4,000	00
699.040001	1	MOBILIZATION (SHALL NOT EXCEED 4%)  PER LUMP SUM				

**DOWNTOWN ROME WHEELS TO HEELS STREETSCAPES  
CITY OF ROME, ONEIDA COUNTY  
PIN 2650.57 / D040238**

**BID ALTERNATIVE #3 - FLEXIPAVE MEDIAN TREATMENT**

ITEM NUMBER	ESTIMATED QUANTITY	ITEM DESCRIPTION WITH UNIT BID PRICE WRITTEN IN WORDS	UNIT BID PRICE		AMOUNT BID	
			DOLLARS	CENTS	DOLLARS	CENTS
<b>TOTAL OR GROSS SUM WRITTEN IN WORDS (BID ALTERNATIVE #3):</b>			\$ _____			

**DOWNTOWN ROME WHEELS TO HEELS STREETSCAPES  
CITY OF ROME, ONEIDA COUNTY  
PIN 2650.57 / D040238**

**BID ALTERNATIVE #4 - DECORATIVE SINGLE SLOPE CONCRETE MEDIAN BARRIER**

ITEM NUMBER	ESTIMATED QUANTITY	ITEM DESCRIPTION WITH UNIT BID PRICE WRITTEN IN WORDS	UNIT BID PRICE		AMOUNT BID	
			DOLLARS	CENTS	DOLLARS	CENTS
304.12	15	SUBBASE COURSE, TYPE 2  PER CUBIC YARD				
404.0982	1	9.5 F2 TOP COURSE ASPHALT, 80 SERIES COMPACTION  PER TON				
606.31120010	760	SINGLE SLOPE FULL SECTION CONCRETE BARRIER CAST WITH SIMULATED STONE PATTERN FINISH (PRECAST)  PER LINEAR FOOT				
608.01020005	(20)	COLORED AND IMPRINTED PORTLAND CEMENT CONCRETE SIDEWALK  PER CUBIC YARD				
609.0212	36	STONE CURB NEAR VERTICLE FACE (NVF)  PER LINEAR FOOT				

**DOWNTOWN ROME WHEELS TO HEELS STREETSCAPES  
CITY OF ROME, ONEIDA COUNTY  
PIN 2650.57 / D040238**

**BID ALTERNATIVE #4 - DECORATIVE SINGLE SLOPE CONCRETE MEDIAN BARRIER**

ITEM NUMBER	ESTIMATED QUANTITY	ITEM DESCRIPTION WITH UNIT BID PRICE WRITTEN IN WORDS	UNIT BID PRICE		AMOUNT BID	
			DOLLARS	CENTS	DOLLARS	CENTS
654.05	5	CONCRETE FOUNDATION FOR IMPACT ATTENUATOR  <hr/> <div style="text-align: right;">PER CUBIC YARD</div>				
654.5022	2	EXPENDABLE IMPACT ATTENUATOR, TL 2, > 2 FT OBSTRUCTION WIDTH <= 5 FT  <hr/> <div style="text-align: right;">PER EACH</div>				
697.03	18,000	FIELD CHANGE PAYMENT (FCP)  <hr/> <div style="text-align: right;">PER DOLLAR CENT</div>	1	00	18,000	00
699.040001	1	MOBILIZATION (SHALL NOT EXCEED 4%)  <hr/> <div style="text-align: right;">PER LUMP SUM</div>				
<b>TOTAL OR GROSS SUM WRITTEN IN WORDS (BID ALTERNATIVE #4):</b> <hr/> <hr/> <hr/>			\$ _____			

## **APPENDIX 12-1A**

### **CONSTRUCTION CONTRACT REQUIREMENTS FILLABLE FORMS**

#### **Contents**

**NON-COLLUSIVE BIDDING CERTIFICATION**

**OFFERER DISCLOSURE OF PRIOR NON-RESPONSIBILITY DETERMINATIONS**

**COMBINED CERTIFICATION FORM**

**ALL FORMS MUST BE INCLUDED IN ALL FEDERAL AID CONTRACTS AND MUST BE INCLUDED IN EACH BID PROPOSAL.**



REVISED November 2021

**NON-COLLUSIVE BIDDING CERTIFICATION  
BIDDER INFORMATION**

Bidder to provide information listed below:

Bidder Address: [redacted]  
Street or P. O. Box No.  
[redacted]  
City  
[redacted] [redacted]  
State ZIP

Federal Identification No.: [redacted]

Name of Contact Person: [redacted]

Phone # of Contact Person: [redacted]

**If Bidder is a Corporation:**

President's Name & Address:  
[redacted]

Secretary's Name & Address:  
[redacted]

Treasurer's Name & Address:  
[redacted]

**If Bidder is a Partnership:**

Partner's Name & Address:  
[redacted]

Partner's Name & Address:  
[redacted]

**If Bidder is a Sole Proprietorship:**

Owner's Name & Address:  
[redacted]

**THIS PAGE MUST BE INCLUDED IN ALL FEDERAL AID CONTRACTS AND MUST BE INCLUDED IN EACH BID PROPOSAL.**

REVISED November 2021

### Offerer Disclosure of Prior Non-Responsibility Determinations

Name of Individual of Entity Seeking to Enter into the Procurement Contract:

█

Address: █

Name and Title of Person Submitting this Form: █

Contract Procurement Number: █

Date: █

1. Has any Governmental Entity made a finding of non-responsibility regarding the individual or entity seeking to enter into the Procurement Contract in the previous four years?

NO  YES

If yes, please answer the next questions:

2. Was the basis for the finding of non-responsibility due to a violation of State Finance Law § 139-j?

NO  YES

3. Was the basis for the finding of non-responsibility due to the intentional provision of false or incomplete information to a Governmental Entity?

NO  YES

4. If you answered yes to any of the above questions, please provide details regarding the finding of non-responsibility below.

Governmental Entity: █

Date of Finding of Non-Responsibility: █

Basis of Finding of Non-Responsibility: █

*(Add additional pages as necessary.)*

5. Has any Governmental Entity or other governmental agency terminated or withheld a Procurement Contract with the above-named individual or entity due to the intentional provision of false or incomplete information?

NO  YES

6. If yes, please provide details below.

Governmental Entity: █

Date of Termination or Withholding of Contract: █

Basis of Termination or Withholding: █

*(Add additional pages as necessary.)*

Offerer certifies that all information provided to the Governmental Entity with respect to State Finance Law §139-k is complete, true and accurate.

By: \_\_\_\_\_ Date: █

Signature

Name: █

Title: █

REVISED November 2021

### COMBINED CERTIFICATION FORM

**BY EXECUTING THIS DOCUMENT, THE CONTRACTOR AGREES TO:**

1. Perform all work listed in accordance with the Contract Documents including all amendments, at the prices bid; subject to the Changed Conditions provisions if applicable,
2. Accompany this proposal with a bid bond, certified check or bank cashier's check for the specified amount of deposit required,
3. All the terms and conditions of the non-collusive bidding certifications required by §139-d of the State Finance Law and 2 CFR Part 1200,
4. Certify, under penalty of perjury, as to the current history regarding suspensions, debarments, voluntary exclusions, determinations of ineligibility, indictments, convictions or civil judgments required by FHWA Form 1273 Required Contract Provisions Federal-Aid Construction Contracts-Section X "Certification Regarding Debarment, Suspension, Ineligibility and Voluntary Exclusion",
5. Certify that no Federal appropriated funds have been paid or will be paid, to any person for lobbying a Federal official or employee, or disclosure was made in accordance with 31 USC 1352 required by FHWA Form 1273 Required Contract Provisions Federal-Aid Construction Contracts-Section XI "Certification Regarding Use of Contract Funds for Lobbying",
6. Attest that its performance of the services outlined in this proposal does not and will not create a conflict of interest with nor position the firm to breach any other contract currently in force with the State of New York,
7. Certify that it understands the prohibitions under the Federal False Claims Act (31 USC §3729) and the New York State False Claims Act (NYS Finance Law Article 13),
8. Certify that all information provided to the Department with respect to the requirements contained in the Procurement Lobbying Law (State Finance Laws §139-j and §139-k) is complete, true and accurate,
9. Affirm, under penalty of perjury, that all the responses provided to the Department with respect to its submitted Form CCA-2 New York State Vendor Responsibility Questionnaire For-Profit Construction, are complete, true, and accurate, and further affirms and acknowledges that it must remain a responsible Contractor throughout the duration of the contract, in accordance with §105-05 Vendor Responsibility,
10. Provide commitments to meet the established DBE goal(s) prior to award or demonstrate good faith efforts to do so,
11. By submission of this bid, each bidder and each person signing on behalf of any bidder certifies, and in the case of a joint bid each party thereto certifies as to its own organization, under penalty of perjury, that the bidder has and has implemented a written policy addressing sexual harassment prevention in the workplace and provides annual sexual harassment prevention training to all of its employees. Such policy shall, at a minimum, meet the requirements of Section 201-g of the New York State Labor Law.

REVISED November 2021

12. Certify to all other clauses required by this proposal and contained herein.

Dated [redacted], 20 [redacted]

[redacted]

Legal Name of person, firm or corporation

By \_\_\_\_\_  
Signature (Title)

**(Acknowledgment by Individual Contractor)**

STATE OF NEW YORK )  
COUNTY OF [redacted] ) SS:

On this [redacted] day of [redacted], 20 [redacted], before me personally came [redacted], to me known and known to me to be described in and who executed the foregoing instrument, and that he/she acknowledged that he/she executed the same.

Notary Public

**(Acknowledgment by Individual Contractor, If a Corporation)**

STATE OF NEW YORK )  
COUNTY OF [redacted] ) SS:

On this [redacted] day of [redacted], 20 [redacted], before me personally came [redacted], to me known and known to me to be the person who executed the above instrument, who being duly sworn by me, did depose and say that he/she resides at [redacted], and that he/she is the [redacted] of the [redacted] the corporation described in and which executed the above instrument, and that he/she signed his/her name thereto on behalf of said Corporation by order of the Board of Directors of said Corporation.

\_\_\_\_\_  
Notary Public

**(Acknowledgment of Co-Partnership Contractor)**

STATE OF NEW YORK )  
COUNTY OF [redacted] ) SS:

On this [redacted] day of [redacted], 20 [redacted], before me personally came [redacted], to me known and known to me to be the person described in and who executed the above instrument, who, being duly sworn by me, did for himself/herself depose and say that he/she is a member of the firm of [redacted], consisting of himself/herself and [redacted], and that he/she executed the foregoing instrument in the firm name of [redacted] and that he/she had authority to sign same, and did duly acknowledge to me that he/she executed same as the act and deed of said firm of [redacted] for the uses and purposes mentioned herein.

\_\_\_\_\_  
Notary Public

**BID BOND**

Any singular reference to Bidder, Surety, Owner or other party shall be considered plural where applicable.

BIDDER *(Name and Address)*:

SURETY *(Name and Address of Principal Place of Business)*:

OWNER *(Name and Address)*:

**BID**

Bid Due Date:  
Description *(Project Name and Include Location)*:

**BOND**

Bond Number:  
Date *(Not earlier than Bid due date)*:  
Penal sum \_\_\_\_\_

\_\_\_\_\_ \$ \_\_\_\_\_  
(Words) (Figures)

Surety and Bidder, intending to be legally bound hereby, subject to the terms set forth below, do each cause this Bid Bond to be duly executed by an authorized officer, agent, or representative.

**BIDDER**

**SURETY**

\_\_\_\_\_  
Bidder's Name and Corporate Seal (Seal)

\_\_\_\_\_  
Surety's Name and Corporate Seal (Seal)

By: \_\_\_\_\_  
Signature

By: \_\_\_\_\_  
Signature (Attach Power of Attorney)

\_\_\_\_\_  
Print Name

\_\_\_\_\_  
Print Name

\_\_\_\_\_  
Title

\_\_\_\_\_  
Title

Attest: \_\_\_\_\_  
Signature

Attest: \_\_\_\_\_  
Signature

\_\_\_\_\_  
Title

\_\_\_\_\_  
Title

*Note: Above addresses are to be used for giving any required notice. Provide execution by any additional parties, such as joint venturers, if necessary.*

1. Bidder and Surety, jointly and severally, bind themselves, their heirs, executors, administrators, successors, and assigns to pay to Owner upon default of Bidder the penal sum set forth on the face of this Bond. Payment of the penal sum is the extent of Bidder's and Surety's liability. Recovery of such penal sum under the terms of this Bond shall be Owner's sole and exclusive remedy upon default of Bidder.
2. Default of Bidder shall occur upon the failure of Bidder to deliver within the time required by the Bidding Documents (or any extension thereof agreed to in writing by Owner) the executed Agreement required by the Bidding Documents and any performance and payment bonds required by the Bidding Documents.
3. This obligation shall be null and void if:
  - 3.1 Owner accepts Bidder's Bid and Bidder delivers within the time required by the Bidding Documents (or any extension thereof agreed to in writing by Owner) the executed Agreement required by the Bidding Documents and any performance and payment bonds required by the Bidding Documents, or
  - 3.2 All Bids are rejected by Owner, or
  - 3.3 Owner fails to issue a Notice of Award to Bidder within the time specified in the Bidding Documents (or any extension thereof agreed to in writing by Bidder and, if applicable, consented to by Surety when required by Paragraph 5 hereof).
4. Payment under this Bond will be due and payable upon default of Bidder and within 30 calendar days after receipt by Bidder and Surety of written notice of default from Owner, which notice will be given with reasonable promptness, identifying this Bond and the Project and including a statement of the amount due.
5. Surety waives notice of any and all defenses based on or arising out of any time extension to issue Notice of Award agreed to in writing by Owner and Bidder, provided that the total time for issuing Notice of Award including extensions shall not in the aggregate exceed 120 days from Bid due date without Surety's written consent.
6. No suit or action shall be commenced under this Bond prior to 30 calendar days after the notice of default required in Paragraph 4 above is received by Bidder and Surety and in no case later than one year after Bid due date.
7. Any suit or action under this Bond shall be commenced only in a court of competent jurisdiction located in the state in which the Project is located.
8. Notices required hereunder shall be in writing and sent to Bidder and Surety at their respective addresses shown on the face of this Bond. Such notices may be sent by personal delivery, commercial courier, or by United States Registered or Certified Mail, return receipt requested, postage pre-paid, and shall be deemed to be effective upon receipt by the party concerned.
9. Surety shall cause to be attached to this Bond a current and effective Power of Attorney evidencing the authority of the officer, agent, or representative who executed this Bond on behalf of Surety to execute, seal, and deliver such Bond and bind the Surety thereby.
10. This Bond is intended to conform to all applicable statutory requirements. Any applicable requirement of any applicable statute that has been omitted from this Bond shall be deemed to be included herein as if set forth at length. If any provision of this Bond conflicts with any applicable statute, then the provision of said statute shall govern and the remainder of this Bond that is not in conflict therewith shall continue in full force and effect.
11. The term "Bid" as used herein includes a Bid, offer, or proposal as applicable.

**AFFIDAVIT OF WORKERS COMPENSATION**

State of \_\_\_\_\_

SS:

County of \_\_\_\_\_

\_\_\_\_\_

of \_\_\_\_\_

being duly sworn, deposes and says that he now carries or that he has applied for a Workers Compensation Policy to cover the operations, as set forth in the preceding contract, and to comply with the provisions thereof.

Signed: \_\_\_\_\_

Subscribed and sworn to before me

this \_\_\_\_\_ day of \_\_\_\_\_, 20\_\_\_\_\_

\_\_\_\_\_  
Notary Public

**CERTIFICATION OF COMPLAINE IRAN DIVESTMENT ACT**

As a result of the Iran Divestment Act of 2012 (Act), Chapter 1 of the 2012 Laws of New York, a new provision has been added to the State Finance Law (SFL), § 165-a, effective April 12, 2012. Under the Act, the Commissioner of the Office of General Services (OGS) will be developing a list (prohibited entities list) of “persons” who are engaged in “investment activities in Iran” (both are defined terms in the law). Pursuant to SFL § 165-a(3)(b), the initial list is expected to be issued no later than 120 days after the Act’s effective date, at which time it will be posted on the OGS website.

By submitting a bid in response to this solicitation or by assuming the responsibility of a Contract awarded hereunder, each Bidder/Contractor, any person signing on behalf of the Bidder/Contractor and any assignee or subcontractor and, in the case of a joint bid, each party thereto, certifies, under penalty of perjury, that once the Prohibited Entities List is posted on the OGS website, that to the best of its knowledge and belief, that each Bidder/Contractor and any subcontractor or assignee is not identified on the Prohibited Entities List created pursuant to SFL § 165-a(3)(b).

Additionally, Bidder/Contractor is advised that once the Prohibited Entities List is posted on the OGS website, any Contractor seeking to renew or extend a Contract or assume the responsibility of a Contract awarded in response to this solicitation, must certify at the time the Contract is renewed, extended or assigned that it is not included on the Prohibited Entities List.

During the term of the Contract, should the Municipality receive information that a Bidder/Contractor is in violation of the above-referenced certification, the Municipality will offer the person or entity an opportunity to respond. If the person or entity fails to demonstrate that it has ceased its engagement in the investment which is in violation of the Act within 90 days after the determination of such violation, then the Municipality shall take such action as may be appropriate including, but not limited to, imposing sanctions, seeking compliance, recovering damages, or declaring the Bidder/Contractor in default.

The Municipality reserves the right to reject any bid or request for assignment for a Bidder/Contractor that appears on the Prohibited Entities List prior to the award of a contract, and to pursue a responsibility review with respect to any Bidder/Contractor that is awarded a contract and subsequently appears on the Prohibited Entities List.

I \_\_\_\_\_, being duly sworn, deposes and says that he/she is the \_\_\_\_\_ of \_\_\_\_\_ and neither the Bidder/Contractor nor any proposed subcontractor is identified on the Prohibited Entities List.

\_\_\_\_\_  
Signed

SWORN to before me this

\_\_\_\_\_ day of \_\_\_\_\_

20\_\_

Notary Public: \_\_\_\_\_



**DISADVANTAGED/MINORITY/WOMENS BUSINESS ENTERPRISE (D/M/WBE)  
UTILIZATION GOALS**

The Department has established the following utilization goal(s) for this contract, expressed as a percentage of the total contract bid price. For clarification of Disadvantaged Business Enterprise (DBE) Utilization, Minority Business Enterprise (MBE), and Women’s Business Enterprise (WBE) Utilization, Refer to Appendix A.

Disadvantaged Business Enterprise (DBE) Utilization Goal 6% (Federal Aid Only)

Minority Business Enterprise (MBE) Goal 2.1% (Non-Federal-Aid Only)

Women’s Business Enterprise (WBE) Goal 6.9% (Non-Federal-Aid Only)

Service-Disabled Veteran-Owned Business (SDVOB) Goal 0% (Non-Federal-Aid Only)

The NYSUCP DBE Directory is located at: <https://nysucp.newnycontracts.com/>

The NYS M/WBE Directory is located at: <https://ny.newnycontracts.com/>

The NYS SDVOB Directory is located at: <https://online.ogs.ny.gov/SDVOB/search>

**Disadvantaged Business Enterprise Officer**

The Bidder shall designate and enter below the name of the Disadvantaged/Minority/Women’s Business Enterprise Officer who will have the responsibility for the D/M/WBE Utilization.

Bidder Designated D/M/WBE Officer

\_\_\_\_\_ (Name)

\_\_\_\_\_ (Title)

Telephone Number

( ) \_\_\_\_\_

**RETURN THIS PAGE WITH BID**

## D/M/WBE PRE-AWARD UTILIZATION PACKAGE

Within five (5) calendar days after bid letting, the Apparent Low Bidder shall submit a complete D/M/WBE Pre-Award Utilization Package, as outlined per section 102-12 H of the NYSDOT Specifications. <https://www.dot.ny.gov/main/business-center/engineering/specifications/busi-e-standards-usc>.

This package shall be submitted to NYSDOT through the EBO software.  
<https://www.dot.ny.gov/dotapp/ebo>

If the contractor does not have an EBO account, they are directed to obtain an account. Instructions for obtaining a login can be found on the Department's website here: <https://www.dot.ny.gov/dotapp/ebo/instructions> . The processing time to obtain a login is included in the five (5) calendar day period therefore; the contractor shall work on obtaining the necessary DBE data upon identification of being the apparent low bidder at the project letting. Obtaining an EBO login is free; however there is a onetime \$75 training fee. **All contractors on the project site and their subs must have EBO access.**

If an EBO account is not obtained prior to five (5) calendar days of the bid opening, the AAP-10 forms must be completed and submitted to the municipality and engineer for forwarding onto NYSDOT. [https://www.dot.ny.gov/main/business-center/contractors/construction-division/construction-repository/AAP\\_10.pdf](https://www.dot.ny.gov/main/business-center/contractors/construction-division/construction-repository/AAP_10.pdf)

**If the DBE goals cannot be met within the 5 day time frame, your bid may be dismissed at the discretion of the owner.**

**Federal DBE Commitment and GFE Bid Requirements**

Letting Date:

**Proposer Name**

**Address:**

**PIN**   
**Contract #**   
**DBE Goal**  % as Stated in the Advertisement

We hereby submit a DBE commitment of  % for the above-referenced project.

Identified below are the commitment(s) to certified\* DBE's for this contract:

<u>DBE Name:</u>	<u>Work Category*</u>	<u>Description of Work</u>	<u>DBE Credit % (A)</u>	<u>Commitment (B)</u>	<u>DBE Credit (AxB)</u>
Example Company: Drainage R Us Address: 2543 Lexington Street, Troy, NY 12180	Construction	Closed Drainage Installation	100	\$1,120,000	\$1,120,000
Address: <input type="text"/>					
Address: <input type="text"/>					
Address: <input type="text"/>					
Address: <input type="text"/>					
Address: <input type="text"/>					
Address: <input type="text"/>					

*\*Only submit DBE(s) that you have verified are certified to perform/supply the identified commitments.* **Total Commitment:**

You are required to have firm commitments at the time of Letting. Within 5 calendar days of notification as apparent Low Bidder, you shall enter exactly (as shown) all of the DBE commitments identified here, into Equitable Business Opportunity Solution (EBO), NYSDOT's civil rights reporting software. No substitutions or reductions in commitments will be allowed without prior approval by the Department, in accordance with 49 CFR 26.53(f)(3).

*NOTE: Bids may be submitted below the DBE Goal. If you do not meet the DBE Goal and are identified as apparent Low Bidder, you will be required to submit a Good Faith Effort package to the Pre-Award Unit, within 5 calendar days of notification.*

<u>*Key:</u>	<u>Work Categories:</u>	<u>DBE Credit %</u>
	Construction	100
	Fabricator	100
	Manufacturer	100
	Material Supplier	60
	Professional Service	100
	Trucking Firm	100

Submitted By:

Enter Proposers Contact Information

Name:

Title:

Company Federal Tax ID XX-XXXXXXX

**SEXUAL HARASSMENT PREVENTION CERTIFICATION FOR CONSTRUCTION CONTRACT BIDS**  
**(Per NYSDOT EB 18-047, signed 12/20/2018)**

By submission of this bid, each bidder and each person signing on behalf of any bidder certifies, and in the case of a joint bid each party thereto certifies as to its own organization, under penalty of perjury, that the bidder has and has implemented a written policy addressing sexual harassment prevention in the workplace and provides annual sexual harassment prevention training to all of its employees. Such policy shall, at a minimum, meet the requirements of section two hundred one-g of the New York State Labor Law.

I \_\_\_\_\_, being duly sworn, deposes and says that he/she is the  
\_\_\_\_\_ of \_\_\_\_\_ and certify

\_\_\_\_\_ is compliance with maintaining a written policy addressing sexual harassment prevention in the workplace and providing annual sexual harassment prevention training to all their employees.

SWORN to before me this

\_\_\_\_\_ day of \_\_\_\_\_

20\_\_

Notary Public: \_\_\_\_\_

**NEW YORK STATE VENDOR RESPONSIBILITY QUESTIONNAIRE  
FOR PROFIT CONSTRUCTION (CCA-2)**

**INSTRUCTIONS FOR COMPLETING THE NEW YORK STATE  
VENDOR RESPONSIBILITY QUESTIONNAIRE FOR PROFIT CONSTRUCTION**

Please Read Before Completing Questionnaire

- Complete all sections of the Questionnaire.
- Submit this form as required by the contracting agency after being announced the low bidder for any competitively bid contract, or when proposed for subcontract work. If you have submitted one within six (6) months of the bid date with any contracting agency, as long as the information remains unchanged and accurate, you may submit a complete certified copy of that form, together with an Affidavit of No Change, to the Agency with which you are bidding. A contracting agency may require additional information deemed necessary for its review. Whenever more space is needed to answer any question or you wish to give further explanation, complete by attaching extra pages. All questions must be answered.
- For each “Yes” answer in Sections IV, V, VI, VII, VIII and IX, add additional explanatory material. For question 7.2, if your firm has OSHA citations, attach copies of each citation.
- A certified annual financial statement, including Accountant’s Review Report and Accompanying Notes, will be acceptable in lieu of completing the financial disclosure forms in the questionnaire.
- If you wish material in this Questionnaire to be held as confidential and exempt from disclosure under Freedom of Information, place an asterisk in front of all information you do not want disclosed to outside sources.
- This Questionnaire is generally valid for one calendar year, unless major changes have occurred (firm purchased by another business, bankruptcy, etc.), in which case re-submittal is required.
- Submit completed questionnaires marked “CONFIDENTIAL” to:

NEW YORK STATE DEPARTMENT OF TRANSPORTATION  
CONTRACT MANAGEMENT BUREAU  
50 WOLF ROAD, 1st FLOOR, SUITE 1CM  
ALBANY, NY 12232  
(518) 457-1564

**NEW YORK STATE VENDOR RESPONSIBILITY QUESTIONNAIRE  
FOR PROFIT CONSTRUCTION (CCA-2)**

<b>BUSINESS ENTITY INFORMATION</b>				
<u>Legal Business Name*</u>			<u>EIN</u>	
Complete Address of the <u>Principal Place of Business</u>			Phone Number	Fax Number
E-mail		Website		
Authorized Contact for this Questionnaire				
Name			Phone Number	Fax Number
Title			E-mail	
Additional <u>Business Entity</u> Identities: If applicable, list any other <u>DBA</u> , <u>Trade Name</u> , <u>Former Name</u> , <u>Other Identity</u> , or <u>EIN</u> used in the last five (5) years, the state or county where filed and the status (active or inactive).				
Type (DBA, Trade Name, Other)	Name	EIN	State or County where filed	Status (ACTIVE OR INACTIVE)

<b>I. BUSINESS CHARACTERISTICS</b>		
<b>1.0 <u>Business Entity</u> Type -</b>		
a) <u>Corporation</u> (including <u>P.C.</u> )	Date of Incorporation	
b) <u>Limited Liability Company</u> (LLC or PLLC)	Date Organized	
c) <u>Limited Liability Partnership</u>	Date of Registration	
d) <u>Limited Partnership</u>	Date Established	
e) <u>General Partnership</u>	Date Established	County (if formed in NYS)
f) <u>Sole Proprietor</u>	How many years in business?	
g) <u>Other</u>	Date Established	
If Other, explain:		
<b>1.1 Was the <u>Business Entity</u> formed in New York State?</b>	Yes	No
If "No" indicate jurisdiction where the <u>Business Entity</u> was formed: United States      State Other                  Country		

\*All under lined terms are defined in the "New York State Vendor Responsibility Definitions List", which can be found at: <http://www.osc.state.ny.us/vendrep/documents/definitions.pdf>.

*Note: These terms may not have their ordinary, common or traditional meanings. Each vendor is strongly encouraged to read the respective definitions for any and all underlined terms. By submitting this questionnaire, the vendor agrees to be bound by the terms as defined in the "New York State Vendor Responsibility Definitions List" as it existed at the time of certifications.*

**NEW YORK STATE VENDOR RESPONSIBILITY QUESTIONNAIRE  
FOR PROFIT CONSTRUCTION (CCA-2)**

EIN:

<b>I. BUSINESS CHARACTERISTICS</b>			
1.2 Is the <b>Business Entity</b> currently <b>registered to do business in New York State</b> ? <i>Note: Select "Not Required" if the <b>Business Entity</b> is a <b>Sole Proprietor</b> or <b>General Partnership</b></i>			Yes    No Not Required
If "No," explain why the <b>Business Entity</b> is not required to be <b>registered to do business in New York State</b> :			
1.3 Is the responding <b>Business Entity</b> a <b>Joint Venture</b> ? <i>Note: If the submitting <b>Business Entity</b> is a <b>Joint Venture</b>, also submit a separate questionnaire for each <b>Business Entity</b> comprising the <b>Joint Venture</b>.</i>			Yes    No
1.4 If the <b>Business Entity's Principal Place of Business</b> is not in New York State, does the <b>Business Entity</b> maintain an office in New York State? <i>(Select "N/A" if <b>Principal Place of Business</b> is in New York State.)</i>			Yes    No N/A
If "Yes," provide the address and telephone number for one office located in New York State.			
1.5 Is the <b>Business Entity</b> a New York State certified <b>Minority-Owned Business Enterprise</b> , or <b>Women-Owned Business Enterprise</b> , or <b>New York State Small Business</b> , or federally certified <b>Disadvantaged Business Enterprise</b> ?			Yes    No
If "Yes," check all that apply: New York State certified <b>Minority-Owned Business Enterprise</b> (MBE) New York State certified <b>Women-Owned Business Enterprise</b> (WBE) New York State <b>Small Business</b> Federally certified <b>Disadvantaged Business Enterprise</b> (DBE)			
1.6 Identify each person who is, or has been within the past five (5) years, a <b>Business Entity Official</b> or <b>Principal Owner</b> of 5.0% or more of the firm's shares, or one of the five largest shareholders or a director, an officer, a partner or a proprietor. <b>Joint Ventures: Provide information for all firms involved.</b> <i>(Attach additional pages if necessary.)</i>			
Name	Title	Percentage Ownership <i>(Enter 0% if not applicable)</i>	Employment Status with the Firm
			Current    Former
			Current    Former
			Current    Former
			Current    Former
<b>II. AFFILIATE and JOINT VENTURE RELATIONSHIPS</b>			
2.0 Are there any other <b>construction</b> -related firms in which, now or in the past five years, the submitting <b>Business Entity</b> or any of the individuals listed in question 1.6 either owned or owns 5.0% or more of the shares of, or was or is one of the five largest shareholders or a director, officer, partner or proprietor of said other firm?			Yes    No
Firm/Company Name	Firm/Company EIN <i>(If Available)</i>	Firm/Company's Primary Business Activity	

**NEW YORK STATE VENDOR RESPONSIBILITY QUESTIONNAIRE  
FOR PROFIT CONSTRUCTION (CCA-2)**

EIN:

<b>II. AFFILIATE and JOINT VENTURE RELATIONSHIPS</b>		
Firm/Company Address		
Explain relationship with the firm and indicate percent ownership, if applicable (enter N/A, if not applicable):		
Are there any shareholders, directors, officers, owners, partners or proprietors that the submitting <b>Business Entity</b> has in common with this <b>affiliate</b> ?		Yes    No
Individual's Name	Position/Title with Firm/Company	
2.1 Does the <b>Business Entity</b> have any <b>construction</b> -related <b>affiliates</b> not identified in the response to 2.0 above?		Yes    No
Affiliate Name	Affiliate EIN (If available)	Affiliate's Primary Business Activity
Affiliate Address		
Explain relationship with the affiliate and indicate percent ownership, if applicable (enter N/A, if not applicable):		
Are there any shareholders, directors, officers, owners, partners or proprietors that the submitting <b>Business Entity</b> has in common with this firm?		Yes    No
Individual's Name	Position/Title with Firm/Company	
2.2 Has the <b>Business Entity</b> participated in any <b>construction Joint Ventures</b> within the past three (3) years? <i>Attach additional pages if necessary.</i>		Yes    No
Joint Venture Name	Joint Venture EIN (If available)	Identify parties to the Joint Venture

<b>III. CONTRACT HISTORY</b>
3.0 List the ten most recent <b>construction</b> contracts the <b>Business Entity</b> has completed using Attachment A – Completed Construction Contracts, found at <a href="http://www.osc.state.ny.us/vendrep/documents/attachmenta.doc">http://www.osc.state.ny.us/vendrep/documents/attachmenta.doc</a> . If less than ten, include most recent subcontracts on projects up to that number.
3.1 List all current uncompleted <b>construction</b> contracts by using Attachment B – Uncompleted Construction Contracts, found at <a href="http://www.osc.state.ny.us/vendrep/documents/attachmentb.doc">http://www.osc.state.ny.us/vendrep/documents/attachmentb.doc</a> .

<b>IV. INTEGRITY – CONTRACT BIDDING</b>		
Within the past five (5) years, has the Business Entity, an affiliate or any predecessor company or entity:		
4.0 Been <b>suspended</b> or <b>debarred</b> from any <b>government contracting process</b> or been <b>disqualified</b> on any government procurement?	Yes	No
4.1 Been subject to a denial or revocation of a government prequalification?	Yes	No
4.2 Had any bid rejected by a <b>government entity</b> for lack of qualifications, responsibility or because of the submission of an informal, non-responsive or incomplete bid?	Yes	No
4.3 Had a proposed subcontract rejected by a <b>government entity</b> for lack of qualifications, responsibility or because of the submission of an informal, non-responsive or incomplete bid?	Yes	No
4.4 Had a low bid rejected on a <b>government contract</b> for failure to make <b>good faith efforts</b> on any <b>Minority-Owned Business Enterprise, Women-Owned Business Enterprise or Disadvantaged Business Enterprise</b> goal or <b>statutory affirmative action requirements</b> on a previously held contract?	Yes	No



**NEW YORK STATE VENDOR RESPONSIBILITY QUESTIONNAIRE  
FOR PROFIT CONSTRUCTION (CCA-2)**

EIN:

<b>IV. INTEGRITY – CONTRACT BIDDING</b>		
Within the past five (5) years, has the Business Entity, an affiliate or any predecessor company or entity:		
4.5 Agreed to a voluntary exclusion from bidding/contracting with a <u>government entity</u> ?	Yes	No
4.6 Initiated a request to withdraw a bid submitted to a <u>government entity</u> or made any claim of an error on a bid submitted to a <u>government entity</u> ?	Yes	No
<i>For each “Yes,” provide an explanation of the issue(s), the <u>Business Entity</u> involved, the relationship to the submitting <u>Business Entity</u>, the <u>government entity</u> involved, project(s), relevant dates, any remedial or corrective action(s) taken and the current status of the issue(s). Provide answer(s) below or attach additional sheets with numbered responses.</i>		

<b>V. INTEGRITY – CONTRACT AWARD</b>		
Within the past five (5) years, has the Business Entity, an affiliate, or any predecessor company or entity:		
5.0 Defaulted on or been <u>suspended</u> , cancelled or <u>terminated for cause</u> on any contract?	Yes	No
5.1 Been subject to an <u>administrative proceeding</u> or civil action seeking specific performance or restitution (except any disputed work proceeding) or requiring the <u>Business Entity</u> to enter into a formal monitoring agreement in connection with any <u>government contract</u> ?	Yes	No
5.2 Had its surety called upon to complete any contract whether government or private sector?	Yes	No
<i>For each “Yes,” provide an explanation of the issue(s), the <u>Business Entity</u> involved, the relationship to the submitting <u>Business Entity</u>, the <u>government entity</u>/owners involved, project(s), contract number(s), relevant dates, any remedial or corrective action(s) taken and the current status of the issue(s). Provide answer(s) below or attach additional sheets with numbered responses.</i>		

<b>VI. CERTIFICATIONS/LICENSES</b>		
Within the past five (5) years, has the Business Entity, an affiliate, or any predecessor company or entity:		
6.0 Had a revocation or <u>suspension</u> of any business or professional permit and/or license?	Yes	No
6.1 Had a denial, decertification, revocation or forfeiture of New York State certification of <u>Minority-Owned Business Enterprise</u> , <u>Women-Owned Business Enterprise</u> or a <u>federal</u> certification of <u>Disadvantaged Business Enterprise</u> status, for other than a change of ownership?	Yes	No
<i>For each “Yes,” provide an explanation of the issue(s), the <u>Business Entity</u> involved, the relationship to the submitting <u>Business Entity</u>, the <u>government entity</u> involved, relevant dates, any remedial or corrective action(s) taken and the current status of the issue(s). Provide answer(s) below or attach additional sheets with numbered responses.</i>		

<b>VII. LEGAL PROCEEDINGS</b>		
Within the past five (5) years, has the Business Entity, an affiliate, or any predecessor company or entity:		
7.0 Been the subject of a criminal <u>investigation</u> , whether open or closed, or an indictment for any business-related conduct constituting a crime under local, state or <u>federal</u> law?	Yes	No
7.1 Been the subject of: (i) An indictment, grant of immunity, <u>judgment</u> or conviction (including entering into a plea bargain) for conduct constituting a crime; or (ii) Any criminal <u>investigation</u> , felony indictment or conviction concerning the formation of, or any business association with, an allegedly false or fraudulent <u>Minority-Owned Business Enterprise</u> , <u>Women-Owned Business Enterprise</u> , or a <u>Disadvantaged Business Enterprise</u> ?	Yes	No
7.2 Received any OSHA citation and Notification of Penalty containing a violation classified as <u>serious</u> or <u>willful</u> ?	Yes	No

**NEW YORK STATE VENDOR RESPONSIBILITY QUESTIONNAIRE  
FOR PROFIT CONSTRUCTION (CCA-2)**

EIN:

<b>VII. LEGAL PROCEEDINGS</b>		
Within the past five (5) years, has the Business Entity, an affiliate, or any predecessor company or entity:		
7.3 Had a <u>government entity</u> find a willful prevailing wage or supplemental payment violation?	Yes	No
7.4 Had a New York State Labor Law violation deemed willful?	Yes	No
7.5 Entered into a consent order with the New York State Department of Environmental Conservation, or a <u>federal</u> , state or local government enforcement determination involving a violation of <u>federal</u> , state or local environmental laws?	Yes	No
7.6 Other than previously disclosed, been the subject of any <u>citations, notices, violation orders</u> , pending administrative hearings or proceedings or determinations of a violation of:		
▪ <u>Federal</u> , state or local health laws, rules or regulations;	Yes	No
▪ <u>Federal</u> , state or local environmental laws, rules or regulations;	Yes	No
▪ Unemployment insurance or workers compensation coverage or <u>claim</u> requirements;	Yes	No
▪ Any labor law or regulation, which was deemed willful;	Yes	No
▪ Employee Retirement Income Security Act (ERISA);	Yes	No
▪ <u>Federal</u> , state or local human rights laws;	Yes	No
▪ <u>Federal</u> , state or local security laws?	Yes	No
<i>For each "Yes," provide an explanation of the issue(s), the <u>Business Entity</u> involved, the relationship to the submitting <u>Business Entity</u>, the <u>government entity</u> involved, relevant dates, any remedial or corrective action(s) taken and the current status of the issue(s). Provide answer(s) below or attach additional sheets with numbered responses.</i>		

<b>VIII. LEADERSHIP INTEGRITY</b>		
If the Business Entity is a Joint Venture Entity, answer "N/A - Not Applicable" to questions in this section.		
Within the past five (5) years has any individual previously identified or any individual having the authority to sign, execute or approve bids, proposals, contracts or supporting documentation on behalf of the Business Entity with New York State been subject to:		
8.0 A <u>sanction</u> imposed relative to any business or professional permit and/or license?	Yes N/A	No
8.1 A criminal <u>investigation</u> , whether open or closed, or an indictment for any business-related conduct constituting a crime under local, state or <u>federal</u> law?	Yes N/A	No
8.2 Misdemeanor or felony charge, indictment or conviction for:		
(i) Any business-related activity including but not limited to fraud, coercion, extortion, bribe or bribe-receiving, giving or accepting unlawful gratuities, immigration or tax fraud, racketeering, mail fraud, wire fraud, price-fixing or collusive bidding; or	Yes N/A	No
(ii) Any crime, whether or not business-related, the underlying conduct of which related to truthfulness, including but not limited to the filing of false documents or false sworn statements, perjury or larceny?	Yes N/A	No
8.3 A <u>debarment</u> from any <u>government contracting process</u> ?	Yes N/A	No
<i>For each "Yes," provide an explanation of the issue(s), the individual involved, the relationship to the submitting <u>Business Entity</u>, the <u>government entity</u> involved, relevant dates, any remedial or corrective action(s) taken and the current status of the issue(s). Provide answer(s) below or attach additional sheets with numbered responses.</i>		

**NEW YORK STATE VENDOR RESPONSIBILITY QUESTIONNAIRE  
FOR PROFIT CONSTRUCTION (CCA-2)**

EIN:

IX. FINANCIAL AND ORGANIZATIONAL CAPACITY		
9.0 Within the past five (5) years, has the <u>Business Entity</u> or any <u>affiliate</u> received any <u>formal unsatisfactory performance assessment(s)</u> from any <u>government entity</u> on any contract?		Yes    No
<i>If "Yes," provide an explanation of the issue(s), the <u>Business Entity</u> involved, the relationship to the submitting <u>Business Entity</u>, the <u>government entity</u> involved, relevant dates, any remedial or corrective action(s) taken and the current status of the issue(s). Provide answer below or attach additional sheets with numbered responses.</i>		
9.1 Within the past five (5) years, has the <u>Business Entity</u> or any <u>affiliate</u> had any <u>liquidated damages</u> assessed over \$25,000?		Yes    No
<i>If "Yes," provide an explanation of the issue(s), the <u>Business Entity</u> involved, the relationship to the submitting <u>Business Entity</u>, relevant dates, the contracting party involved, the amount assessed and the current status of the issue(s). Provide answer below or attach additional sheets with numbered responses.</i>		
9.2 Within the past five (5) years, has the <u>Business Entity</u> or any <u>affiliate</u> had any <u>liens, claims or judgments</u> (not including UCC filings) over \$25,000 filed against the <u>Business Entity</u> which remain undischarged or were unsatisfied for more than 90 days?		Yes    No
<i>If "Yes," provide an explanation of the issue(s), the <u>Business Entity</u> involved, the relationship to the submitting <u>Business Entity</u>, relevant dates, the Lien holder or Claimants' name(s), the amount of the <u>lien(s)</u> and the current status of the issue(s). Provide answer below or attach additional sheets with numbered responses.</i>		
9.3 In the last seven (7) years, has the <u>Business Entity</u> or any <u>affiliate</u> initiated or been the subject of any bankruptcy proceedings, whether or not closed, or is any bankruptcy proceeding pending?		Yes    No
<i>If "Yes," provide the <u>Business Entity</u> involved, the relationship to the submitting <u>Business Entity</u>, the bankruptcy chapter number, the court name and the docket number. Indicate the current status of the proceedings as "Initiated," "Pending" or "Closed." Provide answer below or attach additional sheets with numbered responses.</i>		
9.4 What is the <u>Business Entity's</u> Bonding Capacity?		
a. Single Project		b. Aggregate (All Projects)
9.5 List <u>Business Entity's</u> Gross Sales for the previous three (3) Fiscal Years:		
1st Year (Indicate year ) Gross Sales	2nd Year (Indicate year ) Gross Sales	3rd Year (Indicate year ) Gross Sales
9.6 List <u>Business Entity's</u> Average Backlog for the previous three (3) fiscal years: (Estimated total value of uncompleted work on outstanding contracts)		
1st Year (Indicate year ) Amount	2nd Year (Indicate year ) Amount	3rd Year (Indicate year ) Amount
9.7 Attach <u>Business Entity's</u> annual <u>financial statement</u> and accompanying notes or complete Attachment C – Financial Information, found at <a href="http://www.osc.state.ny.us/vendrep/documents/attachmentc.xls">http://www.osc.state.ny.us/vendrep/documents/attachmentc.xls</a>		
X. FREEDOM OF INFORMATION LAW (FOIL)		
10.0 Indicate whether any information provided herein is believed to be exempt from disclosure under the Freedom of Information Law (FOIL). <i>Note: A determination of whether such information is exempt from FOIL will be made at the time of any request for disclosure under FOIL. Attach additional pages if necessary.</i>		Yes    No
<i>Indicate the question number(s) and explain the basis for the claim.</i>		

**NEW YORK STATE VENDOR RESPONSIBILITY QUESTIONNAIRE  
FOR PROFIT CONSTRUCTION (CCA-2)**

**EIN:**

**Certification**

The undersigned: (1) recognizes that this questionnaire is submitted for the express purpose of assisting New York State contracting entities in making responsibility determinations regarding an award of a contract or approval of a subcontract; (2) recognizes that the Office of the State Comptroller (OSC) will rely on information disclosed in the questionnaire in making responsibility determinations and in approving a contract or subcontract; (3) acknowledges that the New York State contracting entities and OSC may, in their discretion, by means which they may choose, verify the truth and accuracy of all statements made herein; and (4) acknowledges that intentional submission of false or misleading information may constitute a misdemeanor or felony under New York State Penal Law, may be punishable by a fine and/or imprisonment under Federal Law, and may result in a finding of non-responsibility, contract suspension or contract termination.

The undersigned certifies that he/she:

- is knowledgeable about the submitting Business Entity's business and operations;
- has read and understands all of the questions contained in the questionnaire;
- has not altered the content of the questionnaire in any manner;
- has reviewed and/or supplied full and complete responses to each question;
- to the best of his/her knowledge, information and belief, confirms that the Business Entity's responses are true, accurate and complete, including all attachments, if applicable;
- understands that New York State will rely on the information disclosed in the questionnaire when entering into a contract with the Business Entity; and
- is under obligation to update the information provided herein to include any material changes to the Business Entity's responses at the time of bid/proposal submission through the contract award notification, and may be required to update the information at the request of the New York State contracting entities or OSC prior to the award and/or approval of a contract, or during the term of the contract.

Signature of Owner/Officer \_\_\_\_\_

Printed Name of Signatory \_\_\_\_\_

Title \_\_\_\_\_

Name of Business \_\_\_\_\_

Address \_\_\_\_\_

City, State, Zip \_\_\_\_\_

Sworn to before me this \_\_\_\_\_ day of \_\_\_\_\_, 20\_\_\_\_;

\_\_\_\_\_ Notary Public

**NEW YORK STATE VENDOR RESPONSIBILITY QUESTIONNAIRE  
ATTACHMENT A - COMPLETED CONSTRUCTION CONTRACTS**

EIN:

<b>Question 3.0: List the ten most recent construction contracts the Business Entity has completed. If less than ten, include most recent subcontractson projects up to that number.</b>						
1.	<b>Agency/Owner</b>			<b>Award Date</b>	<b>Amount</b>	<b>Date Completed</b>
	<b>Contact Person</b>		<b>Telephone No.</b>	<b>Design Architect and/or Design Engineer</b>		
	<b>Contract No.</b>	<b>Prime or Sub</b>	<b>Joint Venture (JV) Name, if applicable</b>		<b>EIN of JV, if applicable</b>	
2.	<b>Agency/Owner</b>			<b>Award Date</b>	<b>Amount</b>	<b>Date Completed</b>
	<b>Contact Person</b>		<b>Telephone No.</b>	<b>Design Architect and/or Design Engineer</b>		
	<b>Contract No.</b>	<b>Prime or Sub</b>	<b>Joint Venture (JV) Name, if applicable</b>		<b>EIN of JV, if applicable</b>	
3.	<b>Agency/Owner</b>			<b>Award Date</b>	<b>Amount</b>	<b>Date Completed</b>
	<b>Contact Person</b>		<b>Telephone No.</b>	<b>Design Architect and/or Design Engineer</b>		
	<b>Contract No.</b>	<b>Prime or Sub</b>	<b>Joint Venture (JV) Name, if applicable</b>		<b>EIN of JV, if applicable</b>	
4.	<b>Agency/Owner</b>			<b>Award Date</b>	<b>Amount</b>	<b>Date Completed</b>
	<b>Contact Person</b>		<b>Telephone No.</b>	<b>Design Architect and/or Design Engineer</b>		
	<b>Contract No.</b>	<b>Prime or Sub</b>	<b>Joint Venture (JV) Name, if applicable</b>		<b>EIN of JV, if applicable</b>	
5.	<b>Agency/Owner</b>			<b>Award Date</b>	<b>Amount</b>	<b>Date Completed</b>
	<b>Contact Person</b>		<b>Telephone No.</b>	<b>Design Architect and/or Design Engineer</b>		
	<b>Contract No.</b>	<b>Prime or Sub</b>	<b>Joint Venture (JV) Name, if applicable</b>		<b>EIN of JV, if applicable</b>	

**NEW YORK STATE VENDOR RESPONSIBILITY QUESTIONNAIRE  
ATTACHMENT A - COMPLETED CONSTRUCTION CONTRACTS**

EIN:

<b>Question 3.0: List the ten most recent construction contracts the Business Entity has completed. If less than ten, include most recent subcontracts on projects up to that number.</b>						
6.	<b>Agency/Owner</b>			<b>Award Date</b>	<b>Amount</b>	<b>Date Completed</b>
	<b>Contact Person</b>		<b>Telephone No.</b>	<b>Design Architect and/or Design Engineer</b>		
	<b>Contract No.</b>	<b>Prime or Sub</b>	<b>Joint Venture (JV) Name, if applicable</b>		<b>EIN of JV, if applicable</b>	
7.	<b>Agency/Owner</b>			<b>Award Date</b>	<b>Amount</b>	<b>Date Completed</b>
	<b>Contact Person</b>		<b>Telephone No.</b>	<b>Design Architect and/or Design Engineer</b>		
	<b>Contract No.</b>	<b>Prime or Sub</b>	<b>Joint Venture (JV) Name, if applicable</b>		<b>EIN of JV, if applicable</b>	
8.	<b>Agency/Owner</b>			<b>Award Date</b>	<b>Amount</b>	<b>Date Completed</b>
	<b>Contact Person</b>		<b>Telephone No.</b>	<b>Design Architect and/or Design Engineer</b>		
	<b>Contract No.</b>	<b>Prime or Sub</b>	<b>Joint Venture (JV) Name, if applicable</b>		<b>EIN of JV, if applicable</b>	
9.	<b>Agency/Owner</b>			<b>Award Date</b>	<b>Amount</b>	<b>Date Completed</b>
	<b>Contact Person</b>		<b>Telephone No.</b>	<b>Design Architect and/or Design Engineer</b>		
	<b>Contract No.</b>	<b>Prime or Sub</b>	<b>Joint Venture (JV) Name, if applicable</b>		<b>EIN of JV, if applicable</b>	
10.	<b>Agency/Owner</b>			<b>Award Date</b>	<b>Amount</b>	<b>Date Completed</b>
	<b>Contact Person</b>		<b>Telephone No.</b>	<b>Design Architect and/or Design Engineer</b>		
	<b>Contract No.</b>	<b>Prime or Sub</b>	<b>Joint Venture (JV) Name, if applicable</b>		<b>EIN of JV, if applicable</b>	

**NEW YORK STATE VENDOR RESPONSIBILITY QUESTIONNAIRE  
ATTACHMENT B - UNCOMPLETED CONSTRUCTION CONTRACTS**

EIN:

<b>Question 3.1: List all current uncompleted construction contracts.</b>								
1.	<b>Agency/Owner</b>					<b>Award Date</b>	<b>Amount</b>	<b>Date Completed</b>
	<b>Contact Person</b>			<b>Telephone No.</b>	<b>Design Architect and/or Design Engineer</b>			
	<b>Contract No.</b>	<b>Prime or Sub</b>	<b>Joint Venture (JV) Name, if applicable</b>				<b>EIN of JV, if applicable</b>	
				<b>Total Contract Amount</b>	<b>Amount Sublet to Others</b>	<b>Uncompleted Amount</b>		
2.	<b>Agency/Owner</b>					<b>Award Date</b>	<b>Amount</b>	<b>Date Completed</b>
	<b>Contact Person</b>			<b>Telephone No.</b>	<b>Design Architect and/or Design Engineer</b>			
	<b>Contract No.</b>	<b>Prime or Sub</b>	<b>Joint Venture (JV) Name, if applicable</b>				<b>EIN of JV, if applicable</b>	
				<b>Total Contract Amount</b>	<b>Amount Sublet to Others</b>	<b>Uncompleted Amount</b>		
3.	<b>Agency/Owner</b>					<b>Award Date</b>	<b>Amount</b>	<b>Date Completed</b>
	<b>Contact Person</b>			<b>Telephone No.</b>	<b>Design Architect and/or Design Engineer</b>			
	<b>Contract No.</b>	<b>Prime or Sub</b>	<b>Joint Venture (JV) Name, if applicable</b>				<b>EIN of JV, if applicable</b>	
				<b>Total Contract Amount</b>	<b>Amount Sublet to Others</b>	<b>Uncompleted Amount</b>		
4.	<b>Agency/Owner</b>					<b>Award Date</b>	<b>Amount</b>	<b>Date Completed</b>
	<b>Contact Person</b>			<b>Telephone No.</b>	<b>Design Architect and/or Design Engineer</b>			
	<b>Contract No.</b>	<b>Prime or Sub</b>	<b>Joint Venture (JV) Name, if applicable</b>				<b>EIN of JV, if applicable</b>	
				<b>Total Contract Amount</b>	<b>Amount Sublet to Others</b>	<b>Uncompleted Amount</b>		

**NEW YORK STATE VENDOR RESPONSIBILITY QUESTIONNAIRE  
ATTACHMENT B - UNCOMPLETED CONSTRUCTION CONTRACTS**

EIN:

<b>Question 3.1: List all current uncompleted construction contracts.</b>								
5.	<b>Agency/Owner</b>				<b>Award Date</b>	<b>Amount</b>	<b>Date Completed</b>	
	<b>Contact Person</b>			<b>Telephone No.</b>	<b>Design Architect and/or Design Engineer</b>			
	<b>Contract No.</b>	<b>Prime or Sub</b>	<b>Joint Venture (JV) Name, if applicable</b>				<b>EIN of JV, if applicable</b>	
				<b>Total Contract Amount</b>	<b>Amount Sublet to Others</b>	<b>Uncompleted Amount</b>		
6.	<b>Agency/Owner</b>				<b>Award Date</b>	<b>Amount</b>	<b>Date Completed</b>	
	<b>Contact Person</b>			<b>Telephone No.</b>	<b>Design Architect and/or Design Engineer</b>			
	<b>Contract No.</b>	<b>Prime or Sub</b>	<b>Joint Venture (JV) Name, if applicable</b>				<b>EIN of JV, if applicable</b>	
				<b>Total Contract Amount</b>	<b>Amount Sublet to Others</b>	<b>Uncompleted Amount</b>		
7.	<b>Agency/Owner</b>				<b>Award Date</b>	<b>Amount</b>	<b>Date Completed</b>	
	<b>Contact Person</b>			<b>Telephone No.</b>	<b>Design Architect and/or Design Engineer</b>			
	<b>Contract No.</b>	<b>Prime or Sub</b>	<b>Joint Venture (JV) Name, if applicable</b>				<b>EIN of JV, if applicable</b>	
				<b>Total Contract Amount</b>	<b>Amount Sublet to Others</b>	<b>Uncompleted Amount</b>		
8.	<b>Agency/Owner</b>				<b>Award Date</b>	<b>Amount</b>	<b>Date Completed</b>	
	<b>Contact Person</b>			<b>Telephone No.</b>	<b>Design Architect and/or Design Engineer</b>			
	<b>Contract No.</b>	<b>Prime or Sub</b>	<b>Joint Venture (JV) Name, if applicable</b>				<b>EIN of JV, if applicable</b>	
				<b>Total Contract Amount</b>	<b>Amount Sublet to Others</b>	<b>Uncompleted Amount</b>		



**NEW YORK STATE VENDOR RESPONSIBILITY QUESTIONNAIRE  
ATTACHMENT B - UNCOMPLETED CONSTRUCTION CONTRACTS**

EIN:

<b>Question 3.1: List all current uncompleted construction contracts.</b>							
9.	<b>Agency/Owner</b>				<b>Award Date</b>	<b>Amount</b>	<b>Date Completed</b>
	<b>Contact Person</b>		<b>Telephone No.</b>	<b>Design Architect and/or Design Engineer</b>			
	<b>Contract No.</b>	<b>Prime or Sub</b>	<b>Joint Venture (JV) Name, if applicable</b>			<b>EIN of JV, if applicable</b>	
				<b>Total Contract Amount</b>	<b>Amount Sublet to Others</b>	<b>Uncompleted Amount</b>	
10.	<b>Agency/Owner</b>				<b>Award Date</b>	<b>Amount</b>	<b>Date Completed</b>
	<b>Contact Person</b>		<b>Telephone No.</b>	<b>Design Architect and/or Design Engineer</b>			
	<b>Contract No.</b>	<b>Prime or Sub</b>	<b>Joint Venture (JV) Name, if applicable</b>			<b>EIN of JV, if applicable</b>	
				<b>Total Contract Amount</b>	<b>Amount Sublet to Others</b>	<b>Uncompleted Amount</b>	
<b>Grand Total All Uncompleted Contracts</b>							

**NEW YORK STATE VENDOR RESPONSIBILITY QUESTIONNAIRE  
ATTACHMENT C – FINANCIAL INFORMATION**

**EIN:  
As of Date:**

**ASSETS**

Current Assets

1.	<u>Cash</u>		\$	
2.	<u>Accounts receivable – less allowance for doubtful accounts</u>	\$		
	Retainers included in accounts receivable			
	Claims included in accounts receivable not yet approved or in litigation			
	Total accounts receivable		\$	
3.	<u>Notes receivable – due within one year</u>		\$	
4.	<u>Inventory – materials</u>		\$	
5.	<u>Contract costs in excess of billings on uncompleted contracts</u>		\$	
6.	<u>Accrued income receivable</u>			
	Interest			
	Other (list)			
	Total accrued income receivable		\$	
7.	<u>Deposits</u>			
	Bid and plan			
	Other (list)			
	Total deposits		\$	
8.	<u>Prepaid expenses</u>			
	Income Taxes			
	Insurance			
	Other (List)			
	Total prepaid expenses		\$	
9.	<u>Other current assets</u>			
	(List)			
	Total other current assets		\$	
10.	<u>Total current assets</u>			\$

**NEW YORK STATE VENDOR RESPONSIBILITY QUESTIONNAIRE  
ATTACHMENT C – FINANCIAL INFORMATION**

**EIN:**

11.	<u>Investments</u>			
	Listed securities present market value	\$		
	Unlisted securities present value			
	Total investments		\$	
12.	<u>Fixed Assets</u>			
	Land			
	Building and improvements			
	Leasehold improvements			
	Machinery and equipment			
	Automotive equipment			
	Office furniture and fixtures			
	Other (list)			
	Total		\$	
	Less: accumulated depreciation		\$	
	Total fixed assets net			\$
13.	<u>Other Assets</u>			
	Loans receivable	officers		
		employees		
		shareholders		
	Cash surrender value of officers' life insurance			
	Organization expense – net of amortization			
	Notes receivable – due after one year			
	Other (list)			
	Total Other Assets		\$	
14.	<u>TOTAL ASSETS</u>			\$

**NEW YORK STATE VENDOR RESPONSIBILITY QUESTIONNAIRE  
ATTACHMENT C – FINANCIAL INFORMATION**

**EIN:**

**LIABILITIES**

Current Liabilities

15.	Accounts payable		\$
16.	Loans from shareholders – due within one year		
17.	Notes payable – due within one year		
18.	Mortgage payable – due within one year		
19.	Other payables – due within one year (List)	\$	
	Total other payables – due within one year		
20.	Billings in excess of costs and estimated earnings		
21.	Accrued expenses payable	Salaries and wages Employees' benefits Insurance Other	
	Total accrued expenses payable		
22.	Dividends payable		
23.	Income taxes payable	State Federal Other	
	Total income taxes payable		
24.	Total Current Liabilities		\$
25.	Deferred Income Taxes Payable	State Federal Other	
	Total deferred income taxes		\$

**NEW YORK STATE VENDOR RESPONSIBILITY QUESTIONNAIRE  
ATTACHMENT C – FINANCIAL INFORMATION**

**EIN:**

26.	<u>Long Term Liabilities</u> Loans from shareholders – due after one year Notes payable – due after one year Mortgage – due after one year Other payables – due after one year (List)		
	Total long term liabilities	\$	
27.	<u>Other Liabilities</u> (List)		
	Total other liabilities	\$	
28.	<u>TOTAL LIABILITIES</u>		\$
	<b><u>NET WORTH</u></b>		
29.	Net Worth (if proprietorship or partnership)	\$	
30.	Stockholders' Equity		
	Common stock issued and outstanding	\$	
	Preferred stock issued and outstanding		
	Retained earnings		
	Total	\$	
	Less: Treasury Stock		
31.	<b>TOTAL STOCKHOLDERS EQUITY</b>		\$
32.	<b>TOTAL LIABILITIES AND STOCKHOLDERS' EQUITY</b>		\$

## AGREEMENT BETWEEN OWNER AND CONTRACTOR

This AGREEMENT made on the \_\_\_ day of \_\_\_\_\_ in the year \_\_\_\_ by and between, **City of Rome , NY** (hereinafter called OWNER) and \_\_\_\_\_ (hereinafter called the CONTRACTOR).

OWNER and CONTRACTOR, in consideration of the mutual covenants hereinafter set forth, agree as follows:

### ARTICLE 1 – WORK

The Contractor shall complete all Work as specified or indicated in the Contract Documents. The Work is generally described as follows:

*This project is a pedestrian and bicycle improvement project located on the northern side of Erie Blvd, between S. George St. and S. James St. The project includes removing the existing access road and installing pedestrian and bicycle facilities including sidewalks, a cycle track, a shared use path, and other amenities. The median island will be renovated and resized to include a new median wall, tree plantings, and mid-block crossing. Additional project elements include upgraded pedestrian crossings with new push buttons and pedestrian signals, new ADA curb ramps, pedestrian refuge islands, and RRFB mid-block crossing, driveway delineations, improved signage and landscaping.*

### ARTICLE 2 – ENGINEER

The Project has been designed by Greenman-Pedersen, Inc who is hereinafter called ENGINEER and who is to act as OWNERS representative, assume all duties and responsibilities and have the rights and authority assigned to ENGINEER in the Contract Documents in connection with completion of the Work in accordance with the Contract Documents.

### ARTICLE 3 - CONTRACT TIME

**3.1.** The Work will be completed **150** calendar days from the Notice to Proceed and completed and ready for final payment on **8/29/2025**.

**3.2.** Liquidated Damages. OWNER and CONTRACTOR recognize that time is of the essence of this Agreement and that the OWNER will suffer financial loss if the Work is not completed within the times specified in paragraph 3.1 above, plus any extensions thereof allowed. They also recognize delays, expense and difficulties involved in proving the actual loss suffered by the OWNER is not completed on time. Accordingly, instead of requiring such proof, OWNER and CONTRACTOR agree that as liquidated damages for delay (but not as a penalty) CONTRACTOR shall pay OWNER Liquidated Damages assessed in accordance with the current NYSDOT Standard Specifications, Section 108-03 and/or Table 108-1 “Schedule of Liquidated Damages” included below. If Section 108-03 and/or Table 108-1 are amended during the project, the amended provision shall control. The Reference to the “Commissioner of Transportation” shall be read to mean OWNER.

Table 108-1 - SCHEDULE OF LIQUIDATED DAMAGES		
Original Total Contract Bid Price		Liquidated Damages per Calendar Day
From More Than	To and Including	
\$0	\$100,000	\$500
\$100,000	\$500,000	\$1,000
\$500,000	\$2,000,000	\$1,500
\$2,000,000	\$5,000,000	\$2,000
\$5,000,000	\$10,000,000	\$2,500
\$10,000,000	\$20,000,000	\$4,000
\$20,000,000	-	\$7,000

**ARTICLE 4 - CONTRACT PRICE**

OWNER shall pay CONTRACTOR an amount in current funds equal to the sum of the amounts determined pursuant to paragraphs 4.1 and 4.2 below for completion of Work in accordance with the Contract Documents:

4.1. For lump sum items, payment will be based on the price bid and made in accordance with the specification. For all Unit Price items, the payment will be made based upon the bid unit price, for each separately identified unit price item, multiplied by the estimated quantity of that item as indicated in the Bid Summary Forms.

TOTAL OF ALL  
UNIT PRICES \_\_\_\_\_ \$ \_\_\_\_\_ dollars  
*(Use words)* *(figures)*

4.2. Estimated quantities are not guaranteed, and determinations of actual quantities and classifications are to be made by ENGINEER.

**ARTICLE 5 – PAYMENTS**

5.1. OWNER shall make progress payments on account of the Contract Price on the basis of CONTRACTOR’s Applications for Payment as recommended by the ENGINEER, on or about the 10th day of each month during construction as provided in paragraphs 5.1.1 and 5.1.2 below. All such payments will be measured by the number of units completed.

5.1.1. As the work progresses in accordance with the contract and in a manner that is satisfactory to the Owner, the Owner hereby agrees to make payments to the Contractor therefore, based upon the proposal attached hereto and made a part hereof, as follows: The Owner shall once in each month and on such days as it may fix, determine the quantity of work completed and of material which has actually been put in place in accordance with the terms and conditions of the contract, during the preceding month, and compute the value thereof and pay to the Contractor the monies due as determined by the Engineer. No monthly payment shall be rendered unless the value of the work completed equals 5% of the contract amount or \$1,000, whichever is the lesser. Semi-monthly payments may be rendered provided (a) the value of work performed in two successive weeks is more than \$50,000 or (b) the Engineer deems it to be on the best interest of the Owner to do so. The Contractor shall not hold any retainage from any Subcontractor.

5.1.2. When in the opinion of the Engineer, a Contractor has fully performed the work under the contract, the Engineer shall recommend to the Owner the acceptance of work so completed. If the Owner accepts the recommendation of the Engineer, he/she shall thereupon by letter notify the Contractor, with copies to the other interested parties, of such acceptance. Prior to the final acceptance of the work by the Owner, the contract work may be inspected, accepted and approved by other agencies and/or municipalities who will have jurisdiction of the work after final acceptance.

5.2. The final payment shall be made upon final completion and acceptance of the work by the Owner and as recommended by the Engineer.

**ARTICLE 6 - INTEREST**

All monies not paid when due shall bear interest at the statutory rate of New York State.

## **ARTICLE 7 - CONTRACTOR REPRESENTATIONS.**

In order to induce the OWNER to enter into this Agreement the CONTRACTOR makes the following representations:

- 7.1 CONTRACTOR has examined and carefully studied the Contract Documents (including Addenda listed in Article 8) and other related data identified in the Bidding Documents including “technical data.”
- 7.2 CONTRACTOR has visited the site and become familiar with and is satisfied as to the general, local, and site conditions that may affect cost, progress, performance or furnishing of the Work.
- 7.3 CONTRACTOR is familiar with and will comply with all federal, state and local Laws and Regulations that may affect, progress, performance and furnishing of the Work.
- 7.4 CONTRACTOR has carefully studied all reports of explorations and tests of subsurface conditions at or contiguous to the site and all drawings of physical conditions in or relating to existing surface or subsurface structures at or contiguous to the site (except Underground Facilities). CONTRACTOR acknowledges that such reports and drawings are not Contract Documents and may not be complete for CONTRACTOR’S purposes. CONTRACTOR acknowledges that OWNER and ENGINEER do not assume responsibility for the accuracy or completeness of information and data shown or indicated in the Contract Documents with respect to Underground Facilities at or contiguous to the site. CONTRACTOR has obtained and carefully studied (or assumes responsibility for having done so) all such additional supplementary examinations, investigations, explorations test, studies and data concerning conditions (surface, subsurface, Underground Facilities) at or contiguous to the site or otherwise which may affect the cost, progress, performance, or furnishing of the Work or which relate to any aspect of the means, methods, techniques, sequences, and procedures of construction to be employed by CONTRACTOR and safety precautions, and programs incident thereto. CONTRACTOR does not consider that any additional examinations, investigations, explorations, test, studies, or data are necessary for the performance and furnishing of the Work at the Contract Price, within the Contract Times and in accordance with the other terms and conditions of the Contract Documents.
- 7.5 CONTRACTOR is aware of the general nature of the work to be performed by OWNER and others at the site that relates to the Work as indicated in the Contract Documents.
- 7.6 CONTRACTOR has correlated the information known to the CONTRACTOR, information and observation obtained from visits to the site, reports, and drawings identified in the Contract Documents and all additional examinations, investigations, explorations, tests, studies, and data with the Contract Documents.
- 7.7 CONTRACTOR has given ENGINEER written notice of all conflicts, errors, ambiguities or discrepancies that CONTRACTOR has discovered in the Contract Documents and the written resolution thereof by ENGINEER is acceptable to the CONTRACTOR, and the Contract Documents are generally sufficient to indicate and convey understanding of all terms and conditions for performance and furnishing of the Work.

## **ARTICLE 8 - CONTRACT DOCUMENTS**

The Contract Documents which comprise the entire agreement between the Owner and the Contractor concerning the Work consist of the following:

- 8.1. This Agreement
- 8.2. Performance, Payment and other Bonds



- 8.3. Notice to Proceed
- 8.4. All technical specification as set forth in the Table of Contents
- 8.5. Drawings consisting of a cover sheet and sheets numbered 1 through 60, inclusive with each sheet bearing the following general title:  
**Downtown Rome Wheels to Heels Streetscapes**
- 8.6. Addenda numbers, inclusive
- 8.7. CONTRACTOR's Bid Pages as set forth in the Bidders Checklist
- 8.8. Documentation submitted by CONTRACTOR prior to Notice of Award
- 8.9. Appendix A – Additional Provisions
- 8.10. State and/or Federal Prevailing Wage Schedules, as applicable
- 8.11. All other documents set forth in this project manual except Supplemental Information Available to Bidders
- 8.12. The following which may be delivered or issued after the Effective Date of the Agreement and are not attached hereto: All written Amendments and other documents amending, modifying or supplementing the Contract Documents.

## **ARTICLE 9 - MISCELLANEOUS.**

- 9.1. No assignment by a party hereto of any rights under or interests in the Contract Documents will be binding on another party hereto without the written consent of the party sought to be bound; and, specifically but without limitation, moneys that may become due and moneys that are due may not be assigned without such consent (except to the extent that the effect of this restriction may be limited by law), and unless specifically stated to the contrary in any written consent to an assignment no assignment will release or discharge the assignor from any duty or responsibility under the Contract Documents.
- 9.2. Neither the Owner nor the Contractor shall, without the prior written consent of the other, assign or sublet in whole or in part his interest under any of the Contract Documents and, specifically, the Contractor shall not assign any monies due or to become due without the prior written consent of the Owner.
- 9.3. The Owner and the Contractor each binds itself, its partners, successors, assigns and legal representatives to the other party hereto, its partners, successors, assigns and legal representatives in respect to all covenants, agreements and obligations contained in the Contract Documents.
- 9.4. Any provision or part of the Contract Documents held to be void or unenforceable under any Law or Regulation shall be deemed stricken, and all remaining provisions shall continue to be valid and binding upon OWNER and CONTRACTOR, who agree that the Contract Documents shall be reformed to replace such stricken provision or part thereof with a valid and unenforceable provision that comes as close as possible to expressing the intention of the stricken provision.
- 9.5. **OTHER PROVISIONS**  
IN WITNESS WHEREOF, OWNER and CONTRACTOR have signed this Agreement in triplicate. One counterpart each has been delivered to OWNER, CONTRACTOR and ENGINEER. All portions of the Contract Documents have been signed, initialed or identified by OWNER and CONTRACTOR, or identified by ENGINEER on their behalf.

**ARTICLE 10 - NEW YORK STATE ENVIRONMENTAL FACILITIES CORPORATION  
CONTRACT REQUIREMENTS**

**10.1 REQUIREMENTS REGARDING SUSPENSION AND DEBARMENT**

The requirements of this section apply to all Contracts and Subcontracts.  
 Contractor and any Subcontractors shall comply with, Subpart C of 2 CFR Part 180 as implemented and supplemented by 2 CFR Part 1532. The Contractor is not a debarred or suspended party under 2 CFR Part 180 or 2 CFR Part 1532, or 29 CFR § 5.12. Neither the Contractor nor any of its Subcontractors have contracted with, or will contract with, any debarred or suspended party under the foregoing regulations.  
 The Contractor and any Subcontractors have not been deemed ineligible to submit a bid on or be awarded a public contract or subcontract pursuant to Article 8 of the State Labor Law, specifically Labor Law § 220-b. In addition, neither the Contractor nor any Subcontractors have contracted with, or will contract with, any party that has been deemed ineligible to submit a bid on or be awarded a public contract or subcontract under Labor Law § 220-b.  
 In addition, the Contractor and any Subcontractors have not been deemed ineligible to submit a bid and have not contracted with and will not contract with any party that has been deemed ineligible to submit a bid under Executive Law § 316.

**10.2 RESTRICTIONS ON LOBBYING**

The requirements of this section apply to all Contracts and Subcontracts greater than \$100,000. Disregard this section if it does not apply to this Contract or Subcontract.  
 The Contractor and any Subcontractor executing a Contract or Subcontract in excess of \$100,000 agree to provide to the Recipient an executed Certification Regarding Lobbying pursuant to 40 CFR Part 34 (“Lobbying Certification”) in the form attached hereto as Attachment 9, consistent with the prescribed form provided in Appendix A to 40 CFR Part 34.

This Agreement will be effective on \_\_\_\_\_ 20\_\_\_\_ (which is the Effective Date of the Agreement).

OWNER \_\_\_\_\_  
 \_\_\_\_\_  
 By: \_\_\_\_\_

CONTRACTOR \_\_\_\_\_  
 \_\_\_\_\_  
 By: \_\_\_\_\_

[CORPORATE SEAL]

[CORPORATE SEAL]

Attest: \_\_\_\_\_  
 Address for giving notices  
 \_\_\_\_\_  
 \_\_\_\_\_

Attest: \_\_\_\_\_  
 Address for giving notices  
 \_\_\_\_\_  
 \_\_\_\_\_

(If OWNER is a public body, attached evidence of authority to sign and resolution or other documents authorizing execution of Agreement

License No. \_\_\_\_\_  
 Agent for services of process: \_\_\_\_\_  
 \_\_\_\_\_  
 \_\_\_\_\_

(If CONTRACTOR is a corporation, attach evidence of authority to sign).

ACKNOWLEDGMENT OF VILLAGE

*State of New York } ss  
County of Oneida } ss*

On this .....day of ....., 20..... before me, the undersigned, a Notary Public in and for said State, personally appeared \_\_\_\_\_, as Mayor of The City of Rome, New York, personally known to me or proved to me on the basis of satisfactory evidence to be the individual whose name is subscribed to the within instrument, and that said \_\_\_\_\_ duly acknowledged to me that he executed the same pursuant to the power and authority vested in them by the Common Council, and that by their signature on the instrument he/she executed the instrument pursuant to the authority vested in them.

.....  
Notary Public

ACKNOWLEDGMENT OF CONTRACTOR

*State of ..... } ss  
County of ..... } ss*

On this .....day of ....., 20....., before me, the undersigned, a Notary Public in and for said State personally came and appeared ....., personally known to me, or proved to me on the basis of satisfactory evidence to be the individual whose name is subscribed to the within instrument, who, being by me duly sworn, did depose and say that he / she resides at ..... and that he/ she is the

..... of .....  
.....  
the corporation described in and which executed the foregoing instrument; that he / she knows the seal of said corporation, that one of the seals affixed to said instrument is such seal; that it was so affixed by order of the directors of said corporation, and that he / she signed his / her name thereto by like order.

.....  
Notary Public

# CONSTRUCTION PAYMENT BOND

Any singular reference to Contractor, Surety, Owner, or other party shall be considered plural where applicable.

---

CONTRACTOR (Name and Address)

SURETY (Name and Principal Place of Business):

OWNER (Name and Address)

CONSTRUCTION CONTRACT

Date: \_\_\_\_\_ Amount: \_\_\_\_\_

Description (Name and Location):

BOND

Date (not earlier than Construction Contract Date): \_\_\_\_\_ Amount: \_\_\_\_\_

Modifications to this Bond Form:

CONTRACTOR AS PRINCIPAL

Company

(Corp Seal)

SURETY

Company

(Corp Seal)

Signature: \_\_\_\_\_ Signature: \_\_\_\_\_

Name and Title:

Name and Title:

---

CONTRACTOR AS PRINCIPAL

Company

(Corp Seal)

SURETY

Company

(Corp Seal)

Signature: \_\_\_\_\_ Signature: \_\_\_\_\_

Name and Title:

Name and Title:

1. The Contractor and the Surety, jointly and severally, bind themselves, their heirs, executors, administrators, successors, and assigns to the Owner to pay for labor, materials, and equipment furnished for use in the performance of the Construction Contract, which is incorporated herein by reference.
2. With respect to the Owner, this obligation shall be null and void if the Contractor:
  - 2.1 Promptly makes payment, directly or indirectly, for all sums due Claimants, and
  - 2.2 Defends, indemnifies and hold harmless the Owner from all claims, demands, liens or suits by any person or entity who furnished labor, materials, or equipment for use in the performance of the Construction Contract, provided the Owner has promptly notified the Contractor and the Surety (at the address described in Paragraph 12) of any claims, demands, liens or suits and tendered defense of such claims, demands liens or suits to the Contractor and the Surety, and provided there is not Owner Default.
3. With respect to Claimants, this obligation shall be null and void if the Contractor promptly makes payment, directly or indirectly, for all sums due.
4. The Surety shall have no obligation to Claimants under this Bond until:
  - 4.1 Claimants who are employed by or have a direct contract with the Contractor have given notice to the Surety (at the address described in Paragraph 12) and sent a copy, or notice thereof, to the Owner, stating that a claim is being made under this Bond and, with substantial accuracy, the amount of the claim.
  - 4.2 Claimants who do not have a direct contract with the Contractor:
    1. Have furnished written notice to the Contractor and sent a copy, or notice thereof, to the Owner, within 90 days after having last performed labor or last furnished materials or equipment included in the claim stating, with substantial accuracy, the amount of the claim and the name of the party to whom the materials were furnished or supplied or for whom the labor was done or performed; and
    2. Have either received a rejection in whole or in part from the Contractor, or not received within 30 days of furnishing the above notice any communication from the Contractor by which the Contractor has indicated the claim will be paid directly or indirectly; and
    3. Not having been paid within the above 30 days, have sent a written notice to the Surety (at the address described in Paragraph 12) and sent a copy, or notice thereof, to the Owner stating that a claim is being made under this Bond and enclosing a copy of the previous written notice furnished to the Contractor.
5. If a notice required by Paragraph 4 is given to the Contractor to the Surety, that is sufficient compliance.
6. When the Claimant has satisfied the conditions of Paragraph 4, the Surety shall promptly and at the Surety's expense take the following actions:
  - 6.1 Send an answer to the Claimant, with a copy to the Owner, within 45 days after receipt of the claim, stating the amounts that are undisputed and the basis for challenging any amounts that are disputed.
  - 6.2 Pay or arrange for payment of any undisputed amounts.
7. The Surety's total obligation shall not exceed the amount of this Bond, and the amount of this Bond shall be credited for any payments made in good faith by the Surety.
8. Amount owed by the Owner to the Contractor under the Construction Contract shall be used for the performance of the Construction Contract and to satisfy claims, if any, under any Construction Performance Bond. By the Contractor furnishing and the Owner accepting this Bond, they agree that all funds earned by the Contractor in the performance of the Construction Contract area dedicated to satisfy obligations of the Contractor and the Surety under this Bond, subject to the Owner's priority to use the funds for the completion of the work.
9. The Surety shall not be liable to the Owner, Claimants, or others for obligations of the Contractor that are unrelated to the Construction Contract. The Owner shall not be liable for payment of any costs or expenses of any claimant under this Bond, and shall have under this Bond no obligations to make payments to give notices on behalf of, or otherwise have obligations to make payments to, give notices on behalf of, or otherwise have obligations to Claimants under this Bond.
10. The Surety hereby waives notice of any change, including changes of time, to the Construction Contract or to related subcontracts, purchase orders and other obligations.
11. No suit or action shall be commenced by a Claimant under this Bond other than in a court of competent jurisdiction in the location in which the work or part of the work is located or after the expiration of one year from the date (1) on which the Claimant gave the notice required by Subparagraph 4.1 or Clause 4.2 (iii), or (2) on which the last labor or service was performed by anyone or the last materials or equipment were furnished by anyone under the Construction Contract, whichever of (1) or (2) first occurs. If the provisions of this Paragraph are void or prohibited by law, the minimum period of limitation available to sureties as a defense in the jurisdiction of the suit shall be applicable.
12. Notice to the Surety, the Owner or the Contractor shall be mailed or delivered to the address shown on the signature page. Actual receipt of notice by Surety, the Owner, or the Contractor, however accomplished, shall be sufficient compliance as of the date received at the address shown on the signature page.
13. When this bond has been furnished to comply with a statutory or other legal requirements in the location where the construction was to be performed, any provision in this Bond conflicting with said statutory or legal requirements shall be deemed deleted herefrom and provisions conforming to such statutory or other legal requirements shall be deemed incorporated herein. The intent is that this Bond shall be construed as a statutory bond and not as a common law bond.
14. Upon request by any person or entity appearing to be a potential beneficiary of this Bond, the Contractor shall promptly furnish a copy of this Bond or shall permit a copy to be made.
15. Definitions.
  - 15.1 Claimant: An individual or entity have a direct contract with the Contractor or with a subcontractor of the Contractor to furnish labor, materials, or equipment for use in the performance of the Contract. The intent of this Bond shall be to include without limitation in the terms "labor, materials, or equipment" that part of water, gas, power, light, heat, oil, gasoline, telephone service or rental equipment used in the Construction, architectural and engineering services required for performance of the work of the Contractor and the Contractor's subcontractors, and all other items for which a mechanic's lien may be asserted in the jurisdiction where the labor, materials, or equipment were furnished.
  - 15.2 Construction Contract: The agreement between the Owner and the Contractor identified on the signature page, including all Contract Documents and changes thereto.
  - 15.3 Owner Default: Failure of the Owner, which as neither been remedied nor waived, to pay the Contractor as required by the Construction Contract or to perform and complete or comply with other terms thereof.

# Construction Performance Bond

Any singular reference to Contractor, Surety, Owner of other party shall be considered plural where applicable.

---

CONTRACTOR (Name and Address):

SURETY (Name and Address of Principal Place of Business):

OWNER (Name and Address):

CONSTRUCTION CONTRACT

Date: Amount:

Description (Name and Location):

BOND

Date (Not earlier than Construction Contract Date):

Amount:

Modifications to this Bond Form:

Surety and Contractor, intending to be legally bound hereby, subject to the terms printed on the reverse side hereof, do each cause this Construction Payment Bond to be duly executed on its behalf by its authorized officer, agent or representative.

CONTRACTOR AS PRINCIPAL

Company: (Corp. Seal)

Signature: \_\_\_\_\_

Name and Title:

SURETY

Company: (Corp. Seal)

Signature: \_\_\_\_\_

Name and Title:

(Attach Power of Attorney)

(Space is provided below for signatures of additional parties, if required.)

CONTRACTOR AS PRINCIPAL

Company: (Corp. Seal)

Signature: \_\_\_\_\_

Name and Title:

SURETY

Company: (Corp. Seal)

Signature: \_\_\_\_\_

Name and Title:

EJCDC No. 1910-28-B (1996 Edition)

Originally prepared through the joint efforts of the Surety Association of America, Engineers Joint Contract Documents Committee, the Associated General Contractors of America, and the American Institute of Architects.

1. The Contractor and the Surety, jointly and severally, bind themselves, their heirs, executors, administrators, successors, and assigns to the Owner for the performance of the Construction Contract, which is incorporated herein by reference.
  2. If the Contractor performs the Construction Contract, the Surety and the Contractor shall have no obligation under this Bond, except to participate in conferences as provided in Subparagraph 3.1.
  3. If there is no Owner Default, the Surety's obligation under this Bond shall arise after:
    - 3.1 The Owner has notified the Contractor and the Surety at its address described in Paragraph 10 below, that the Owner is considering declaring a Contractor Default and has requested and attempted to arrange a conference with the Contractor and the Surety to be held not later than fifteen days after receipt of such notice to discuss methods of performing the Construction Contract. If the Owner and the Contractor and the Surety agree, the Contractor shall be allowed a reasonable time to perform the Construction Contract, but such an agreement shall not waive the Owner's right, if any subsequently to declare a Contractor Default; and
    - 3.2 The Owner has declared a Contractor Default and formally terminated the Contractor's right to complete the contract. Such Contractor Default shall not be declared earlier than twenty days after the Contractor and the Surety have received notice as provided in Subparagraph 3.1; and
    - 3.3 The Owner has agreed to pay the Balance of the Contract Price to the Surety in accordance with the terms of the Construction Contract or to a contractor selected to perform the Construction Contract in accordance with the terms of the contract with the Owner.
  4. When the Owner has satisfied the conditions of Paragraph 3, the Surety shall promptly and at the Surety's expense take one of the following actions:
    - 4.1 Arrange for the Contractor, with Consent of the Owner, to perform and complete the Construction Contract; or
    - 4.2 Undertake to perform and complete the Construction Contract itself, through its agents or through independent contractors; or
    - 4.3 Obtain bids or negotiated proposals from qualified contractors acceptable to the Owner for Contract or performance and completion of the Construction Contract, arrange for a contract to be prepared for execution by the Owner and the Contractor selected with the Owner's concurrence, to be secured with performance and payment bonds executed by qualified surety equivalent to the bonds issued on the Construction Contract, and pay to the Owner the amount of damages as described in Paragraph 6 in excess of the Balance of the Contract Price incurred by the Owner resulting from the Contractor's default; or
    - 4.4 Waive its right to perform and complete, arrange for completion, or obtain a new contractor and with reasonable promptness under the circumstances.
      1. After investigation, determine the amount for which it may be liable to the Owner and, as soon as practicable after the amount is determined, tender payment therefore to the Owner; or
      2. Deny liability in whole or in part and notify the Owner citing reasons therefor.
  5. If the Surety does not proceed as provided in Paragraph 4 with reasonable promptness, the Surety shall be deemed to be in default on this bond fifteen days after receipt of an additional written notice from the Owner to the Surety demanding that the Surety perform its obligations under this Bond, and the Owner shall be entitled to enforce any remedy available to the Owner. If the Surety proceeds as provided in Subparagraph 4.4, and the Owner refuses the payment tendered or the Surety has denied liability, in whole or in part, without further notice the Owner shall be entitled to enforce any remedy available to the Owner.
  6. After the Owner has terminated the Contractor's right to complete the Construction Contract, and if the Surety elects to act under Subparagraph 4.1, 4.2, or 4.3 above, then the responsibilities of the Surety to the Owner shall not be greater than those of the Contractor under the Construction Contract, and the responsibilities of the Owner to the Surety shall not be greater than those of the Owner under the Construction Contract.
- 6.1 The responsibilities of the Contractor for correction of defective work and completion of the Construction Contract:
  - 6.2 Additional legal, design professional and delay costs resulting from the Contractor's Default, and resulting from the actions or failure to act of the Surety under Paragraph 4; and
  - 6.3 Liquidated damages, or if no liquidated damages are specified in the Construction Contract, actual damages caused by delayed performance or non-performance of the Contractor.
  7. The Surety shall not be liable to the Owner or others for obligations of the Contractor that are unrelated to the Construction Contract, and the Balance of the Contract Price shall not be reduced or set off on account of any such unrelated obligations. No right of action shall accrue on this Bond to any person or entity other than the Owner or its heirs, executors, administrators, or successors.
  8. The Surety hereby waives notice of any change, include changes of time to the Construction Contract or to related subcontracts, purchase orders and other obligations.
  9. Any proceeding, legal, or equitable, under this Bond may be instituted in any court of competent jurisdiction in the location in which the work or part of the work is located and shall be instituted within two years after Contractor Default or within two years after the Contractor ceased working or within two years after the Surety refuses or fails to perform its obligations under this Bond, whichever occurs first. If the provisions of this Paragraph are void or prohibited by the law, the minimum period of limitation available to sureties as a defense in the jurisdiction of the suit shall be applicable.
  10. Notice to the Surety, the Owner or the Contractor shall be mailed or delivered to the address shown on the signature page.
  11. When this bond has been furnished to comply with a statutory or other legal requirements in the location where the construction was to be performed, any provision in this Bond conflicting with said statutory or legal requirements shall be deemed deleted here from and provisions conforming to such statutory or other legal requirements shall be deemed incorporated herein. The intent is that this Bond shall be construed as a statutory bond and not as a common law bond.
  12. Definitions.
    - 12.1 Balance of the Contract Price: The total amount payable by the Owner to the Contractor under the Construction Contract after all proper adjustments have been made, including allowance to the Contractor of any amount received or to be received by the Owner in settlement of insurance or other claims for damages to which the Contractor is entitled, reduce by all valid and proper payments made to or on behalf of the Contractor under the Construction Contract.
    - 12.2 Construction Contract: The agreement between the Owner and the Contractor identified on the signature page, including all Contract Documents and changes thereto.
    - 12.3 Contractor Default: Failure of the Contractor, which has neither been remedied nor waived, to perform or otherwise to comply with the terms of the Construction Contract.
    - 12.4 Owner Default: Failure of the Owner, which has neither been remedied nor waived, to pay the Contractor as required by the Construction Contract to perform and complete or comply with other terms thereof.

**APPENDIX 12-1  
CONSTRUCTION CONTRACT REQUIREMENTS**

**Contents**

**CERTIFICATION REGARDING DEBARMENT, SUSPENSION, INELIGIBILITY, AND VOLUNTARY EXCLUSION (FHWA SECTION 1273 X)**

**CERTIFICATION REGARDING USE OF CONTRACT FUNDS FOR LOBBYING (FHWA 1273 Section XI)**

**FALSE CLAIMS CERTIFICATION (31 USC §3729, NYS FINANCE LAW ARTICLE 13)**

**NON-COLLUSIVE BIDDING CERTIFICATION (49 CFR 29)**

**REPORTING VIOLATIONS OF NON-COLLUSIVE BIDDING PROCEDURES**

**GOALS FOR EQUAL EMPLOYMENT OPPORTUNITY (EEO) PARTICIPATION**

**REQUIRED CONTRACT PROVISIONS**

**FEDERAL-AID CONSTRUCTION CONTRACTS.**

**ALL FORMS MUST BE INCLUDED IN ALL FEDERAL AID CONTRACTS AND MUST BE INCLUDED IN EACH BID PROPOSAL.**



**CERTIFICATION REGARDING DEBARMENT, SUSPENSION, INELIGIBILITY, AND VOLUNTARY EXCLUSION. (FHWA Section 1273 X.)**

A. The Bidder certifies to the best of its knowledge and belief, that it and its Principals:

1. Are not presently debarred, suspended, proposed for debarment, declared ineligible, or voluntarily excluded from participating in covered transactions by any Federal department or agency;

2. Have not within a three-year period preceding this proposal been convicted of or had a civil judgment rendered against them for commission of fraud or a criminal offense in connection with obtaining, attempting to obtain, or performing a public (Federal, State, or local) transaction or contract under a public transaction; violation of Federal or State antitrust statutes or commission of embezzlement, theft, forgery, bribery, falsification or destruction of records, making false statements or receiving stolen property;

3. Are not presently indicted for or otherwise criminally or civilly charged by a governmental entity (Federal, State or local) with the commission of any of the offenses enumerated in paragraph (a)(2) of this certification; and

4. Have not within a three-year period preceding this application/proposal had one or more public transactions (Federal, State or local) terminated for cause or default.

B. Where the Bidder is unable to certify to any of the statements in this certification, such prospective participant shall attach an explanation to this proposal.

**CERTIFICATION REGARDING USE OF CONTRACT FUNDS FOR LOBBYING. (FHWA 1273 Section XI.)**

A. The prospective participant certifies, by signing and submitting this bid or proposal, to the best of his/her knowledge and belief, that:

1. No Federal appropriated funds have been paid or will be paid, by or on behalf of the undersigned, to any person for influencing or attempting to influence an officer or employee of any Federal agency, a Member of Congress, an officer or employee of Congress, or an employee of a Member of Congress, in connection with the awarding of any Federal contract, the making of any Federal grant, the making of any Federal loan, the entering into of any cooperative agreement, and the extension, continuation, renewal, amendment, or modification of any Federal contract, grant, loan, or cooperative agreement.

2. If any funds other than Federal appropriated funds have been paid or will be paid to any person for influencing or attempting to influence an officer or employee of any Federal agency, a Member of Congress, an officer or employee of Congress, or an employee of a Member of Congress, in connection with this Federal contract, grant, loan, or cooperative agreement, the undersigned shall complete and submit Standard Form-LLL, "Disclosure Form to Report Lobbying", in accordance with its instructions.

B. This certification is a material representation of fact upon which reliance was placed when this transaction was made or entered into. Submission of this certification is a prerequisite for making or entering into this transaction imposed by Section 1352, Title 31, U. S. Code. Any person who fails to file the required certification shall be subject to a civil penalty of not less than \$10,000.00 and not more than \$100,000.00 for each such failure.

C. The prospective participant also agrees by submitting his/her bid or proposal that he/she shall require that the language of this certification be included in all lower tier subcontracts which exceed \$100,000.00 and that such subrecipients shall certify and disclose accordingly.

**THESE MUST BE INCLUDED IN ALL FEDERAL AID CONTRACTS, AND MUST BE INCLUDED IN EACH BID PROPOSAL.**

**FALSE CLAIMS CERTIFICATION (31 USC §3729, NYS Finance Law Article 13)**

Under the Federal False Claims Act, 31 U.S. Code §3729, any person or entity who knowingly presents, or causes to be presented to the Federal Government, a false or fraudulent claim for payment or approval is liable to the United State Government for a civil penalty of not less than \$5,000 and not more than \$10,000, plus three times the amount of damages the Government sustains.

Under the New York State False Claims Act, NYS Finance Law Article 13, any person or entity who knowingly presents or causes to be presented to the State of New York or Local Governments within the State of New York, a false or fraudulent claim for payment or approval is liable to the Government for a civil penalty of not less than \$6,000 and not more than \$12,000, plus three times the amount of damages the Government sustains.

“Knowingly” is defined as (1) actual knowledge; (2) acting in deliberate ignorance of the truth or falsity of information; or (3) acting in reckless disregard of the truth or falsity of information; no proof of specific intent to defraud is required.

The Contractor to whom the above-identified contract is to be awarded does hereby certify to New York State Department of Transportation that it understands the prohibitions under the Federal and New York State False Claims Acts and that it has not and will not submit or cause to be submitted any fraudulent claims in the submission of this bid or in connection with the above-identified contract. The Contractor further certifies that it understands retaliatory actions, against employees and officers who initiate a *Qui Tam* (public) action on behalf of the government or cooperate in the investigation of a false claim, are prohibited and are subject to an assessment of damages and penalties, under the provisions of the Federal and New York State False Claims Acts.

**THIS MUST BE INCLUDED IN ALL FEDERAL AID CONTRACTS AND MUST BE INCLUDED IN EACH BID PROPOSAL.**

**NON-COLLUSIVE BIDDING CERTIFICATION  
(NYS FINANCE LAW §139-d and GENERAL MUNICIPAL LAW §103-d)**

1. By submission of this bid:

(a) Each bidder and each person signing on behalf of any bidder certifies, and in the case of a joint bid, each party thereto certifies as to its own organization, under penalty of perjury, that to the best of his knowledge and belief:

(1) The prices in this bid have been arrived at independently without collusion, consultation, communication, or agreement, for the purpose of restricting competition, as to any matter relating to such prices with any other bidder or with any competitor,

(2) Unless otherwise required by law, the prices which have been quoted in this bid have not been knowingly disclosed by the bidder and will not knowingly be disclosed by the bidder prior to opening, directly or indirectly, to any other bidder or to any competitor; and

(3) No attempt has been made or will be made by the bidder to induce any other person, partnership, or corporation to submit or not to submit a bid for the purpose of restricting competition.

(b) A bid shall not be considered for award nor shall any award be made where (a)(1)(2) and (3) above have not been complied with; provided, however, that if in any case, the bidder cannot make the foregoing certification, the bidder shall so state and shall furnish with the bid a signed statement which sets forth in detail the reasons, therefore. Where (a)(1)(2) and (3) above have not been complied with, the bid shall not be considered for award nor shall any award be made unless the head of the purchasing unit of the state, public department, or agency to which the bid is made, or his designee, determines that such disclosure was not made for the purpose of restricting competition.

The fact that the bidder (a) has published price lists, rates, or tariffs covering items being procured, (b) has informed prospective customers of proposed or pending publication of new or revised price-lists for such items or (c) has sold the same items to other customers at the same prices being bid, does not constitute, without more, a disclosure within the meaning of subparagraph one (a).

2. Any bid hereafter made to the state or any public department, agency, or official thereof by a corporate bidder for work or services performed or to be performed or goods sold or to be sold, where competitive bidding is required by statute, rule, or regulation, and where such bid contains the certification referred to in subdivision one of this section, shall be deemed to have been authorized by the board of directors of the bidder and such authorization shall be deemed to have included the signing and submission of the bid and the inclusion therein of the certificate as to non-collusion as the act and deed of the corporation."

**STATE NON-COLLUSIVE BIDDING CERTIFICATIONS MUST BE INCLUDED IN EVERY BID PROPOSAL REGARDLESS OF WHETHER NYSDOT SPECIFICATIONS OR LOCAL SPECIFICATIONS ARE USED.**

### **NON-COLLUSIVE BIDDING CERTIFICATION (2 CFR 1200)**

"By submission of this bid, the bidder does hereby tender to the Owner this sworn statement pursuant to Section 1128 of Title 23, U. S. Code-Highways and does hereby certify, in conformance with said Section 112 of Title 23, U. S. Code-Highways that the said Contractor has not, either directly or indirectly, entered into any agreement, participated in any collusion, or otherwise taken any action in restraint of free competitive bidding in connection with the above contract."

The signatory to the proposal, being duly sworn, certifies that, EXCEPT AS NOTED BELOW, his/her company and any person associated therewith in the capacity of owner, partner, director, officer, or major stockholder (of five percent or more ownership):

1. Is not currently under suspension, debarment, voluntary exclusion, or determination of ineligibility by any Federal agency,
2. Has not been suspended, debarred, voluntarily excluded, or determined ineligible by any Federal agency within the past three years,
3. Does not have a proposed debarment pending; and
4. Has not been indicted, convicted, or had a civil judgment rendered against it by a court of competent jurisdiction in any matter involving fraud or official misconduct within the past three years.

EXCEPTIONS: The Contractor should list any relevant information, attaching additional sheets to the proposal if necessary. (Exceptions will not necessarily result in disapproval but will be considered in determining responsibility. For any exception noted, the Contractor should indicate to whom it applies, the initiating agency, and the dates of actions. Providing false information may result in criminal prosecution or administrative sanctions).

**FEDERAL NON-COLLUSIVE BIDDING CERTIFICATION MUST BE INCLUDED IN EVERY BID PROPOSAL REGARDLESS OF WHETHER NYSDOT SPECIFICATIONS OR LOCAL SPECIFICATIONS ARE USED.**

**REPORTING VIOLATIONS OF NON-COLLUSIVE BIDDING PROCEDURES, MISCONDUCT, OR  
OTHER PROHIBITED CONTRACT ACTIVITIES**

**US DEPARTMENT OF TRANSPORTATION  
OFFICE OF INSPECTOR GENERAL - FRAUD, WASTE & ABUSE HOTLINE**

The U.S. Department of Transportation (USDOT) Office of Inspector General (OIG) maintains a Hotline for receiving allegations of fraud, waste, abuse, or mismanagement in USDOT programs or operations. Persons with knowledge of bid collusion (i.e., contractors, suppliers, work persons, etc.), or other questionable contract related practices (inadequate materials, poor workmanship, theft of materials, etc.), are encouraged to report such activities by calling the Hotline at 1-800-424-9071, emailing [hotline@oig.dot.gov](mailto:hotline@oig.dot.gov), or writing to the USDOT Inspector General, 1200 New Jersey Ave SE, West Bldg. 7th Floor, Washington, DC 20590. Allegations may be reported 24 hours a day, seven days a week by DOT employees, contractors, or the general public.

**NEW YORK STATE OFFICE OF THE INSPECTOR GENERAL HOTLINE**

The New York State Office of the Inspector General maintains a Hotline for receiving allegations of governmental misconduct. Reports of New York State governmental misconduct may be made in strict confidence to the Toll-Free 24-hour Statewide HOTLINE at 1-800-DO RIGHT (1-800-367-4448), the online complaint form at [www.ig.ny.gov](http://www.ig.ny.gov) or in writing to the New York State Office of the Inspector General, Empire State Plaza, Agency Building 2 - 16th Floor, Albany, New York 12223.

**THIS PAGE MUST BE INCLUDED IN ALL FEDERAL AID CONTRACTS, AND MUST BE  
INCLUDED IN EACH BID PROPOSAL**

**GOALS FOR EQUAL EMPLOYMENT OPPORTUNITY (EEO) PARTICIPATION**

The Contractor shall follow the requirements of NYSDOT Standard Specification §102-11 *Equal Employment Opportunity Requirements*. The goals for minority and female participation, expressed in percentage terms for the Contractor’s aggregate workforce in each trade on all construction work in the covered area, which is the county or counties in which the work is located, are as follows:

<b>GOALS FOR PARTICIPATION OF MINORITIES</b>					
<b>COUNTY</b>	<b>%</b>	<b>COUNTY</b>	<b>%</b>	<b>COUNTY</b>	<b>%</b>
Albany	3.2	Herkimer	2.1	Richmond	Table
Allegany	6.3	Jefferson	2.5	Rockland	22.6
Broome	1.1	Kings	Table	St. Lawrence	2.5
Bronx	Table	Lewis	2.5	Saratoga	3.2
Cattaraugus	6.3	Livingston	5.3	Schenectady	3.2
Cayuga	2.5	Madison	3.8	Schoharie	2.6
Chautauqua	6.3	Monroe	5.3	Schuyler	1.2
Chemung	2.2	Montgomery	3.2	Seneca	5.9
Chenango	1.2	Nassau	5.8	Steuben	1.2
Clinton	2.6	New York	Table	Suffolk	5.8
Columbia	2.6	Niagara	7.7	Sullivan	17.0
Cortland	2.5	Oneida	2.1	Tioga	1.1
Delaware	1.2	Onondaga	3.8	Tompkins	1.2
Dutchess	6.4	Ontario	5.3	Ulster	17.0
Erie	7.7	Orange	17.0	Warren	2.6
Essex	2.6	Orleans	5.3	Washington	2.6
Franklin	2.5	Oswego	3.8	Wayne	5.3
Fulton	2.6	Otsego	1.2	Westchester	22.6
Genesee	5.9	Putnam	22.6	Wyoming	6.3
Greene	2.6	Queens	Table	Yates	5.9
Hamilton	2.6	Rensselaer	3.2		

(45 FR 65976 – 10/3/1980)

<b>GOALS FOR PARTICIPATION OF MINORITIES BRONX, KINGS, NEW YORK, QUEENS AND RICHMOND COUNTIES</b>			
Electricians	9.0 to 10.2	Bricklayers	13.4 to 15.5
Carpenters	27.6 to 32.0	Asbestos workers	22.8 to 28.0
Steam fitters	12.2 to 13.5	Roofers	6.3 to 7.5
Metal lathers	24.6 to 25.6	Iron workers (ornamental)	22.4 to 23.0
Painters	26.0 to 28.6	Cement masons	23.0 to 27.0
Operating engineers	25.6 to 26.0	Glaziers	16.0 to 20.0
Plumbers	12.0 to 14.5	Plasterers	15.8 to 18.0
Iron workers (structural)	25.9 to 32.0	Teamsters	22.0 to 22.5
Elevator constructors	5.5 to 6.5	Boilermakers	13.0 to 15.5
		All others	16.4 to 17.5

(43 FR 14888 – 4/7/1978)

**GOAL FOR PARTICIPATION OF WOMEN**

The goal for the participation of women is 6.9%.

These goals are applicable to all the Contractor's construction work (whether or not it is Federal or federally assisted). If the Contractor performs construction work outside of New York State, it shall apply the goals established for the covered area where the work is actually performed.

## **REQUIRED CONTRACT PROVISIONS FEDERAL-AID CONSTRUCTION CONTRACTS**

- I. General
- II. Nondiscrimination
- III. Nonsegregated Facilities
- IV. Davis-Bacon and Related Act Provisions
- V. Contract Work Hours and Safety Standards Act Provisions
- VI. Subletting or Assigning the Contract
- VII. Safety: Accident Prevention
- VIII. False Statements Concerning Highway Projects
- IX. Implementation of Clean Air Act and Federal Water Pollution Control Act
- X. Compliance with Governmentwide Suspension and Debarment Requirements
- XI. Certification Regarding Use of Contract Funds for Lobbying

### **ATTACHMENTS**

A. Employment and Materials Preference for Appalachian Development Highway System or Appalachian Local Access Road Contracts (included in Appalachian contracts only)

### **I. GENERAL**

1. Form FHWA-1273 must be physically incorporated in each construction contract funded under Title 23 (excluding emergency contracts solely intended for debris removal). The contractor (or subcontractor) must insert this form in each subcontract and further require its inclusion in all lower tier subcontracts (excluding purchase orders, rental agreements and other agreements for supplies or services).

The applicable requirements of Form FHWA-1273 are incorporated by reference for work done under any purchase order, rental agreement or agreement for other services. The prime contractor shall be responsible for compliance by any subcontractor, lower-tier subcontractor or service provider.

Form FHWA-1273 must be included in all Federal-aid design-build contracts, in all subcontracts and in lower tier subcontracts

(excluding subcontracts for design services, purchase orders, rental agreements and other agreements for supplies or services). The design-builder shall be responsible for compliance by any subcontractor, lower-tier subcontractor or service provider.

Contracting agencies may reference Form FHWA-1273 in bid proposal or request for proposal documents, however, the Form FHWA-1273 must be physically incorporated (not referenced) in all contracts, subcontracts and lower-tier subcontracts (excluding purchase orders, rental agreements and other agreements for supplies or services related to a construction contract).

2. Subject to the applicability criteria noted in the following sections, these contract provisions shall apply to all work performed on the contract by the contractor's own organization and with the assistance of workers under the contractor's immediate superintendence and to all work performed on the contract by piecework, station work, or by subcontract.

3. A breach of any of the stipulations contained in these Required Contract Provisions may be sufficient grounds for withholding of progress payments, withholding of final payment, termination of the contract, suspension / debarment or any other action determined to be appropriate by the contracting agency and FHWA.

4. Selection of Labor: During the performance of this contract, the contractor shall not use convict labor for any purpose within the limits of a construction project on a Federal-aid highway unless it is labor performed by convicts who are on parole, supervised release, or probation. The term Federal-aid highway does not include roadways functionally classified as local roads or rural minor collectors.

## II. NONDISCRIMINATION

The provisions of this section related to 23 CFR Part 230 are applicable to all Federal-aid construction contracts and to all related construction subcontracts of \$10,000 or more. The provisions of 23 CFR Part 230 are not applicable to material supply, engineering, or architectural service contracts.

In addition, the contractor and all subcontractors must comply with the following policies: Executive Order 11246, 41 CFR 60, 29 CFR 1625-1627, Title 23 USC Section 140, the Rehabilitation Act of 1973, as amended (29 USC 794), Title VI of the Civil Rights Act of 1964, as amended, and related regulations including 49 CFR Parts 21, 26 and 27; and 23 CFR Parts 200, 230, and 633.

The contractor and all subcontractors must comply with: the requirements of the Equal Opportunity Clause in 41 CFR 60-1.4(b) and, for all construction contracts exceeding \$10,000, the Standard Federal Equal Employment Opportunity Construction Contract Specifications in 41 CFR 60-4.3.

Note: The U.S. Department of Labor has exclusive authority to determine compliance with Executive Order 11246 and the policies of the Secretary of Labor including 41 CFR 60, and 29 CFR 1625-1627. The contracting agency and the FHWA have the authority and the responsibility to ensure compliance with Title 23 USC Section 140, the Rehabilitation Act of 1973, as amended (29 USC 794), and Title VI of the Civil Rights Act of 1964, as amended, and related regulations including 49 CFR Parts 21, 26 and 27; and 23 CFR Parts 200, 230, and 633.

The following provision is adopted from 23 CFR 230, Appendix A, with appropriate revisions to conform to the U.S. Department of Labor (US DOL) and FHWA requirements.

**1. Equal Employment Opportunity:** Equal employment opportunity (EEO) requirements not to discriminate and to take affirmative action to assure equal opportunity as set forth under laws, executive orders, rules, regulations (28 CFR 35, 29 CFR 1630, 29 CFR

1625-1627, 41 CFR 60 and 49 CFR 27) and orders of the Secretary of Labor as modified by the provisions prescribed herein, and imposed pursuant to 23 U.S.C. 140 shall constitute the EEO and specific affirmative action standards for the contractor's project activities under this contract. The provisions of the Americans with Disabilities Act of 1990 (42 U.S.C. 12101 et seq.) set forth under 28 CFR 35 and 29 CFR 1630 are incorporated by reference in this contract. In the execution of this contract, the contractor agrees to comply with the following minimum specific requirement activities of EEO:

- a. The contractor will work with the contracting agency and the Federal Government to ensure that it has made every good faith effort to provide equal opportunity with respect to all of its terms and conditions of employment and in their review of activities under the contract.
- b. The contractor will accept as its operating policy the following statement:

"It is the policy of this Company to assure that applicants are employed, and that employees are treated during employment, without regard to their race, religion, sex, color, national origin, age or disability. Such action shall include: employment, upgrading, demotion, or transfer; recruitment or recruitment advertising; layoff or termination; rates of pay or other forms of compensation; and selection for training, including apprenticeship, pre-apprenticeship, and/or on-the-job training."

**2. EEO Officer:** The contractor will designate and make known to the contracting officers an EEO Officer who will have the responsibility for and must be capable of effectively administering and promoting an active EEO program and who must be assigned adequate authority and responsibility to do so.

**3. Dissemination of Policy:** All members of the contractor's staff who are authorized to hire, supervise, promote, and discharge employees, or who recommend such action, or who are substantially involved in such action, will be made fully cognizant of, and will implement, the contractor's EEO policy and



contractual responsibilities to provide EEO in each grade and classification of employment. To ensure that the above agreement will be met, the following actions will be taken as a minimum:

a. Periodic meetings of supervisory and personnel office employees will be conducted before the start of work and then not less often than once every six months, at which time the contractor's EEO policy and its implementation will be reviewed and explained. The meetings will be conducted by the EEO Officer.

b. All new supervisory or personnel office employees will be given a thorough indoctrination by the EEO Officer, covering all major aspects of the contractor's EEO obligations within thirty days following their reporting for duty with the contractor.

c. All personnel who are engaged in direct recruitment for the project will be instructed by the EEO Officer in the contractor's procedures for locating and hiring minorities and women.

d. Notices and posters setting forth the contractor's EEO policy will be placed in areas readily accessible to employees, applicants for employment and potential employees.

e. The contractor's EEO policy and the procedures to implement such policy will be brought to the attention of employees by means of meetings, employee handbooks, or other appropriate means.

**4. Recruitment:** When advertising for employees, the contractor will include in all advertisements for employees the notation: "An Equal Opportunity Employer." All such advertisements will be placed in publications having a large circulation among minorities and women in the area from which the project work force would normally be derived.

a. The contractor will, unless precluded by a valid bargaining agreement, conduct systematic and direct recruitment through public and private employee referral sources likely to yield qualified minorities and women. To meet this requirement, the contractor will identify sources of potential minority group

employees, and establish with such identified sources procedures whereby minority and women applicants may be referred to the contractor for employment consideration.

b. In the event the contractor has a valid bargaining agreement providing for exclusive hiring hall referrals, the contractor is expected to observe the provisions of that agreement to the extent that the system meets the contractor's compliance with EEO contract provisions. Where implementation of such an agreement has the effect of discriminating against minorities or women, or obligates the contractor to do the same, such implementation violates Federal nondiscrimination provisions.

c. The contractor will encourage its present employees to refer minorities and women as applicants for employment. Information and procedures with regard to referring such applicants will be discussed with employees.

**5. Personnel Actions:** Wages, working conditions, and employee benefits shall be established and administered, and personnel actions of every type, including hiring, upgrading, promotion, transfer demotion, layoff, and termination, shall be taken without regard to race, color, religion, sex, national origin, age or disability. The following procedures shall be followed:

a. The contractor will conduct periodic inspections of project sites to insure that working conditions and employee facilities do not indicate discriminatory treatment of project site personnel.

b. The contractor will periodically evaluate the spread of wages paid within each classification to determine any evidence of discriminatory wage practices.

c. The contractor will periodically review selected personnel actions in depth to determine whether there is evidence of discrimination. Where evidence is found, the contractor will promptly take corrective action. If the review indicates that the discrimination may extend beyond the actions reviewed, such corrective action shall include all affected persons.

d. The contractor will promptly investigate all complaints of alleged discrimination made to the contractor in connection with its obligations under this contract, will attempt to resolve such complaints, and will take appropriate corrective action within a reasonable time. If the investigation indicates that the discrimination may affect persons other than the complainant, such corrective action shall include such other persons. Upon completion of each investigation, the contractor will inform every complainant of all of their avenues of appeal.

## **6. Training and Promotion:**

a. The contractor will assist in locating, qualifying, and increasing the skills of minorities and women who are applicants for employment or current employees. Such efforts should be aimed at developing full journey level status employees in the type of trade or job classification involved.

b. Consistent with the contractor's work force requirements and as permissible under Federal and State regulations, the contractor shall make full use of training programs, i.e., apprenticeship, and on-the-job training programs for the geographical area of contract performance. In the event a special provision for training is provided under this contract, this subparagraph will be superseded as indicated in the special provision. The contracting agency may reserve training positions for persons who receive welfare assistance in accordance with 23 U.S.C. 140(a).

c. The contractor will advise employees and applicants for employment of available training programs and entrance requirements for each.

d. The contractor will periodically review the training and promotion potential of employees who are minorities and women and will encourage eligible employees to apply for such training and promotion.

**7. Unions:** If the contractor relies in whole or in part upon unions as a source of employees, the contractor will use good faith efforts to obtain the cooperation of such unions to

increase opportunities for minorities and women. Actions by the contractor, either directly or through a contractor's association acting as agent, will include the procedures set forth below:

a. The contractor will use good faith efforts to develop, in cooperation with the unions, joint training programs aimed toward qualifying more minorities and women for membership in the unions and increasing the skills of minorities and women so that they may qualify for higher paying employment.

b. The contractor will use good faith efforts to incorporate an EEO clause into each union agreement to the end that such union will be contractually bound to refer applicants without regard to their race, color, religion, sex, national origin, age or disability.

c. The contractor is to obtain information as to the referral practices and policies of the labor union except that to the extent such information is within the exclusive possession of the labor union and such labor union refuses to furnish such information to the contractor, the contractor shall so certify to the contracting agency and shall set forth what efforts have been made to obtain such information.

d. In the event the union is unable to provide the contractor with a reasonable flow of referrals within the time limit set forth in the collective bargaining agreement, the contractor will, through independent recruitment efforts, fill the employment vacancies without regard to race, color, religion, sex, national origin, age or disability; making full efforts to obtain qualified and/or qualifiable minorities and women. The failure of a union to provide sufficient referrals (even though it is obligated to provide exclusive referrals under the terms of a collective bargaining agreement) does not relieve the contractor from the requirements of this paragraph. In the event the union referral practice prevents the contractor from meeting the obligations pursuant to Executive Order 11246, as amended, and these special provisions, such contractor shall immediately notify the contracting agency.

**8. Reasonable Accommodation for Applicants / Employees with Disabilities:**

The contractor must be familiar with the requirements for and comply with the Americans with Disabilities Act and all rules and regulations established there under. Employers must provide reasonable accommodation in all employment activities unless to do so would cause an undue hardship.

**9. Selection of Subcontractors, Procurement of Materials and Leasing of Equipment:**

The contractor shall not discriminate on the grounds of race, color, religion, sex, national origin, age or disability in the selection and retention of subcontractors, including procurement of materials and leases of equipment. The contractor shall take all necessary and reasonable steps to ensure nondiscrimination in the administration of this contract.

a. The contractor shall notify all potential subcontractors and suppliers and lessors of their EEO obligations under this contract.

b. The contractor will use good faith efforts to ensure subcontractor compliance with their EEO obligations.

**10. Assurance Required by 49 CFR 26.13(b):**

a. The requirements of 49 CFR Part 26 and the State DOT's U.S. DOT-approved DBE program are incorporated by reference.

b. The contractor or subcontractor shall not discriminate on the basis of race, color, national origin, or sex in the performance of this contract. The contractor shall carry out applicable requirements of 49 CFR Part 26 in the award and administration of DOT-assisted contracts. Failure by the contractor to carry out these requirements is a material breach of this contract, which may result in the termination of this contract or such other remedy as the contracting agency deems appropriate.

**11. Records and Reports:** The contractor shall keep such records as necessary to

document compliance with the EEO requirements. Such records shall be retained for a period of three years following the date of the final payment to the contractor for all contract work and shall be available at reasonable times and places for inspection by authorized representatives of the contracting agency and the FHWA.

a. The records kept by the contractor shall document the following:

(1) The number and work hours of minority and non-minority group members and women employed in each work classification on the project;

(2) The progress and efforts being made in cooperation with unions, when applicable, to increase employment opportunities for minorities and women; and

(3) The progress and efforts being made in locating, hiring, training, qualifying, and upgrading minorities and women;

b. The contractors and subcontractors will submit an annual report to the contracting agency each July for the duration of the project, indicating the number of minority, women, and non-minority group employees currently engaged in each work classification required by the contract work. This information is to be reported on [Form FHWA-1391](#). The staffing data should represent the project work force on board in all or any part of the last payroll period preceding the end of July. If on-the-job training is being required by special provision, the contractor will be required to collect and report training data. The employment data should reflect the work force on board during all or any part of the last payroll period preceding the end of July.

**III. NONSEGREGATED FACILITIES**

This provision is applicable to all Federal-aid construction contracts and to all related construction subcontracts of \$10,000 or more.

The contractor must ensure that facilities provided for employees are provided in such a manner that segregation on the basis of race, color, religion, sex, or national origin cannot result. The contractor may neither require such segregated use by written or oral policies nor tolerate such use by employee custom. The contractor's obligation extends further to ensure that its employees are not assigned to perform their services at any location, under the contractor's control, where the facilities are segregated. The term "facilities" includes waiting rooms, work areas, restaurants and other eating areas, time clocks, restrooms, washrooms, locker rooms, and other storage or dressing areas, parking lots, drinking fountains, recreation or entertainment areas, transportation, and housing provided for employees. The contractor shall provide separate or single-user restrooms and necessary dressing or sleeping areas to assure privacy between sexes.

#### **IV. DAVIS-BACON AND RELATED ACT PROVISIONS**

This section is applicable to all Federal-aid construction projects exceeding \$2,000 and to all related subcontracts and lower-tier subcontracts (regardless of subcontract size). The requirements apply to all projects located within the right-of-way of a roadway that is functionally classified as Federal-aid highway. This excludes roadways functionally classified as local roads or rural minor collectors, which are exempt. Contracting agencies may elect to apply these requirements to other projects.

The following provisions are from the U.S. Department of Labor regulations in 29 CFR 5.5 "Contract provisions and related matters" with minor revisions to conform to the FHWA-1273 format and FHWA program requirements.

##### **1. Minimum wages**

a. All laborers and mechanics employed or working upon the site of the work, will be paid unconditionally and not less often than once a week, and without subsequent deduction or rebate on any account (except such payroll deductions as are permitted by regulations issued by the Secretary of Labor under the

Copeland Act (29 CFR part 3)), the full amount of wages and bona fide fringe benefits (or cash equivalents thereof) due at time of payment computed at rates not less than those contained in the wage determination of the Secretary of Labor which is attached hereto and made a part hereof, regardless of any contractual relationship which may be alleged to exist between the contractor and such laborers and mechanics.

Contributions made or costs reasonably anticipated for bona fide fringe benefits under section 1(b)(2) of the Davis-Bacon Act on behalf of laborers or mechanics are considered wages paid to such laborers or mechanics, subject to the provisions of paragraph 1.d. of this section; also, regular contributions made or costs incurred for more than a weekly period (but not less often than quarterly) under plans, funds, or programs which cover the particular weekly period, are deemed to be constructively made or incurred during such weekly period. Such laborers and mechanics shall be paid the appropriate wage rate and fringe benefits on the wage determination for the classification of work actually performed, without regard to skill, except as provided in 29 CFR 5.5(a)(4). Laborers or mechanics performing work in more than one classification may be compensated at the rate specified for each classification for the time actually worked therein: Provided, That the employer's payroll records accurately set forth the time spent in each classification in which work is performed. The wage determination (including any additional classification and wage rates conformed under paragraph 1.b. of this section) and the Davis-Bacon poster (WH-1321) shall be posted at all times by the contractor and its subcontractors at the site of the work in a prominent and accessible place where it can be easily seen by the workers.

b. (1) The contracting officer shall require that any class of laborers or mechanics, including helpers, which is not listed in the wage determination and which is to be employed under the contract shall be classified in conformance with the wage determination. The contracting officer shall approve an additional classification and wage rate and

fringe benefits therefore only when the following criteria have been met:

(i) The work to be performed by the classification requested is not performed by a classification in the wage determination; and

(ii) The classification is utilized in the area by the construction industry; and

(iii) The proposed wage rate, including any bona fide fringe benefits, bears a reasonable relationship to the wage rates contained in the wage determination.

(2) If the contractor and the laborers and mechanics to be employed in the classification (if known), or their representatives, and the contracting officer agree on the classification and wage rate (including the amount designated for fringe benefits where appropriate), a report of the action taken shall be sent by the contracting officer to the Administrator of the Wage and Hour Division, Employment Standards Administration, U.S. Department of Labor, Washington, DC 20210. The Administrator, or an authorized representative, will approve, modify, or disapprove every additional classification action within 30 days of receipt and so advise the contracting officer or will notify the contracting officer within the 30-day period that additional time is necessary.

(3) In the event the contractor, the laborers or mechanics to be employed in the classification or their representatives, and the contracting officer do not agree on the proposed classification and wage rate (including the amount designated for fringe benefits, where appropriate), the contracting officer shall refer the questions, including the views of all interested parties and the recommendation of the contracting officer, to the Wage and Hour Administrator for determination. The Wage and Hour Administrator, or an authorized representative, will issue a determination within 30 days of receipt and so advise the contracting officer or will notify the contracting officer within the 30-day period that additional time is necessary.

(4) The wage rate (including fringe benefits where appropriate) determined pursuant to paragraphs 1.b.(2) or 1.b.(3) of this section, shall be paid to all workers performing work in the classification under this contract from the first day on which work is performed in the classification.

c. Whenever the minimum wage rate prescribed in the contract for a class of laborers or mechanics includes a fringe benefit which is not expressed as an hourly rate, the contractor shall either pay the benefit as stated in the wage determination or shall pay another bona fide fringe benefit or an hourly cash equivalent thereof.

d. If the contractor does not make payments to a trustee or other third person, the contractor may consider as part of the wages of any laborer or mechanic the amount of any costs reasonably anticipated in providing bona fide fringe benefits under a plan or program, Provided, That the Secretary of Labor has found, upon the written request of the contractor, that the applicable standards of the Davis-Bacon Act have been met. The Secretary of Labor may require the contractor to set aside in a separate account assets for the meeting of obligations under the plan or program.

## **2. Withholding**

The contracting agency shall upon its own action or upon written request of an authorized representative of the Department of Labor, withhold or cause to be withheld from the contractor under this contract, or any other Federal contract with the same prime contractor, or any other federally-assisted contract subject to Davis-Bacon prevailing wage requirements, which is held by the same prime contractor, so much of the accrued payments or advances as may be considered necessary to pay laborers and mechanics, including apprentices, trainees, and helpers, employed by the contractor or any subcontractor the full amount of wages required by the contract. In the event of failure to pay any laborer or mechanic, including any apprentice, trainee, or helper, employed or working on the site of the work, all or part of

the wages required by the contract, the contracting agency may, after written notice to the contractor, take such action as may be necessary to cause the suspension of any further payment, advance, or guarantee of funds until such violations have ceased.

### **3. Payrolls and basic records**

a. Payrolls and basic records relating thereto shall be maintained by the contractor during the course of the work and preserved for a period of three years thereafter for all laborers and mechanics working at the site of the work. Such records shall contain the name, address, and social security number of each such worker, his or her correct classification, hourly rates of wages paid (including rates of contributions or costs anticipated for bona fide fringe benefits or cash equivalents thereof of the types described in section 1(b)(2)(B) of the Davis-Bacon Act), daily and weekly number of hours worked, deductions made and actual wages paid. Whenever the Secretary of Labor has found under 29 CFR 5.5(a)(1)(iv) that the wages of any laborer or mechanic include the amount of any costs reasonably anticipated in providing benefits under a plan or program described in section 1(b)(2)(B) of the Davis-Bacon Act, the contractor shall maintain records which show that the commitment to provide such benefits is enforceable, that the plan or program is financially responsible, and that the plan or program has been communicated in writing to the laborers or mechanics affected, and records which show the costs anticipated or the actual cost incurred in providing such benefits. Contractors employing apprentices or trainees under approved programs shall maintain written evidence of the registration of apprenticeship programs and certification of trainee programs, the registration of the apprentices and trainees, and the ratios and wage rates prescribed in the applicable programs.

b. (1) The contractor shall submit weekly for each week in which any contract work is performed a copy of all payrolls to the contracting agency. The payrolls submitted shall set out accurately and completely all of

the information required to be maintained under 29 CFR 5.5(a)(3)(i), except that full social security numbers and home addresses shall not be included on weekly transmittals. Instead the payrolls shall only need to include an individually identifying number for each employee ( e.g. , the last four digits of the employee's social security number). The required weekly payroll information may be submitted in any form desired. Optional Form WH-347 is available for this purpose from the Wage and Hour Division Web site at <http://www.dol.gov/esa/whd/forms/wh347instr.htm> or its successor site. The prime contractor is responsible for the submission of copies of payrolls by all subcontractors. Contractors and subcontractors shall maintain the full social security number and current address of each covered worker, and shall provide them upon request to the contracting agency for transmission to the State DOT, the FHWA or the Wage and Hour Division of the Department of Labor for purposes of an investigation or audit of compliance with prevailing wage requirements. It is not a violation of this section for a prime contractor to require a subcontractor to provide addresses and social security numbers to the prime contractor for its own records, without weekly submission to the contracting agency.

(2) Each payroll submitted shall be accompanied by a "Statement of Compliance," signed by the contractor or subcontractor or his or her agent who pays or supervises the payment of the persons employed under the contract and shall certify the following:

(i) That the payroll for the payroll period contains the information required to be provided under §5.5 (a)(3)(ii) of Regulations, 29 CFR part 5, the appropriate information is being maintained under §5.5 (a)(3)(i) of Regulations, 29 CFR part 5, and that such information is correct and complete;

(ii) That each laborer or mechanic (including each helper, apprentice, and trainee) employed on the contract during the payroll period has been paid the full weekly wages earned, without rebate, either directly or indirectly, and that no deductions

have been made either directly or indirectly from the full wages earned, other than permissible deductions as set forth in Regulations, 29 CFR part 3;

(iii) That each laborer or mechanic has been paid not less than the applicable wage rates and fringe benefits or cash equivalents for the classification of work performed, as specified in the applicable wage determination incorporated into the contract.

(3) The weekly submission of a properly executed certification set forth on the reverse side of Optional Form WH-347 shall satisfy the requirement for submission of the "Statement of Compliance" required by paragraph 3.b.(2) of this section.

(4) The falsification of any of the above certifications may subject the contractor or subcontractor to civil or criminal prosecution under section 1001 of title 18 and section 231 of title 31 of the United States Code.

c. The contractor or subcontractor shall make the records required under paragraph 3.a. of this section available for inspection, copying, or transcription by authorized representatives of the contracting agency, the State DOT, the FHWA, or the Department of Labor, and shall permit such representatives to interview employees during working hours on the job. If the contractor or subcontractor fails to submit the required records or to make them available, the FHWA may, after written notice to the contractor, the contracting agency or the State DOT, take such action as may be necessary to cause the suspension of any further payment, advance, or guarantee of funds. Furthermore, failure to submit the required records upon request or to make such records available may be grounds for debarment action pursuant to 29 CFR 5.12.

#### **4. Apprentices and trainees**

##### **a. Apprentices (programs of the USDOL).**

Apprentices will be permitted to work at less than the predetermined rate for the work they performed when they are employed pursuant

to and individually registered in a bona fide apprenticeship program registered with the U.S. Department of Labor, Employment and Training Administration, Office of Apprenticeship Training, Employer and Labor Services, or with a State Apprenticeship Agency recognized by the Office, or if a person is employed in his or her first 90 days of probationary employment as an apprentice in such an apprenticeship program, who is not individually registered in the program, but who has been certified by the Office of Apprenticeship Training, Employer and Labor Services or a State Apprenticeship Agency (where appropriate) to be eligible for probationary employment as an apprentice.

The allowable ratio of apprentices to journeymen on the job site in any craft classification shall not be greater than the ratio permitted to the contractor as to the entire work force under the registered program. Any worker listed on a payroll at an apprentice wage rate, who is not registered or otherwise employed as stated above, shall be paid not less than the applicable wage rate on the wage determination for the classification of work actually performed. In addition, any apprentice performing work on the job site in excess of the ratio permitted under the registered program shall be paid not less than the applicable wage rate on the wage determination for the work actually performed. Where a contractor is performing construction on a project in a locality other than that in which its program is registered, the ratios and wage rates (expressed in percentages of the journeyman's hourly rate) specified in the contractor's or subcontractor's registered program shall be observed.

Every apprentice must be paid at not less than the rate specified in the registered program for the apprentice's level of progress, expressed as a percentage of the journeymen hourly rate specified in the applicable wage determination. Apprentices shall be paid fringe benefits in accordance with the provisions of the apprenticeship program. If the apprenticeship program does not specify fringe benefits, apprentices must be paid the full amount of fringe benefits listed on the wage

determination for the applicable classification. If the Administrator determines that a different practice prevails for the applicable apprentice classification, fringes shall be paid in accordance with that determination.

In the event the Office of Apprenticeship Training, Employer and Labor Services, or a State Apprenticeship Agency recognized by the Office, withdraws approval of an apprenticeship program, the contractor will no longer be permitted to utilize apprentices at less than the applicable predetermined rate for the work performed until an acceptable program is approved.

b. Trainees (programs of the USDOL).

Except as provided in 29 CFR 5.16, trainees will not be permitted to work at less than the predetermined rate for the work performed unless they are employed pursuant to and individually registered in a program which has received prior approval, evidenced by formal certification by the U.S. Department of Labor, Employment and Training Administration.

The ratio of trainees to journeymen on the job site shall not be greater than permitted under the plan approved by the Employment and Training Administration.

Every trainee must be paid at not less than the rate specified in the approved program for the trainee's level of progress, expressed as a percentage of the journeyman hourly rate specified in the applicable wage determination. Trainees shall be paid fringe benefits in accordance with the provisions of the trainee program. If the trainee program does not mention fringe benefits, trainees shall be paid the full amount of fringe benefits listed on the wage determination unless the Administrator of the Wage and Hour Division determines that there is an apprenticeship program associated with the corresponding journeyman wage rate on the wage determination which provides for less than full fringe benefits for apprentices. Any employee listed on the payroll at a trainee rate who is not registered and participating in a training plan approved by the Employment and Training Administration shall be paid not less than the applicable wage rate on the wage

determination for the classification of work actually performed. In addition, any trainee performing work on the job site in excess of the ratio permitted under the registered program shall be paid not less than the applicable wage rate on the wage determination for the work actually performed.

In the event the Employment and Training Administration withdraws approval of a training program, the contractor will no longer be permitted to utilize trainees at less than the applicable predetermined rate for the work performed until an acceptable program is approved.

c. Equal employment opportunity. The utilization of apprentices, trainees and journeymen under this part shall be in conformity with the equal employment opportunity requirements of Executive Order 11246, as amended, and 29 CFR part 30.

d. Apprentices and Trainees (programs of the U.S. DOT).

Apprentices and trainees working under apprenticeship and skill training programs which have been certified by the Secretary of Transportation as promoting EEO in connection with Federal-aid highway construction programs are not subject to the requirements of paragraph 4 of this Section IV. The straight time hourly wage rates for apprentices and trainees under such programs will be established by the particular programs. The ratio of apprentices and trainees to journeymen shall not be greater than permitted by the terms of the particular program.

**5. Compliance with Copeland Act requirements.** The contractor shall comply with the requirements of 29 CFR part 3, which are incorporated by reference in this contract.

**6. Subcontracts.** The contractor or subcontractor shall insert Form FHWA-1273 in any subcontracts and also require the subcontractors to include Form FHWA-1273 in any lower tier subcontracts. The prime contractor shall be responsible for the compliance by any subcontractor or lower tier subcontractor with all the contract clauses in 29 CFR 5.5.



**7. Contract termination: debarment.** A breach of the contract clauses in 29 CFR 5.5 may be grounds for termination of the contract, and for debarment as a contractor and a subcontractor as provided in 29 CFR 5.12.

**8. Compliance with Davis-Bacon and Related Act requirements.** All rulings and interpretations of the Davis-Bacon and Related Acts contained in 29 CFR parts 1, 3, and 5 are herein incorporated by reference in this contract.

**9. Disputes concerning labor standards.** Disputes arising out of the labor standards provisions of this contract shall not be subject to the general disputes clause of this contract. Such disputes shall be resolved in accordance with the procedures of the Department of Labor set forth in 29 CFR parts 5, 6, and 7. Disputes within the meaning of this clause include disputes between the contractor (or any of its subcontractors) and the contracting agency, the U.S. Department of Labor, or the employees or their representatives.

**10. Certification of eligibility.**

a. By entering into this contract, the contractor certifies that neither it (nor he or she) nor any person or firm who has an interest in the contractor's firm is a person or firm ineligible to be awarded Government contracts by virtue of section 3(a) of the Davis-Bacon Act or 29 CFR 5.12(a)(1).

b. No part of this contract shall be subcontracted to any person or firm ineligible for award of a Government contract by virtue of section 3(a) of the Davis-Bacon Act or 29 CFR 5.12(a)(1).

c. The penalty for making false statements is prescribed in the U.S. Criminal Code, 18 U.S.C. 1001.

**V. CONTRACT WORK HOURS AND SAFETY STANDARDS ACT**

The following clauses apply to any Federal-aid construction contract in an amount in excess of \$100,000 and subject to the overtime provisions of the Contract Work Hours and Safety Standards Act. These clauses shall be

inserted in addition to the clauses required by 29 CFR 5.5(a) or 29 CFR 4.6. As used in this paragraph, the terms laborers and mechanics include watchmen and guards.

**1. Overtime requirements.** No contractor or subcontractor contracting for any part of the contract work which may require or involve the employment of laborers or mechanics shall require or permit any such laborer or mechanic in any workweek in which he or she is employed on such work to work in excess of forty hours in such workweek unless such laborer or mechanic receives compensation at a rate not less than one and one-half times the basic rate of pay for all hours worked in excess of forty hours in such workweek.

**2. Violation; liability for unpaid wages; liquidated damages.** In the event of any violation of the clause set forth in paragraph (1.) of this section, the contractor and any subcontractor responsible therefor shall be liable for the unpaid wages. In addition, such contractor and subcontractor shall be liable to the United States (in the case of work done under contract for the District of Columbia or a territory, to such District or to such territory), for liquidated damages. Such liquidated damages shall be computed with respect to each individual laborer or mechanic, including watchmen and guards, employed in violation of the clause set forth in paragraph (1.) of this section, in the sum of \$10 for each calendar day on which such individual was required or permitted to work in excess of the standard workweek of forty hours without payment of the overtime wages required by the clause set forth in paragraph (1.) of this section.

**3. Withholding for unpaid wages and liquidated damages.** The FHWA or the contracting agency shall upon its own action or upon written request of an authorized representative of the Department of Labor withhold or cause to be withheld, from any moneys payable on account of work performed by the contractor or subcontractor under any such contract or any other Federal contract with the same prime contractor, or any other federally-assisted contract subject to the Contract Work Hours and Safety Standards

Act, which is held by the same prime contractor, such sums as may be determined to be necessary to satisfy any liabilities of such contractor or subcontractor for unpaid wages and liquidated damages as provided in the clause set forth in paragraph (2.) of this section.

**4. Subcontracts.** The contractor or subcontractor shall insert in any subcontracts the clauses set forth in paragraph (1.) through (4.) of this section and also a clause requiring the subcontractors to include these clauses in any lower tier subcontracts. The prime contractor shall be responsible for compliance by any subcontractor or lower tier subcontractor with the clauses set forth in paragraphs (1.) through (4.) of this section.

## **VI. SUBLETTING OR ASSIGNING THE CONTRACT**

This provision is applicable to all Federal-aid construction contracts on the National Highway System.

1. The contractor shall perform with its own organization contract work amounting to not less than 30 percent (or a greater percentage if specified elsewhere in the contract) of the total original contract price, excluding any specialty items designated by the contracting agency. Specialty items may be performed by subcontract and the amount of any such specialty items performed may be deducted from the total original contract price before computing the amount of work required to be performed by the contractor's own organization (23 CFR 635.116).

a. The term "perform work with its own organization" refers to workers employed or leased by the prime contractor, and equipment owned or rented by the prime contractor, with or without operators. Such term does not include employees or equipment of a subcontractor or lower tier subcontractor, agents of the prime contractor, or any other assignees. The term may include payments for the costs of hiring leased employees from an employee leasing firm meeting all relevant Federal and State regulatory requirements. Leased employees may only be included in

this term if the prime contractor meets all of the following conditions:

(1) the prime contractor maintains control over the supervision of the day-to-day activities of the leased employees;

(2) the prime contractor remains responsible for the quality of the work of the leased employees;

(3) the prime contractor retains all power to accept or exclude individual employees from work on the project; and

(4) the prime contractor remains ultimately responsible for the payment of predetermined minimum wages, the submission of payrolls, statements of compliance and all other Federal regulatory requirements.

c. "Specialty Items" shall be construed to be limited to work that requires highly specialized knowledge, abilities, or equipment not ordinarily available in the type of contracting organizations qualified and expected to bid or propose on the contract as a whole and in general are to be limited to minor components of the overall contract.

2. The contract amount upon which the requirements set forth in paragraph (1) of Section VI is computed includes the cost of material and manufactured products which are to be purchased or produced by the contractor under the contract provisions.

3. The contractor shall furnish (a) a competent superintendent or supervisor who is employed by the firm, has full authority to direct performance of the work in accordance with the contract requirements, and is in charge of all construction operations (regardless of who performs the work) and (b) such other of its own organizational resources (supervision, management, and engineering services) as the contracting officer determines is necessary to assure the performance of the contract.

4. No portion of the contract shall be sublet, assigned or otherwise disposed of except with the written consent of the contracting officer, or authorized representative, and such consent when given shall not be construed to relieve

the contractor of any responsibility for the fulfillment of the contract. Written consent will be given only after the contracting agency has assured that each subcontract is evidenced in writing and that it contains all pertinent provisions and requirements of the prime contract.

5. The 30% self-performance requirement of paragraph (1) is not applicable to design-build contracts; however, contracting agencies may establish their own self-performance requirements.

### **VII. SAFETY: ACCIDENT PREVENTION**

This provision is applicable to all Federal-aid construction contracts and to all related subcontracts.

1. In the performance of this contract the contractor shall comply with all applicable Federal, State, and local laws governing safety, health, and sanitation (23 CFR 635). The contractor shall provide all safeguards, safety devices and protective equipment and take any other needed actions as it determines, or as the contracting officer may determine, to be reasonably necessary to protect the life and health of employees on the job and the safety of the public and to protect property in connection with the performance of the work covered by the contract.

2. It is a condition of this contract, and shall be made a condition of each subcontract, which the contractor enters into pursuant to this contract, that the contractor and any subcontractor shall not permit any employee, in performance of the contract, to work in surroundings or under conditions which are unsanitary, hazardous or dangerous to his/her health or safety, as determined under construction safety and health standards (29 CFR 1926) promulgated by the Secretary of Labor, in accordance with Section 107 of the Contract Work Hours and Safety Standards Act (40 U.S.C. 3704).

3. Pursuant to 29 CFR 1926.3, it is a condition of this contract that the Secretary of Labor or authorized representative thereof, shall have right of entry to any site of contract

performance to inspect or investigate the matter of compliance with the construction safety and health standards and to carry out the duties of the Secretary under Section 107 of the Contract Work Hours and Safety Standards Act (40 U.S.C.3704).

### **VIII. FALSE STATEMENTS CONCERNING HIGHWAY PROJECTS**

This provision is applicable to all Federal-aid construction contracts and to all related subcontracts.

In order to assure high quality and durable construction in conformity with approved plans and specifications and a high degree of reliability on statements and representations made by engineers, contractors, suppliers, and workers on Federal-aid highway projects, it is essential that all persons concerned with the project perform their functions as carefully, thoroughly, and honestly as possible. Willful falsification, distortion, or misrepresentation with respect to any facts related to the project is a violation of Federal law. To prevent any misunderstanding regarding the seriousness of these and similar acts, Form FHWA-1022 shall be posted on each Federal-aid highway project (23 CFR 635) in one or more places where it is readily available to all persons concerned with the project:

18 U.S.C. 1020 reads as follows:

"Whoever, being an officer, agent, or employee of the United States, or of any State or Territory, or whoever, whether a person, association, firm, or corporation, knowingly makes any false statement, false representation, or false report as to the character, quality, quantity, or cost of the material used or to be used, or the quantity or quality of the work performed or to be performed, or the cost thereof in connection with the submission of plans, maps, specifications, contracts, or costs of construction on any highway or related project submitted for approval to the Secretary of Transportation; or

Whoever knowingly makes any false statement, false representation, false report or false claim with respect to the character,

quality, quantity, or cost of any work performed or to be performed, or materials furnished or to be furnished, in connection with the construction of any highway or related project approved by the Secretary of Transportation; or

Whoever knowingly makes any false statement or false representation as to material fact in any statement, certificate, or report submitted pursuant to provisions of the Federal-aid Roads Act approved July 1, 1916, (39 Stat. 355), as amended and supplemented;

Shall be fined under this title or imprisoned not more than 5 years or both."

#### **IX. IMPLEMENTATION OF CLEAN AIR ACT AND FEDERAL WATER POLLUTION CONTROL ACT**

This provision is applicable to all Federal-aid construction contracts and to all related subcontracts.

By submission of this bid/proposal or the execution of this contract, or subcontract, as appropriate, the bidder, proposer, Federal-aid construction contractor, or subcontractor, as appropriate, will be deemed to have stipulated as follows:

1. That any person who is or will be utilized in the performance of this contract is not prohibited from receiving an award due to a violation of Section 508 of the Clean Water Act or Section 306 of the Clean Air Act.
2. That the contractor agrees to include or cause to be included the requirements of paragraph (1) of this Section X in every subcontract, and further agrees to take such action as the contracting agency may direct as a means of enforcing such requirements.

#### **X. CERTIFICATION REGARDING DEBARMENT, SUSPENSION, INELIGIBILITY AND VOLUNTARY EXCLUSION**

This provision is applicable to all Federal-aid construction contracts, design-build contracts, subcontracts, lower-tier subcontracts, purchase orders, lease agreements, consultant contracts or any other covered transaction

requiring FHWA approval or that is estimated to cost \$25,000 or more – as defined in 2 CFR Parts 180 and 1200.

#### **1. Instructions for Certification – First Tier Participants:**

a. By signing and submitting this proposal, the prospective first tier participant is providing the certification set out below.

b. The inability of a person to provide the certification set out below will not necessarily result in denial of participation in this covered transaction. The prospective first tier participant shall submit an explanation of why it cannot provide the certification set out below. The certification or explanation will be considered in connection with the department or agency's determination whether to enter into this transaction. However, failure of the prospective first tier participant to furnish a certification or an explanation shall disqualify such a person from participation in this transaction.

c. The certification in this clause is a material representation of fact upon which reliance was placed when the contracting agency determined to enter into this transaction. If it is later determined that the prospective participant knowingly rendered an erroneous certification, in addition to other remedies available to the Federal Government, the contracting agency may terminate this transaction for cause of default.

d. The prospective first tier participant shall provide immediate written notice to the contracting agency to whom this proposal is submitted if any time the prospective first tier participant learns that its certification was erroneous when submitted or has become erroneous by reason of changed circumstances.

e. The terms "covered transaction," "debarred," "suspended," "ineligible," "participant," "person," "principal," and "voluntarily excluded," as used in this clause, are defined in 2 CFR Parts 180 and 1200. "First Tier Covered Transactions" refers to any covered transaction between a grantee or

subgrantee of Federal funds and a participant (such as the prime or general contract). “Lower Tier Covered Transactions” refers to any covered transaction under a First Tier Covered Transaction (such as subcontracts). “First Tier Participant” refers to the participant who has entered into a covered transaction with a grantee or subgrantee of Federal funds (such as the prime or general contractor). “Lower Tier Participant” refers any participant who has entered into a covered transaction with a First Tier Participant or other Lower Tier Participants (such as subcontractors and suppliers).

f. The prospective first tier participant agrees by submitting this proposal that, should the proposed covered transaction be entered into, it shall not knowingly enter into any lower tier covered transaction with a person who is debarred, suspended, declared ineligible, or voluntarily excluded from participation in this covered transaction, unless authorized by the department or agency entering into this transaction.

g. The prospective first tier participant further agrees by submitting this proposal that it will include the clause titled "Certification Regarding Debarment, Suspension, Ineligibility and Voluntary Exclusion-Lower Tier Covered Transactions," provided by the department or contracting agency, entering into this covered transaction, without modification, in all lower tier covered transactions and in all solicitations for lower tier covered transactions exceeding the \$25,000 threshold.

h. A participant in a covered transaction may rely upon a certification of a prospective participant in a lower tier covered transaction that is not debarred, suspended, ineligible, or voluntarily excluded from the covered transaction, unless it knows that the certification is erroneous. A participant is responsible for ensuring that its principals are not suspended, debarred, or otherwise ineligible to participate in covered transactions. To verify the eligibility of its principals, as well as the eligibility of any lower tier prospective participants, each participant may, but is not required to, check the Excluded Parties List

System website (<https://www.epls.gov/>), which is compiled by the General Services Administration.

i. Nothing contained in the foregoing shall be construed to require the establishment of a system of records in order to render in good faith the certification required by this clause. The knowledge and information of the prospective participant is not required to exceed that which is normally possessed by a prudent person in the ordinary course of business dealings.

j. Except for transactions authorized under paragraph (f) of these instructions, if a participant in a covered transaction knowingly enters into a lower tier covered transaction with a person who is suspended, debarred, ineligible, or voluntarily excluded from participation in this transaction, in addition to other remedies available to the Federal Government, the department or agency may terminate this transaction for cause or default.

\* \* \* \* \*

## **2. Certification Regarding Debarment, Suspension, Ineligibility and Voluntary Exclusion – First Tier Participants:**

a. The prospective first tier participant certifies to the best of its knowledge and belief, that it and its principals:

(1) Are not presently debarred, suspended, proposed for debarment, declared ineligible, or voluntarily excluded from participating in covered transactions by any Federal department or agency;

(2) Have not within a three-year period preceding this proposal been convicted of or had a civil judgment rendered against them for commission of fraud or a criminal offense in connection with obtaining, attempting to obtain, or performing a public (Federal, State or local) transaction or contract under a public transaction; violation of Federal or State antitrust statutes or commission of embezzlement, theft, forgery, bribery, falsification or destruction of records, making false statements, or receiving stolen property;

(3) Are not presently indicted for or otherwise criminally or civilly charged by a governmental entity (Federal, State or local) with commission of any of the offenses enumerated in paragraph (a)(2) of this certification; and

(4) Have not within a three-year period preceding this application/proposal had one or more public transactions (Federal, State or local) terminated for cause or default.

b. Where the prospective participant is unable to certify to any of the statements in this certification, such prospective participant shall attach an explanation to this proposal. |

## **2. Instructions for Certification - Lower Tier Participants:**

(Applicable to all subcontracts, purchase orders and other lower tier transactions requiring prior FHWA approval or estimated to cost \$25,000 or more - 2 CFR Parts 180 and 1200)

a. By signing and submitting this proposal, the prospective lower tier is providing the certification set out below.

b. The certification in this clause is a material representation of fact upon which reliance was placed when this transaction was entered into. If it is later determined that the prospective lower tier participant knowingly rendered an erroneous certification, in addition to other remedies available to the Federal Government, the department, or agency with which this transaction originated may pursue available remedies, including suspension and/or debarment.

c. The prospective lower tier participant shall provide immediate written notice to the person to which this proposal is submitted if at any time the prospective lower tier participant learns that its certification was erroneous by reason of changed circumstances.

d. The terms "covered transaction," "debarred," "suspended," "ineligible," "participant," "person," "principal," and "voluntarily excluded," as used in this clause, are defined in 2 CFR Parts 180 and 1200. You may contact the person to which this proposal

is submitted for assistance in obtaining a copy of those regulations. "First Tier Covered Transactions" refers to any covered transaction between a grantee or subgrantee of Federal funds and a participant (such as the prime or general contract). "Lower Tier Covered Transactions" refers to any covered transaction under a First Tier Covered Transaction (such as subcontracts). "First Tier Participant" refers to the participant who has entered into a covered transaction with a grantee or subgrantee of Federal funds (such as the prime or general contractor). "Lower Tier Participant" refers any participant who has entered into a covered transaction with a First Tier Participant or other Lower Tier Participants (such as subcontractors and suppliers).

e. The prospective lower tier participant agrees by submitting this proposal that, should the proposed covered transaction be entered into, it shall not knowingly enter into any lower tier covered transaction with a person who is debarred, suspended, declared ineligible, or voluntarily excluded from participation in this covered transaction, unless authorized by the department or agency with which this transaction originated.

f. The prospective lower tier participant further agrees by submitting this proposal that it will include this clause titled "Certification Regarding Debarment, Suspension, Ineligibility and Voluntary Exclusion-Lower Tier Covered Transaction," without modification, in all lower tier covered transactions and in all solicitations for lower tier covered transactions exceeding the \$25,000 threshold.

g. A participant in a covered transaction may rely upon a certification of a prospective participant in a lower tier covered transaction that is not debarred, suspended, ineligible, or voluntarily excluded from the covered transaction, unless it knows that the certification is erroneous. A participant is responsible for ensuring that its principals are not suspended, debarred, or otherwise ineligible to participate in covered transactions. To verify the eligibility of its principals, as well as the eligibility of any lower tier prospective

participants, each participant may, but is not required to, check the Excluded Parties List System website (<https://www.epls.gov/>), which is compiled by the General Services Administration.

h. Nothing contained in the foregoing shall be construed to require establishment of a system of records in order to render in good faith the certification required by this clause. The knowledge and information of participant is not required to exceed that which is normally possessed by a prudent person in the ordinary course of business dealings.

i. Except for transactions authorized under paragraph e of these instructions, if a participant in a covered transaction knowingly enters into a lower tier covered transaction with a person who is suspended, debarred, ineligible, or voluntarily excluded from participation in this transaction, in addition to other remedies available to the Federal Government, the department or agency with which this transaction originated may pursue available remedies, including suspension and/or debarment.

\*\*\*\*\*

**Certification Regarding Debarment, Suspension, Ineligibility and Voluntary Exclusion--Lower Tier Participants:**

1. The prospective lower tier participant certifies, by submission of this proposal, that neither it nor its principals is presently debarred, suspended, proposed for debarment, declared ineligible, or voluntarily excluded from participating in covered transactions by any Federal department or agency.

2. Where the prospective lower tier participant is unable to certify to any of the statements in this certification, such prospective participant shall attach an explanation to this proposal.

\*\*\*\*\*

**XI. CERTIFICATION REGARDING USE OF CONTRACT FUNDS FOR LOBBYING**

This provision is applicable to all Federal-aid construction contracts and to all related

subcontracts which exceed \$100,000 (49 CFR 20).

1. The prospective participant certifies, by signing and submitting this bid or proposal, to the best of his or her knowledge and belief, that:

a. No Federal appropriated funds have been paid or will be paid, by or on behalf of the undersigned, to any person for influencing or attempting to influence an officer or employee of any Federal agency, a Member of Congress, an officer or employee of Congress, or an employee of a Member of Congress in connection with the awarding of any Federal contract, the making of any Federal grant, the making of any Federal loan, the entering into of any cooperative agreement, and the extension, continuation, renewal, amendment, or modification of any Federal contract, grant, loan, or cooperative agreement.

b. If any funds other than Federal appropriated funds have been paid or will be paid to any person for influencing or attempting to influence an officer or employee of any Federal agency, a Member of Congress, an officer or employee of Congress, or an employee of a Member of Congress in connection with this Federal contract, grant, loan, or cooperative agreement, the undersigned shall complete and submit Standard Form-LLL, "Disclosure Form to Report Lobbying," in accordance with its instructions.

2. This certification is a material representation of fact upon which reliance was placed when this transaction was made or entered into. Submission of this certification is a prerequisite for making or entering into this transaction imposed by 31 U.S.C. 1352. Any person who fails to file the required certification shall be subject to a civil penalty of not less than \$10,000 and not more than \$100,000 for each such failure.

3. The prospective participant also agrees by submitting its bid or proposal that the participant shall require that the language of this certification be included in all lower tier subcontracts, which exceed \$100,000 and that

all such recipients shall certify and disclose accordingly.

**ATTACHMENT A EMPLOYMENT AND MATERIALS PREFERENCE FOR APPALACHIAN DEVELOPMENT HIGHWAY SYSTEM OR APPALACHIAN LOCAL ACCESS ROAD CONTRACTS**

This provision is applicable to all Federal-aid projects funded under the Appalachian Regional Development Act of 1965.

1. During the performance of this contract, the contractor undertaking to do work which is, or reasonably may be, done as on-site work, shall give preference to qualified persons who regularly reside in the labor area as designated by the DOL wherein the contract work is situated, or the subregion, or the Appalachian counties of the State wherein the contract work is situated, except:

a. To the extent that qualified persons regularly residing in the area are not available.

b. For the reasonable needs of the contractor to employ supervisory or specially experienced personnel necessary to assure an efficient execution of the contract work.

c. For the obligation of the contractor to offer employment to present or former employees as the result of a lawful collective bargaining contract, provided that the number of nonresident persons employed under this subparagraph (1c) shall not exceed 20 percent of the total number of employees employed by the contractor on the contract work, except as provided in subparagraph (4) below.

2. The contractor shall place a job order with the State Employment Service indicating (a) the classifications of the laborers, mechanics and other employees required to perform the contract work, (b) the number of employees required in each classification, (c) the date on which the participant estimates such employees will be required, and (d) any other pertinent information required by the State Employment Service to complete the job order

form. The job order may be placed with the State Employment Service in writing or by telephone. If during the course of the contract work, the information submitted by the contractor in the original job order is substantially modified, the participant shall promptly notify the State Employment Service.

3. The contractor shall give full consideration to all qualified job applicants referred to him by the State Employment Service. The contractor is not required to grant employment to any job applicants who, in his opinion, are not qualified to perform the classification of work required.

4. If, within one week following the placing of a job order by the contractor with the State Employment Service, the State Employment Service is unable to refer any qualified job applicants to the contractor, or less than the number requested, the State Employment Service will forward a certificate to the contractor indicating the unavailability of applicants. Such certificate shall be made a part of the contractor's permanent project records. Upon receipt of this certificate, the contractor may employ persons who do not normally reside in the labor area to fill positions covered by the certificate, notwithstanding the provisions of subparagraph (1c) above.

5. The provisions of 23 CFR 633.207(e) allow the contracting agency to provide a contractual preference for the use of mineral resource materials native to the Appalachian region.

6. The contractor shall include the provisions of Sections 1 through 4 of this Attachment A in every subcontract for work which is, or reasonably may be, done as on-site work.



## **SPECIAL NOTE**

### **NYSDOL STATE PREVAILING WAGE RATES**

The contractor shall ensure that workers are paid the appropriate wages and supplemental (fringe) benefits. Throughout the contract, the Contractor shall obtain and pay workers in accordance with periodic wage rate schedule updates from the NYS Department of Labor (NYSDOL). Wage rate amendments and supplements are available on the NYSDOL website at [www.labor.state.ny.us](http://www.labor.state.ny.us). All changes or clarification of labor classification(s) and applicability of prevailing wage rates shall be obtained in writing from the Office of the Director, NYSDOL Bureau of Public Work.

The NYSDOL prevailing wage rate schedule for this contract has been determined and is available on the internet. The prevailing wage rate schedule is accessed by visiting the NYSDOL website, navigating to the appropriate web page and entering the Prevailing Rate Case No. (PRC#). The PRC# is **2024006574**. The wage rate schedule for this project can be found at the following link: <https://applications.labor.ny.gov/wpp/showFindProject.do?method=showIt>

### **FEDERAL DAVIS BACON WAGES**

Federal Davis Bacon Wages also apply to this project. They may be obtained at <https://sam.gov/wage-determination/NY20240014/1>. A Copy of the prevailing wage rate schedule is also included herein.



Kathy Hochul, Governor

Roberta Reardon, Commissioner

City of Rome  
Chris Cornwell  
80 Wolf Road, Suite 600  
Albany NY 12205

Schedule Year 2023 through 2024  
Date Requested 06/04/2024  
PRC# 2024006574

Location City of Rome  
Project ID# 2650.57  
Project Type Pedestrian and Bicycle improvement project with associated amenities.

### PREVAILING WAGE SCHEDULE FOR ARTICLE 8 PUBLIC WORK PROJECT

Attached is the current schedule(s) of the prevailing wage rates and prevailing hourly supplements for the project referenced above. A unique Prevailing Wage Case Number (PRC#) has been assigned to the schedule(s) for your project.

The schedule is effective from July 2023 through June 2024. All updates, corrections, posted on the 1st business day of each month, and future copies of the annual determination are available on the Department's website [www.labor.ny.gov](http://www.labor.ny.gov). Updated PDF copies of your schedule can be accessed by entering your assigned PRC# at the proper location on the website.

It is the responsibility of the contracting agency or its agent to annex and make part, the attached schedule, to the specifications for this project, when it is advertised for bids and /or to forward said schedules to the successful bidder(s), immediately upon receipt, in order to insure the proper payment of wages.

Please refer to the "General Provisions of Laws Covering Workers on Public Work Contracts" provided with this schedule, for the specific details relating to other responsibilities of the Department of Jurisdiction.

Upon completion or cancellation of this project, enter the required information and mail **OR** fax this form to the office shown at the bottom of this notice, **OR** fill out the electronic version via the NYSDOL website.

#### NOTICE OF COMPLETION / CANCELLATION OF PROJECT

Date Completed: \_\_\_\_\_ Date Cancelled: \_\_\_\_\_

Name & Title of Representative: \_\_\_\_\_

Phone: (518) 457-5589 Fax: (518) 485-1870  
W. Averell Harriman State Office Campus, Bldg. 12, Room 130, Albany, NY 12226



# General Provisions of Laws Covering Workers on Article 8 Public Work Contracts

## Introduction

The Labor Law requires public work contractors and subcontractors to pay laborers, workers, or mechanics employed in the performance of a public work contract not less than the prevailing rate of wage and supplements (fringe benefits) in the locality where the work is performed.

## Responsibilities of the Department of Jurisdiction

A Department of Jurisdiction (Contracting Agency) includes a state department, agency, board or commission; a county, city, town or village; a school district, board of education or board of cooperative educational services; a sewer, water, fire, improvement and other district corporation; a public benefit corporation; and a public authority awarding a public work contract.

The Department of Jurisdiction (Contracting Agency) awarding a public work contract MUST obtain a Prevailing Rate Schedule listing the hourly rates of wages and supplements due the workers to be employed on a public work project. This schedule may be obtained by completing and forwarding a "Request for wage and Supplement Information" form (PW 39) to the Bureau of Public Work. The Prevailing Rate Schedule MUST be included in the specifications for the contract to be awarded and is deemed part of the public work contract.

Upon the awarding of the contract, the law requires that the Department of Jurisdiction (Contracting Agency) furnish the following information to the Bureau: the name and address of the contractor, the date the contract was let and the approximate dollar value of the contract. To facilitate compliance with this provision of the Labor Law, a copy of the Department's "Notice of Contract Award" form (PW 16) is provided with the original Prevailing Rate Schedule.

The Department of Jurisdiction (Contracting Agency) is required to notify the Bureau of the completion or cancellation of any public work project. The Department's PW 200 form is provided for that purpose.

Both the PW 16 and PW 200 forms are available for completion [online](#).

## Hours

No laborer, worker, or mechanic in the employ of a contractor or subcontractor engaged in the performance of any public work project shall be permitted to work more than eight hours in any day or more than five days in any week, except in cases of extraordinary emergency. The contractor and the Department of Jurisdiction (Contracting Agency) may apply to the Bureau of Public Work for a dispensation permitting workers to work additional hours or days per week on a particular public work project.

## Wages and Supplements

The wages and supplements to be paid and/or provided to laborers, workers, and mechanics employed on a public work project shall be not less than those listed in the current Prevailing Rate Schedule for the locality where the work is performed. If a prime contractor on a public work project has not been provided with a Prevailing Rate Schedule, the contractor must notify the Department of Jurisdiction (Contracting Agency) who in turn must request an original Prevailing Rate Schedule from the Bureau of Public Work. Requests may be submitted by: mail to NYSDOL, Bureau of Public Work, State Office Bldg. Campus, Bldg. 12, Rm. 130, Albany, NY 12226; Fax to Bureau of Public Work (518) 485-1870; or electronically at the NYSDOL website [www.labor.ny.gov](http://www.labor.ny.gov).

Upon receiving the original schedule, the Department of Jurisdiction (Contracting Agency) is REQUIRED to provide complete copies to all prime contractors who in turn MUST, by law, provide copies of all applicable county schedules to each subcontractor and obtain from each subcontractor, an affidavit certifying such schedules were received. If the original schedule expired, the contractor may obtain a copy of the new annual determination from the NYSDOL website [www.labor.ny.gov](http://www.labor.ny.gov).

The Commissioner of Labor makes an annual determination of the prevailing rates. This determination is in effect from July 1st through June 30th of the following year. The annual determination is available on the NYSDOL website [www.labor.ny.gov](http://www.labor.ny.gov).

## Payrolls and Payroll Records

Every contractor and subcontractor MUST keep original payrolls or transcripts subscribed and affirmed as true under penalty of perjury. As per Article 6 of the Labor law, contractors and subcontractors are required to establish, maintain, and preserve for not less than six (6) years, contemporaneous, true, and accurate payroll records. At a minimum, payrolls must show the following information for each person employed on a public work project: Name, Address, Last 4 Digits of Social Security Number, Classification(s) in which the worker was employed, Hourly wage rate(s) paid, Supplements paid or provided, and Daily and weekly number of hours worked in each classification.

The filing of payrolls to the Department of Jurisdiction is a condition of payment. Every contractor and subcontractor shall submit to the Department of Jurisdiction (Contracting Agency), within thirty (30) days after issuance of its first payroll and every thirty (30) days thereafter, a transcript of the original payrolls, subscribed and affirmed as true under penalty of perjury. The Department of Jurisdiction (Contracting Agency) shall collect, review for facial validity, and maintain such payrolls.

In addition, the Commissioner of Labor may require contractors to furnish, with ten (10) days of a request, payroll records sworn to as their validity and accuracy for public work and private work. Payroll records include, but are not limited to time cards, work description sheets, proof that supplements were provided, cancelled payroll checks and payrolls. Failure to provide the requested information within the allotted ten (10) days will result in the withholding of up to 25% of the contract, not to exceed \$100,000.00. If the contractor or subcontractor does not maintain a place of business in New York State and the amount of the contract exceeds \$25,000.00, payroll records and certifications must be kept on the project worksite.

The prime contractor is responsible for any underpayments of prevailing wages or supplements by any subcontractor.

All contractors or their subcontractors shall provide to their subcontractors a copy of the Prevailing Rate Schedule specified in the public work contract as well as any subsequently issued schedules. A failure to provide these schedules by a contractor or subcontractor is a violation of Article 8, Section 220-a of the Labor Law.

All subcontractors engaged by a public work project contractor or its subcontractor, upon receipt of the original schedule and any subsequently issued schedules, shall provide to such contractor a verified statement attesting that the subcontractor has received the Prevailing Rate Schedule and will pay or provide the applicable rates of wages and supplements specified therein. (See NYS Labor Laws, Article 8 . Section 220-a).

### **Determination of Prevailing Wage and Supplement Rate Updates Applicable to All Counties**

The wages and supplements contained in the annual determination become effective July 1st whether or not the new determination has been received by a given contractor. Care should be taken to review the rates for obvious errors. Any corrections should be brought to the Department's attention immediately. It is the responsibility of the public work contractor to use the proper rates. If there is a question on the proper classification to be used, please call the district office located nearest the project. Any errors in the annual determination will be corrected and posted to the NYS DOL website on the first business day of each month. Contractors are responsible for paying these updated rates as well, retroactive to July 1st.

When you review the schedule for a particular occupation, your attention should be directed to the dates above the column of rates. These are the dates for which a given set of rates is effective. To the extent possible, the Department posts rates in its possession that cover periods of time beyond the July 1st to June 30th time frame covered by a particular annual determination. Rates that extend beyond that instant time period are informational ONLY and may be updated in future annual determinations that actually cover the then appropriate July 1st to June 30th time period.

### **Withholding of Payments**

When a complaint is filed with the Commissioner of Labor alleging the failure of a contractor or subcontractor to pay or provide the prevailing wages or supplements, or when the Commissioner of Labor believes that unpaid wages or supplements may be due, payments on the public work contract shall be withheld from the prime contractor in a sufficient amount to satisfy the alleged unpaid wages and supplements, including interest and civil penalty, pending a final determination.

When the Bureau of Public Work finds that a contractor or subcontractor on a public work project failed to pay or provide the requisite prevailing wages or supplements, the Bureau is authorized by Sections 220-b and 235.2 of the Labor Law to so notify the financial officer of the Department of Jurisdiction (Contracting Agency) that awarded the public work contract. Such officer MUST then withhold or cause to be withheld from any payment due the prime contractor on account of such contract the amount indicated by the Bureau as sufficient to satisfy the unpaid wages and supplements, including interest and any civil penalty that may be assessed by the Commissioner of Labor. The withholding continues until there is a final determination of the underpayment by the Commissioner of Labor or by the court in the event a legal proceeding is instituted for review of the determination of the Commissioner of Labor.

The Department of Jurisdiction (Contracting Agency) shall comply with this order of the Commissioner of Labor or of the court with respect to the release of the funds so withheld.

### **Summary of Notice Posting Requirements**

The current Prevailing Rate Schedule must be posted in a prominent and accessible place on the site of the public work project. The prevailing wage schedule must be encased in, or constructed of, materials capable of withstanding adverse weather conditions and be titled "PREVAILING RATE OF WAGES" in letters no smaller than two (2) inches by two (2) inches.

The "[Public Work Project](#)" notice must be posted at the beginning of the performance of every public work contract, on each job site.

Every employer providing workers. compensation insurance and disability benefits must post notices of such coverage in the format prescribed by the Workers. Compensation Board in a conspicuous place on the jobsite.

Every employer subject to the NYS Human Rights Law must conspicuously post at its offices, places of employment, or employment training centers, notices furnished by the State Division of Human Rights.

Employers liable for contributions under the Unemployment Insurance Law must conspicuously post on the jobsite notices furnished by the NYS Department of Labor.

## **Apprentices**

Employees cannot be paid apprentice rates unless they are individually registered in a program registered with the NYS Commissioner of Labor. The allowable ratio of apprentices to journeyworkers in any craft classification can be no greater than the statewide building trade ratios promulgated by the Department of Labor and included with the Prevailing Rate Schedule. An employee listed on a payroll as an apprentice who is not registered as above or is performing work outside the classification of work for which the apprentice is indentured, must be paid the prevailing journeyworker's wage rate for the classification of work the employee is actually performing.

NYSDOL Labor Law, Article 8, Section 220-3, require that only apprentices individually registered with the NYS Department of Labor may be paid apprenticeship rates on a public work project. No other Federal or State Agency of office registers apprentices in New York State.

Persons wishing to verify the apprentice registration of any person must do so in writing by mail, to the NYSDOL Office of Employability Development / Apprenticeship Training, State Office Bldg. Campus, Bldg. 12, Albany, NY 12226 or by Fax to NYSDOL Apprenticeship Training (518) 457-7154. All requests for verification must include the name and social security number of the person for whom the information is requested.

The only conclusive proof of individual apprentice registration is written verification from the NYSDOL Apprenticeship Training Albany Central office. Neither Federal nor State Apprenticeship Training offices outside of Albany can provide conclusive registration information.

It should be noted that the existence of a registered apprenticeship program is not conclusive proof that any person is registered in that program. Furthermore, the existence or possession of wallet cards, identification cards, or copies of state forms is not conclusive proof of the registration of any person as an apprentice.

## **Interest and Penalties**

In the event that an underpayment of wages and/or supplements is found:

- Interest shall be assessed at the rate then in effect as prescribed by the Superintendent of Banks pursuant to section 14-a of the Banking Law, per annum from the date of underpayment to the date restitution is made.
- A Civil Penalty may also be assessed, not to exceed 25% of the total of wages, supplements, and interest due.

## **Debarment**

Any contractor or subcontractor and/or its successor shall be ineligible to submit a bid on or be awarded any public work contract or subcontract with any state, municipal corporation or public body for a period of five (5) years when:

- Two (2) willful determinations have been rendered against that contractor or subcontractor and/or its successor within any consecutive six (6) year period.
- There is any willful determination that involves the falsification of payroll records or the kickback of wages or supplements.

## **Criminal Sanctions**

Willful violations of the Prevailing Wage Law (Article 8 of the Labor Law) may be a felony punishable by fine or imprisonment of up to 15 years, or both.

## **Discrimination**

No employee or applicant for employment may be discriminated against on account of age, race, creed, color, national origin, sex, disability or marital status.

No contractor, subcontractor nor any person acting on its behalf, shall by reason of race, creed, color, disability, sex or national origin discriminate against any citizen of the State of New York who is qualified and available to perform the work to which the employment relates (NYS Labor Law, Article 8, Section 220-e(a)).

No contractor, subcontractor, nor any person acting on its behalf, shall in any manner, discriminate against or intimidate any employee on account of race, creed, color, disability, sex, or national origin (NYS Labor Law, Article 8, Section 220-e(b)).

The Human Rights Law also prohibits discrimination in employment because of age, marital status, or religion.

There may be deducted from the amount payable to the contractor under the contract a penalty of \$50.00 for each calendar day during which such person was discriminated against or intimidated in violation of the provision of the contract (NYS Labor Law, Article 8, Section 220-e(c) ).

The contract may be cancelled or terminated by the State or municipality. All monies due or to become due thereunder may be forfeited for a second or any subsequent violation of the terms or conditions of the anti-discrimination sections of the contract (NYS Labor Law, Article 8, Section 220-e(d) ).

Every employer subject to the New York State Human Rights Law must conspicuously post at its offices, places of employment, or employment training centers notices furnished by the State Division of Human Rights.

### **Workers' Compensation**

In accordance with Section 142 of the State Finance Law, the contractor shall maintain coverage during the life of the contract for the benefit of such employees as required by the provisions of the New York State Workers' Compensation Law.

A contractor who is awarded a public work contract must provide proof of workers' compensation coverage prior to being allowed to begin work.

The insurance policy must be issued by a company authorized to provide workers' compensation coverage in New York State. Proof of coverage must be on form C-105.2 (Certificate of Workers' Compensation Insurance) and must name this agency as a certificate holder.

If New York State coverage is added to an existing out-of-state policy, it can only be added to a policy from a company authorized to write workers' compensation coverage in this state. The coverage must be listed under item 3A of the information page.

The contractor must maintain proof that subcontractors doing work covered under this contract secured and maintained a workers' compensation policy for all employees working in New York State.

Every employer providing worker's compensation insurance and disability benefits must post notices of such coverage in the format prescribed by the Workers' Compensation Board in a conspicuous place on the jobsite.

### **Unemployment Insurance**

Employers liable for contributions under the Unemployment Insurance Law must conspicuously post on the jobsite notices furnished by the New York State Department of Labor.



Kathy Hochul, Governor

Roberta Reardon, Commissioner

City of Rome  
Chris Cornwell  
80 Wolf Road, Suite 600  
Albany NY 12205

Schedule Year 2023 through 2024  
Date Requested 06/04/2024  
PRC# 2024006574

Location City of Rome  
Project ID# 2650.57  
Project Type Pedestrian and Bicycle improvement project with associated amenities.

### Notice of Contract Award

New York State Labor Law, Article 8, Section 220.3a requires that certain information regarding the awarding of public work contracts, be furnished to the Commissioner of Labor. One "Notice of Contract Award" (PW 16, which may be photocopied), **MUST** be completed for **EACH** prime contractor on the above referenced project.

Upon notifying the successful bidder(s) of this contract, enter the required information and mail **OR** fax this form to the office shown at the bottom of this notice, **OR** fill out the electronic version via the NYSDOL website.

### Contractor Information

All information must be supplied

Federal Employer Identification Number: _____		
Name: _____		
Address: _____ _____		
City: _____	State: _____	Zip: _____
Amount of Contract: \$ _____	Contract Type:	
Approximate Starting Date: ____/____/____	<input type="checkbox"/> (01) General Construction	
Approximate Completion Date: ____/____/____	<input type="checkbox"/> (02) Heating/Ventilation	
	<input type="checkbox"/> (03) Electrical	
	<input type="checkbox"/> (04) Plumbing	
	<input type="checkbox"/> (05) Other : _____	

Phone: (518) 457-5589 Fax: (518) 485-1870  
W. Averell Harriman State Office Campus, Bldg. 12, Room 130, Albany, NY 12226



## **Social Security Numbers on Certified Payrolls:**

The Department of Labor is cognizant of the concerns of the potential for misuse or inadvertent disclosure of social security numbers. Identity theft is a growing problem and we are sympathetic to contractors' concern regarding inclusion of this information on payrolls if another identifier will suffice.

For these reasons, the substitution of the use of the last four digits of the social security number on certified payrolls submitted to contracting agencies on public work projects is now acceptable to the Department of Labor. This change does not affect the Department's ability to request and receive the entire social security number from employers during its public work/ prevailing wage investigations.

## **Construction Industry Fair Play Act: Required Posting for Labor Law Article 25-B § 861-d**

Construction industry employers must post the "Construction Industry Fair Play Act" notice in a prominent and accessible place on the job site. Failure to post the notice can result in penalties of up to \$1,500 for a first offense and up to \$5,000 for a second offense. The posting is included as part of this wage schedule. Additional copies may be obtained from the NYS DOL website, <https://dol.ny.gov/public-work-and-prevailing-wage>

If you have any questions concerning the Fair Play Act, please call the State Labor Department toll-free at 1-866-435-1499 or email us at: [dol.misclassified@labor.ny.gov](mailto:dol.misclassified@labor.ny.gov) .

## **Worker Notification: (Labor Law §220, paragraph a of subdivision 3-a)**

### **Effective June 23, 2020**

This provision is an addition to the existing wage rate law, Labor Law §220, paragraph a of subdivision 3-a. It requires contractors and subcontractors to provide written notice to all laborers, workers or mechanics of the *prevailing wage and supplement rate* for their particular job classification *on each pay stub*\*. It also requires contractors and subcontractors to *post a notice* at the beginning of the performance of every public work contract *on each job site* that includes the telephone number and address for the Department of Labor and a statement informing laborers, workers or mechanics of their right to contact the Department of Labor if he/she is not receiving the proper prevailing rate of wages and/or supplements for his/her job classification. The required notification will be provided with each wage schedule, may be downloaded from our website [www.labor.ny.gov](http://www.labor.ny.gov) or be made available upon request by contacting the Bureau of Public Work at 518-457-5589. \*In the event the required information will not fit on the pay stub, an accompanying sheet or attachment of the information will suffice.

(12.20)

**To all State Departments, Agency Heads and Public Benefit Corporations  
IMPORTANT NOTICE REGARDING PUBLIC WORK ENFORCEMENT FUND**

**Budget Policy & Reporting Manual**

**B-610**

**Public Work Enforcement Fund**

*effective date December 7, 2005*

---

**1. Purpose and Scope:**

This Item describes the Public Work Enforcement Fund (the Fund, PWEF) and its relevance to State agencies and public benefit corporations engaged in construction or reconstruction contracts, maintenance and repair, and announces the recently-enacted increase to the percentage of the dollar value of such contracts that must be deposited into the Fund. This item also describes the roles of the following entities with respect to the Fund:

- New York State Department of Labor (DOL),
- The Office of the State of Comptroller (OSC), and
- State agencies and public benefit corporations.

**2. Background and Statutory References:**

DOL uses the Fund to enforce the State's Labor Law as it relates to contracts for construction or reconstruction, maintenance and repair, as defined in subdivision two of Section 220 of the Labor Law. State agencies and public benefit corporations participating in such contracts are required to make payments to the Fund.

Chapter 511 of the Laws of 1995 (as amended by Chapter 513 of the Laws of 1997, Chapter 655 of the Laws of 1999, Chapter 376 of the Laws of 2003 and Chapter 407 of the Laws of 2005) established the Fund.

**3. Procedures and Agency Responsibilities:**

The Fund is supported by transfers and deposits based on the value of contracts for construction and reconstruction, maintenance and repair, as defined in subdivision two of Section 220 of the Labor Law, into which all State agencies and public benefit corporations enter.

Chapter 407 of the Laws of 2005 increased the amount required to be provided to this fund to .10 of one-percent of the total cost of each such contract, to be calculated at the time agencies or public benefit corporations enter into a new contract or if a contract is amended. The provisions of this bill became effective August 2, 2005.

**To all State Departments, Agency Heads and Public Benefit Corporations  
IMPORTANT NOTICE REGARDING PUBLIC WORK ENFORCEMENT FUND**

OSC will report to DOL on all construction-related ("D") contracts approved during the month, including contract amendments, and then DOL will bill agencies the appropriate assessment monthly. An agency may then make a determination if any of the billed contracts are exempt and so note on the bill submitted back to DOL. For any instance where an agency is unsure if a contract is or is not exempt, they can call the Bureau of Public Work at the number noted below for a determination. Payment by check or journal voucher is due to DOL within thirty days from the date of the billing. DOL will verify the amounts and forward them to OSC for processing.

For those contracts which are not approved or administered by the Comptroller, monthly reports and payments for deposit into the Public Work Enforcement Fund must be provided to the Administrative Finance Bureau at the DOL within 30 days of the end of each month or on a payment schedule mutually agreed upon with DOL.

Reports should contain the following information:

- Name and billing address of State agency or public benefit corporation;
- State agency or public benefit corporation contact and phone number;
- Name and address of contractor receiving the award;
- Contract number and effective dates;
- Contract amount and PWEF assessment charge (if contract amount has been amended, reflect increase or decrease to original contract and the adjustment in the PWEF charge); and
- Brief description of the work to be performed under each contract.

Checks and Journal Vouchers, payable to the "New York State Department of Labor" should be sent to:

Department of Labor  
Administrative Finance Bureau-PWEF Unit  
Building 12, Room 464  
State Office Campus  
Albany, NY 12226

Any questions regarding billing should be directed to NYSDOL's Administrative Finance Bureau-PWEF Unit at (518) 457-3624 and any questions regarding Public Work Contracts should be directed to the Bureau of Public Work at (518) 457-5589.

Required Notice under Article 25-B of the Labor Law

**Attention All Employees, Contractors and Subcontractors:  
You are Covered by the Construction Industry Fair Play Act**

**The law says that you are an employee unless:**

- You are free from direction and control in performing your job, **and**
- You perform work that is not part of the usual work done by the business that hired you, **and**
- You have an independently established business.

Your employer cannot consider you to be an independent contractor unless all three of these facts apply to your work.

**It is against the law for an employer to misclassify employees as independent contractors or pay employees off the books.**

**Employee Rights:** If you are an employee, you are entitled to state and federal worker protections. These include:

- Unemployment Insurance benefits, if you are unemployed through no fault of your own, able to work, and otherwise qualified,
- Workers' compensation benefits for on-the-job injuries,
- Payment for wages earned, minimum wage, and overtime (under certain conditions),
- Prevailing wages on public work projects,
- The provisions of the National Labor Relations Act, and
- A safe work environment.

It is a violation of this law for employers to retaliate against anyone who asserts their rights under the law. Retaliation subjects an employer to civil penalties, a private lawsuit or both.

**Independent Contractors:** If you are an independent contractor, **you must pay all taxes and Unemployment Insurance contributions required by New York State and Federal Law.**

**Penalties** for paying workers off the books or improperly treating employees as independent contractors:

- **Civil Penalty**                      First offense: Up to \$2,500 per employee  
                                                    Subsequent offense(s): Up to \$5,000 per employee
- **Criminal Penalty**                First offense: Misdemeanor - up to 30 days in jail, up to a \$25,000 fine and debarment from performing public work for up to one year.  
                                                    Subsequent offense(s): Misdemeanor - up to 60 days in jail or up to a \$50,000 fine and debarment from performing public work for up to 5 years.

**If you have questions about your employment status or believe that your employer may have violated your rights and you want to file a complaint, call the Department of Labor at (866) 435-1499 or send an email to [dol.misclassified@labor.ny.gov](mailto:dol.misclassified@labor.ny.gov). All complaints of fraud and violations are taken seriously. You can remain anonymous.**



# Attention Employees

## THIS IS A: **PUBLIC WORK PROJECT**

If you are employed on this project as a **worker, laborer, or mechanic** you are entitled to receive the **prevailing wage and supplements rate** for the classification at which you are working.

Your pay stub and wage notice received upon hire must clearly state your wage rate and supplement rate.

Chapter 629 of the Labor Laws of 2007:

**These wages are set by law and must be posted at the work site. They can also be found at:**  
**<https://dol.ny.gov/bureau-public-work>**



If you feel that you have not received proper wages or benefits, please call our nearest office.\*

Albany	(518) 457-2744	Patchogue	(631) 687-4882
Binghamton	(607) 721-8005	Rochester	(585) 258-4505
Buffalo	(716) 847-7159	Syracuse	(315) 428-4056
Garden City	(516) 228-3915	Utica	(315) 793-2314
New York City	(212) 932-2419	White Plains	(914) 997-9507
Newburgh	(845) 568-5287		

\* For New York City government agency construction projects, please contact the Office of the NYC Comptroller at (212) 669-4443, or [www.comptroller.nyc.gov](http://www.comptroller.nyc.gov) – click on Bureau of Labor Law.

Contractor Name: \_\_\_\_\_

Project Location: \_\_\_\_\_

## Requirements for OSHA 10 Compliance

Article 8 §220-h requires that when the advertised specifications, for every contract for public work, is \$250,000.00 or more the contract must contain a provision requiring that every worker employed in the performance of a public work contract shall be certified as having completed an OSHA 10 safety training course. The clear intent of this provision is to require that all employees of public work contractors, required to be paid prevailing rates, receive such training "prior to the performing any work on the project."

### The Bureau will enforce the statute as follows:

All contractors and sub contractors must attach a copy of proof of completion of the OSHA 10 course to the first certified payroll submitted to the contracting agency and on each succeeding payroll where any new or additional employee is first listed.

Proof of completion may include but is not limited to:

- Copies of bona fide course completion card (*Note: Completion cards do not have an expiration date.*)
- Training roster, attendance record or other documentation from the certified trainer pending the issuance of the card.
- Other valid proof

\*\*A certification by the employer attesting that all employees have completed such a course is not sufficient proof that the course has been completed.

Any questions regarding this statute may be directed to the New York State Department of Labor, Bureau of Public Work at 518-457-5589.

## WICKS

Public work projects are subject to the Wicks Law requiring separate specifications and bidding for the plumbing, heating and electrical work, when the total project's threshold is \$3 million in Bronx, Kings, New York, Queens and, Richmond counties; \$1.5 million in Nassau, Suffolk and Westchester counties; and \$500,000 in all other counties.

For projects below the monetary threshold, bidders must submit a sealed list naming each subcontractor for the plumbing, HVAC and electrical and the amount to be paid to each. The list may not be changed unless the public owner finds a legitimate construction need, including a change in specifications or costs or the use of a Project Labor Agreement (PLA), and must be open to public inspection.

Allows the state and local agencies and authorities to waive the Wicks Law and use a PLA if it will provide the best work at the lowest possible price. If a PLA is used, all contractors shall participate in apprentice training programs in the trades of work it employs that have been approved by the Department of Labor (DOL) for not less than three years. They shall also have at least one graduate in the last three years and use affirmative efforts to retain minority apprentices. PLA's would be exempt from Wicks, but deemed to be public work subject to prevailing wage enforcement.

The Commissioner of Labor shall have the power to enforce separate specification requirements on projects, and may issue stop-bid orders against public owners for non-compliance.

Other new monetary thresholds, and similar sealed bidding for non-Wicks projects, would apply to certain public authorities including municipal housing authorities, NYC Construction Fund, Yonkers Educational Construction Fund, NYC Municipal Water Finance Authority, Buffalo Municipal Water Finance Authority, Westchester County Health Care Association, Nassau County Health Care Corp., Clifton-Fine Health Care Corp., Erie County Medical Center Corp., NYC Solid Waste Management Facilities, and the Dormitory Authority.

Contractors must pay subcontractors within a 7 days period.

(07.19)

## Introduction to the Prevailing Rate Schedule

### Information About Prevailing Rate Schedule

This information is provided to assist you in the interpretation of particular requirements for each classification of worker contained in the attached Schedule of Prevailing Rates.

#### Classification

It is the duty of the Commissioner of Labor to make the proper classification of workers taking into account whether the work is heavy and highway, building, sewer and water, tunnel work, or residential, and to make a determination of wages and supplements to be paid or provided. It is the responsibility of the public work contractor to use the proper rate. If there is a question on the proper classification to be used, please call the district office located nearest the project. District office locations and phone numbers are listed below.

Prevailing Wage Schedules are issued separately for "General Construction Projects" and "Residential Construction Projects" on a county-by-county basis.

General Construction Rates apply to projects such as: Buildings, Heavy & Highway, and Tunnel and Water & Sewer rates.

Residential Construction Rates generally apply to construction, reconstruction, repair, alteration, or demolition of one family, two family, row housing, or rental type units intended for residential use.

Some rates listed in the Residential Construction Rate Schedule have a very limited applicability listed along with the rate. Rates for occupations or locations not shown on the residential schedule must be obtained from the General Construction Rate Schedule. Please contact the local Bureau of Public Work office before using Residential Rate Schedules, to ensure that the project meets the required criteria.

#### Payrolls and Payroll Records

Contractors and subcontractors are required to establish, maintain, and preserve for not less than six (6) years, contemporaneous, true, and accurate payroll records.

Every contractor and subcontractor shall submit to the Department of Jurisdiction (Contracting Agency), within thirty (30) days after issuance of its first payroll and every thirty (30) days thereafter, a transcript of the original payrolls, subscribed and affirmed as true under penalty of perjury.

#### Paid Holidays

Paid Holidays are days for which an eligible employee receives a regular day's pay, but is not required to perform work. If an employee works on a day listed as a paid holiday, this remuneration is in addition to payment of the required prevailing rate for the work actually performed.

#### Overtime

At a minimum, all work performed on a public work project in excess of eight hours in any one day or more than five days in any workweek is overtime. However, the specific overtime requirements for each trade or occupation on a public work project may differ. Specific overtime requirements for each trade or occupation are contained in the prevailing rate schedules.

Overtime holiday pay is the premium pay that is required for work performed on specified holidays. It is only required where the employee actually performs work on such holidays.

The applicable holidays are listed under HOLIDAYS: OVERTIME. The required rate of pay for these covered holidays can be found in the OVERTIME PAY section listings for each classification.

#### Supplemental Benefits

Particular attention should be given to the supplemental benefit requirements. Although in most cases the payment or provision of supplements is straight time for all hours worked, some classifications require the payment or provision of supplements, or a portion of the supplements, to be paid or provided at a premium rate for premium hours worked. Supplements may also be required to be paid or provided on paid holidays, regardless of whether the day is worked. The Overtime Codes and Notes listed on the particular wage classification will indicate these conditions as required.

#### Effective Dates

When you review the schedule for a particular occupation, your attention should be directed to the dates above the column of rates. These are the dates for which a given set of rates is effective. The rate listed is valid until the next effective rate change or until the new annual determination which takes effect on July 1 of each year. All contractors and subcontractors are required to pay the current prevailing rates of wages and supplements. If you have any questions please contact the Bureau of Public Work or visit the New York State Department of Labor website ([www.labor.ny.gov](http://www.labor.ny.gov)) for current wage rate information.

#### Apprentice Training Ratios

The following are the allowable ratios of registered Apprentices to Journey-workers.

For example, the ratio 1:1,1:3 indicates the allowable initial ratio is one Apprentice to one Journeyworker. The Journeyworker must be in place on the project before an Apprentice is allowed. Then three additional Journeyworkers are needed before a second Apprentice is allowed. The last ratio repeats indefinitely. Therefore, three more Journeyworkers must be present before a third Apprentice can be hired, and so on.

Please call Apprentice Training Central Office at (518) 457-6820 if you have any questions.

Title (Trade)	Ratio
Boilermaker (Construction)	1:1,1:4
Boilermaker (Shop)	1:1,1:3
Carpenter (Bldg.,H&H, Pile Driver/Dockbuilder)	1:1,1:4
Carpenter (Residential)	1:1,1:3
Electrical (Outside) Lineman	1:1,1:2
Electrician (Inside)	1:1,1:3
Elevator/Escalator Construction & Modernizer	1:1,1:2
Glazier	1:1,1:3
Insulation & Asbestos Worker	1:1,1:3
Iron Worker	1:1,1:4
Laborer	1:1,1:3
Mason	1:1,1:4
Millwright	1:1,1:4
Op Engineer	1:1,1:5
Painter	1:1,1:3
Plumber & Steamfitter	1:1,1:3
Roofer	1:1,1:2
Sheet Metal Worker	1:1,1:3
Sprinkler Fitter	1:1,1:2

If you have any questions concerning the attached schedule or would like additional information, please contact the nearest BUREAU of PUBLIC WORK District Office or write to:

New York State Department of Labor  
 Bureau of Public Work  
 State Office Campus, Bldg. 12  
 Albany, NY 12226

District Office Locations:	Telephone #	FAX #
Bureau of Public Work - Albany	518-457-2744	518-485-0240
Bureau of Public Work - Binghamton	607-721-8005	607-721-8004
Bureau of Public Work - Buffalo	716-847-7159	716-847-7650
Bureau of Public Work - Garden City	516-228-3915	516-794-3518
Bureau of Public Work - Newburgh	845-568-5287	845-568-5332
Bureau of Public Work - New York City	212-932-2419	212-775-3579
Bureau of Public Work - Patchogue	631-687-4882	631-687-4902
Bureau of Public Work - Rochester	585-258-4505	585-258-4708
Bureau of Public Work - Syracuse	315-428-4056	315-428-4671
Bureau of Public Work - Utica	315-793-2314	315-793-2514
Bureau of Public Work - White Plains	914-997-9507	914-997-9523
Bureau of Public Work - Central Office	518-457-5589	518-485-1870



**Oneida County General Construction**

**Boilermaker** **06/01/2024**

**JOB DESCRIPTION** Boilermaker **DISTRICT 7**

**ENTIRE COUNTIES**  
 Cayuga, Clinton, Cortland, Franklin, Jefferson, Lewis, Madison, Oneida, Onondaga, Oswego, Seneca, St. Lawrence, Tompkins

**WAGES**

Per hour:	07/01/2023	01/01/2024
Boilermaker	\$ 36.98	\$ 37.98

**SUPPLEMENTAL BENEFITS**

Per hour:		
Journeyman	\$ 26.31*	\$ 26.62*
	+ 1.48	+ 1.48

\*This portion of the benefits subject to the same premium rate as shown for overtime wages.

**OVERTIME PAY**  
 See (B, E, Q) on OVERTIME PAGE

**HOLIDAY**  
 Paid: See (1) on HOLIDAY PAGE  
 Overtime: See (5, 6, 15, 25) on HOLIDAY PAGE  
 NOTE: When a holiday falls on Sunday, the day observed by the State or Nation shall be observed. When Christmas Day and New Year's fall on Saturday, Friday will be observed as the holiday.

**REGISTERED APPRENTICES**  
 WAGES per hour: Six month terms at the following percentage of Journeyman's wage.

1st	2nd	3rd	4th	5th	6th	7th	8th
65%	65%	70%	75%	80%	85%	90%	95%

SUPPLEMENTAL BENEFITS per hour:

\$ 19.58*	\$ 19.58*	\$ 20.54*	\$ 21.49*	\$ 22.44*	\$ 23.42*	\$ 24.40*	\$ 25.35*
+ 1.48	+ 1.48	+ 1.48	+ 1.48	+ 1.48	+ 1.48	+ 1.48	+ 1.48

\*This portion of the benefits subject to the same premium rate as shown for overtime wages.

7-175

**Carpenter - Building** **06/01/2024**

**JOB DESCRIPTION** Carpenter - Building **DISTRICT 7**

**ENTIRE COUNTIES**  
 Herkimer, Madison, Oneida

**WAGES**

Per hour:	07/01/2023	07/01/2024	07/01/2025
		Additional	Additional
Carpenter	\$ 29.95	\$ 1.30	\$ 1.30
Floor Coverer	29.95	1.30	1.30
Carpet Layer	29.95	1.30	1.30
Drywall	29.95	1.30	1.30
Diver - Wet Day	61.25	--	--
Diver - Dry Day	30.95	1.30	1.30
Dive Tender	30.95	1.30	1.30

NOTE ADDITIONAL AMOUNTS PAID FOR THE FOLLOWING WORK LISTED BELOW (per hour worked):

- Pile Drivers/Dock Builders shall receive \$0.25 per hour over the Journeyman's rate of pay when performing piledriving/dock building work.
- Certified Welders shall receive \$1.00 per hour over the Journeyman's rate of pay when the employee is required to be certified and performs DOT or ABS specified welding work.
- When an employee performs work within a contaminated area on a State and/or Federally designated hazardous waste site, and where relevant State and/or Federal regulations require employees to be furnished and use or wear required forms of personal protection, then the employee shall receive his regular hourly rate plus \$1.50 per hour.
- Depth pay for Divers based upon deepest depth on the day of the dive (per diem payment):
  - 0' to 80' no additional fee
  - 81' to 100' additional \$.50 per foot

- 101' to 150' additional \$0.75 per foot
- 151' and deeper additional \$1.25 per foot
- Penetration pay for Divers based upon deepest penetration on the day of the dive (per diem payment):
  - 0' to 50' no additional fee
  - 51' to 100' additional \$.75 per foot
  - 101' and deeper additional \$1.00 per foot
- Diver rates applies to all hours worked on dive day.

**SHIFT WORK**

On Agency/Owner mandated shift work, the following rates will be applicable:

- 1st Shift - Regular Rate
- 2nd Shift - Premium of 7% of base wage per hour
- 3rd Shift - Premium of 14% of base wage per hour

Shift work shall be defined as implementing at least two (2) shifts in a twenty-four (24) consecutive hour period. Shift work must be for a minimum of three (3) consecutive days.

NOTE - The "Employer Registration" (30.1) use of a '4 Day/10 Hour Work schedules' will no longer be accepted or processed. All registered projects prior to June 30, 2023 will expire within the granted time frame.

For Pre-Registered Projects Four (4), Ten (10) hour days may be worked at straight time during a week, Monday thru Thursday. Friday may be used as a make-up day. Tuesday thru Friday may be worked with no make-up day. For further clarification contact your local Bureau Office.

**SUPPLEMENTAL BENEFITS**

Per hour:

Journeyman \$ 21.29

**OVERTIME PAY**

See (B, E, E2, Q) on OVERTIME PAGE

**HOLIDAY**

Paid: See (1) on HOLIDAY PAGE  
Overtime: See (5, 6) on HOLIDAY PAGE

NOTE: Any holiday which occurs on Sunday shall be observed the following Monday. If Christmas falls on a Saturday, it shall be observed on the prior Friday.

**REGISTERED APPRENTICES**

**CARPENTER APPRENTICES**

Wages per hour (1300 hour terms at the following percentage of Journeyman's base wage):

1st	2nd	3rd	4th
65%	70%	75%	80%

Supplemental Benefits per hour:

\$ 12.55	\$ 12.56	\$ 15.16	\$ 15.16
----------	----------	----------	----------

**PILEDRIVER/DOCK BUILDER APPRENTICES**

Wages per hour (1300 hour terms at the following percentage of Journeyman's base wage):

1st	2nd	3rd	4th
65%*	70%*	75%*	80%*

\*Pile Driving/Dock Builder apprentices shall receive an additional \$0.25 per hour worked when performing piledriving/dock building work.

Supplemental Benefits per hour:

\$ 12.55	\$ 12.56	\$ 15.16	\$ 15.16
----------	----------	----------	----------

**LINOLEUM, RESILIENT TILE, AND CARPET LAYER APPRENTICES**

Wages per hour (1300 hour terms at the following percentage of Journeyman's base wage):

1st	2nd	3rd	4th
65%	70%	75%	80%

Supplemental Benefits per hour:

\$ 12.55	\$ 12.56	\$ 15.16	\$ 15.16
----------	----------	----------	----------

**ADDITIONAL AMOUNTS PAID PER HOUR WORKED TO APPRENTICES FOR SPECIFIC TYPES OF WORK PERFORMED:**

- Certified Welders shall receive \$1.00 per hour over the apprentices rate of pay when the apprentice is required to be certified and performs DOT or ABS specified welding work.
- When an apprentice performs work within a contaminated area on a State and/or Federally designated hazardous waste site, and where relevant State and/or Federal regulations require the apprentice to be furnished and use or wear required forms of personal protection, then the apprentice shall receive his regular hourly rate plus \$1.50 per hour.

7-277 OMH

**JOB DESCRIPTION** Carpenter - Building / Heavy&Highway

**DISTRICT 2**

**ENTIRE COUNTIES**

Albany, Allegany, Broome, Cattaraugus, Cayuga, Chautauqua, Chemung, Chenango, Clinton, Columbia, Cortland, Delaware, Erie, Essex, Franklin, Fulton, Genesee, Greene, Hamilton, Herkimer, Jefferson, Lewis, Livingston, Madison, Monroe, Montgomery, Niagara, Oneida, Onondaga, Ontario, Orleans, Oswego, Otsego, Rensselaer, Saratoga, Schenectady, Schoharie, Schuyler, Seneca, St. Lawrence, Steuben, Sullivan, Tioga, Tompkins, Ulster, Warren, Washington, Wayne, Wyoming, Yates

**PARTIAL COUNTIES**

Orange: The area lying on Northern side of Orange County demarcated by a line drawn from the Bear Mountain Bridge continuing west to the Bear Mountain Circle, continue North on 9W to the town of Cornwall where County Road 107 (also known as Quaker Rd) crosses under 9W, then east on County Road 107 to Route 32, then north on Route 32 to Orrs Mills Rd, then west on Orrs Mills Rd to Route 94, continue west and south on Route 94 to the Town of Chester, to the intersection of Kings Highway, continue south on Kings Highway to Bellvale Rd, west on Bellvale Rd to Bellvale Lakes Rd, then south on Bellvale Lakes Rd to Kain Rd, southeast on Kain Rd to Route 17A, then north and southeast along Route 17A to Route 210, then follow Route 210 to NJ Border.

**WAGES**

Wages per hour:	07/01/2023	07/01/2024
		Additional
Carpenter - ONLY for Artificial Turf/Synthetic Sport Surface	\$ 34.48	\$ 2.25*

\*To be allocated at a later date

Note - Does not include the operation of equipment. Please see Operating Engineers rates.

**SUPPLEMENTAL BENEFITS**

Per hour:

Journeyman \$ 26.30

**OVERTIME PAY**

See (B, E, Q, X) on OVERTIME PAGE

**HOLIDAY**

Paid: See (5) on HOLIDAY PAGE  
 Overtime: See (5, 6, 16) on HOLIDAY PAGE

Notes:

When a holiday falls upon a Saturday, it shall be observed on the preceding Friday. When a holiday falls upon a Sunday, it shall be observed on the following Monday.

An employee taking an unexcused day off the regularly scheduled day before or after a paid Holiday shall not receive Holiday pay.

**REGISTERED APPRENTICES**

Wages per hour (1300 hour terms at the following percentage of Journeyman's wage):

1st	2nd	3rd	4th
65%	70%	75%	80%

Supplemental Benefits per hour:

1st term	\$ 17.56
2nd term	18.04
3rd term	20.06
4th term	20.54

2-42AtSS

**Carpenter - Heavy&Highway**

**06/01/2024**

**JOB DESCRIPTION** Carpenter - Heavy&Highway

**DISTRICT 2**

**ENTIRE COUNTIES**

Chenango, Herkimer, Madison, Oneida, Otsego

**WAGES**

Per hour	07/01/2023	07/01/2024
		Additional
Carpenter	\$ 38.28	\$ 4.25*
Piledriver	38.28	4.25*
Diver-Wet Day	63.28	4.25*
Diver-Dry Day	39.28	4.25*
Diver-Tender	39.28	4.25*

\*To be allocated at a later date.

NOTE ADDITIONAL AMOUNTS PAID FOR THE FOLLOWING WORK LISTED BELOW (per hour worked):

- When project owner mandates a single irregular work shift, the employee will receive an additional \$3.00 per hour. A single irregular work shift can start any time from 5:00 p.m. to 1:00 a.m.
- State or Federal designated hazardous site, requiring protective gear shall be an additional \$2.50 per hour.
- Certified welders when required to perform welding work will receive an additional \$2.50 per hour.

**ADDITIONAL NOTES PERTAINING TO DIVERS/TENDERS:**

- Divers and Tenders shall receive one and one half (1 1/2) times their regular diver and tender rate of pay for Effluent and Slurry diving.
- Divers and tenders being paid at the specified rate for Effluent and Slurry diving shall have all overtime rates based on the specified rate plus the appropriate overtime rates (one and one half or two times the specified rate for Slurry and Effluent divers and tenders).
- The pilot of an ADS or submersible will receive one and one-half (1 1/2) times the Diver-Wet Day Rate for time submerged.
- All crew members aboard a submersible shall receive the Diver-Wet Day rate.
- Depth pay for Divers based upon deepest depth on the day of the dive (per diem payment):
  - 0' to 50' no additional fee
  - 51'to 100' additional \$.50 per foot
  - 101'to 150' additional \$0.75 per foot
  - 151'and deeper additional \$1.25 per foot
- Penetration pay for Divers based upon deepest penetration on the day of the dive (per diem payment):
  - 0' to 50' no additional fee
  - 51' to 100' additional \$.75 per foot
  - 101' and deeper additional \$1.00 per foot
- Diver rates applies to all hours worked on dive day.

NOTE - The 'Employer Registration' (30.1) use of a '4 Day/10 Hour Work schedules' will no longer be accepted or processed. All registered projects prior to June 30,2023 will expire within the granted time frame.

For Pre-Registered Projects Four (4), Ten (10) hour days may be worked at straight time during a week, Monday thru Thursday. Friday may be used as a make-up day. Tuesday thru Friday may be worked with no make-up day. For further clarification contact your local Bureau Office.

**SUPPLEMENTAL BENEFITS**

Per hour:

Journeyman \$ 26.30

**OVERTIME PAY**

See (B, E, Q) on OVERTIME PAGE

**HOLIDAY**

Paid: See (5, 6) on HOLIDAY PAGE

Overtime: See (5, 6) on HOLIDAY PAGE

- In the event a Holiday falls on a Saturday, the Friday before will be observed as a Holiday. If a Holiday falls on a Sunday, then Monday will be observed as a Holiday. Employee must work scheduled work day before and after the Holiday.

- The employee must work their scheduled workday before and their scheduled workday after the holiday to receive holiday pay.

**REGISTERED APPRENTICES**

**CAPRENTER APPRENTICES**

Wages per hour (1040 hour terms at the following percentage of journeyman's base wage):

1st	2nd	3rd	4th	5th
65%	70%	75%	80%	85%

Supplemental Benefits per hour:

\$ 17.56	\$ 18.04	\$ 20.01	\$ 20.49	\$ 20.97
----------	----------	----------	----------	----------

**PILEDRIIVER/DOCKBUILDER APPRENTICES**

Wages per hour (1300 hour terms at the following percentage of journeyman's base wage):

1st	2nd	3rd	4th
65%	70%	80%	85%

Supplemental Benefits per hour:

\$ 17.56	\$ 18.04	\$ 20.49	\$ 20.97
----------	----------	----------	----------

**NOTE ADDITIONAL AMOUNTS PAID PER HOUR WORKED TO APPRENTICES FOR SPECIFIC TYPES OF WORK PERFORMED:**

- When project owner mandates a single irregular work shift, the employee will receive an additional \$3.00 per hour. A single irregular work shift can start any time from 5:00 p.m. to 1:00 a.m.
- State or Federal designated hazardous site, requiring protective gear shall be an additional \$2.50 per hour.
- Certified welders when required to perform welding work will receive an additional \$2.50 per hour.

2-277HH-CHMOO

**Electrician**

**06/01/2024**

**JOB DESCRIPTION** Electrician

**DISTRICT** 6

**ENTIRE COUNTIES**

Cortland, Herkimer, Madison, Oneida, Oswego

**PARTIAL COUNTIES**

Cayuga: Townships of Ira, Locke, Sempronius, Sterling, Summerhill and Victory.

Chenango: Only the Townships of Columbus, New Berlin and Sherburne.

Onondaga: Entire County except Townships of Elbridge and Skaneateles.

Otsego: Only the Townships of Plainfield, Richfield, Springfield, Cherry Valley, Roseboom, Middlefield, Otsego, Exeter, Edmeston,

Burlington, Pittsfield and New Lisbon.

Tompkins: Only the Township of Groton.

Wayne: Only the Townships of Huron, Wolcott, Rose and Butler.

**WAGES**

Per hour: 07/01/2023

Electrician	\$ 44.00
Teledata	44.00
Cable Splicer	48.40

NOTE: Additional premiums for the following work listed:

- Additional \$2.00 per hour for work performed over 35 feet above the ground, floor, or roof levels or where work is required in tunnels, shafts, or under compressed air 35 feet below the ground level.

- Additional \$2.50 per hour for working over 50 feet above or below ground, floor, or roof level. This includes work on ladders, "toothpicks", scaffolds, boatswain chairs, towers, smokestacks or other open structures, or mechanical lifts used over 60 feet.

SHIFT WORK: THE FOLLOWING RATES WILL APPLY ON ALL CONTRACTING AGENCY MANDATED MULTIPLE SHIFTS OF EIGHT (8) HOURS FOR AT LEAST FIVE (5) DAYS DURATION WHICH MAY HAVE BEEN WORKED. WHEN TWO (2) SHIFTS OR THREE (3) SHIFTS ARE WORKED:

1ST SHIFT	8:00AM - 4:30PM:	Regular wage rate
2ND SHIFT	4:30 PM - 1:00 AM:	Regular wage rate plus 15%
3RD SHIFT	12:30 AM - 9:00 AM:	Regular wage rate plus 25%

Occupied Conditions: When necessary to perform alteration and/or renovation work and owner mandates (due to occupied conditions) prevent the work from being performed during "normal" working hours (defined as between 6:00 a.m. and 4:30 p.m. Monday through Friday), alternate hours may be worked, provided: 1) The hours are established for a minimum of five (5) days duration or the length of the job, whichever is shorter; and 2) An entire work scope within a job-site area is performed utilizing the varied hours. If these conditions are satisfied, all hours worked Monday through Friday of a shift that starts before or ends after the "normal" hours, shall be paid at the appropriate rate plus fifteen percent (15%). However, the following restrictions shall apply:

- 1) "Alternate" hours shall consist of a minimum of eight consecutive hours per day
- 2) Hours worked in excess of eight (8) hours per day, Monday through Friday, shall be paid at a rate of one and one-half times the applicable rate (day-shift + 15%)
- 3) Hours worked on Saturday shall be paid at time and one-half the applicable rate.
- 4) Hours worked on Sundays and Holidays shall be paid at double the straight time rate.
- 5) Work of a new construction nature may not be worked under these conditions.

NOTE - The "Employer Registration" (30.1) use of a '4 Day/10 Hour Work schedules' will no longer be accepted or processed. All registered projects prior to June 30, 2023 will expire within the granted time frame.

For Pre-Registered Projects Four (4), Ten (10) hour days may be worked at straight time during a week, Monday thru Thursday. Friday may be used as a make-up day. Tuesday thru Friday may be worked with no make-up day. For further clarification contact your local Bureau Office.

**SUPPLEMENTAL BENEFITS**

Per hour:	\$ 30.17 plus
Journeyman	3% of hourly wage paid*

\*NOTE: The 3% is based on the hourly wage paid, straight time or premium rate.

**OVERTIME PAY**

See (B, \*E, Q) on OVERTIME PAGE

\* NOTE: On Saturday the first 10 hours worked shall be paid at a rate of one and one-half times the applicable rate. All additional hours are payable at double the straight time rate.

NOTE: WAGE CAP - Double the straight time hourly base wage shall be the maximum hourly wage compensation for any hour worked. Contractor is still responsible to pay the hourly benefit amount for each hour worked.

**HOLIDAY**

Paid:	See (1) on HOLIDAY PAGE
Overtime:	See (5, 6) on HOLIDAY PAGE

NOTE: If any of the above holidays fall on Saturday, Friday shall be observed as the holiday. If any of the above holidays fall on Sunday, Monday shall be observed as the holiday.

**REGISTERED APPRENTICES**

WAGES per hour: Hourly terms at the following percentage of Journeyman's wage.

1st period 40% (0-1000 hrs.)	\$ 17.60
2nd period 45% (1001-2000)	19.80
3rd period 50% (2001-3500)	22.00
4th period 60% (3501-5000)	26.40
5th period 70% (5001-6500)	30.80
6th Period 80% (6501-8000)	35.20

SUPPLEMENTAL BENEFITS per hour:

1st period	\$ 13.59*
2nd period	\$ 13.59*
3rd period	\$ 27.42*
4th period	\$ 27.97*
5th period	\$ 28.52*
6th period	\$ 29.07*

\* PLUS 3% OF HOURLY WAGE PAID, STRAIGHT TIME RATE OR PREMIUM RATE.

6-43

**Elevator Constructor**

**06/01/2024**

**JOB DESCRIPTION** Elevator Constructor

**DISTRICT 6**

**ENTIRE COUNTIES**

Broome, Cayuga, Chenango, Cortland, Franklin, Jefferson, Lewis, Onondaga, Oswego, St. Lawrence, Tioga, Tompkins

**PARTIAL COUNTIES**

Delaware: Only the towns of: Tompkins, Walton, Masonville, Sidney, Franklin and Deposit.

Madison: Only the towns of: Cazenovia, DeRuyter, Eaton, Fenner, Georgetown, Lebanon, Lenox, Nelson and Sullivan.

Oneida: Only the towns of: Camden, Florence and Vienna.

**WAGES**

Per hour:	07/01/2023	01/01/2024	01/01/2025	01/01/2026
Elevator Constructor	\$ 53.69	\$ 56.02	\$ 58.455	\$ 61.003
Helper	37.58	39.21	40.92	42.70

NOTE - The "Employer Registration" (30.1) use of a '4 Day/10 Hour Work schedules' will no longer be accepted or processed. All registered projects prior to June 30, 2023 will expire within the granted time frame.

For Pre-Registered Projects Four (4), Ten (10) hour days may be worked at straight time during a week, Monday thru Thursday. Friday may be used as a make-up day. Tuesday thru Friday may be worked with no make-up day. For further clarification contact your local Bureau Office.

**SUPPLEMENTAL BENEFITS**

Per hour:

Journeyman	\$ 37.335*	\$ 37.885*	\$ 38.435*	\$ 38.985*
------------	------------	------------	------------	------------

\*NOTE - add 6% of regular hourly rate for all hours worked. Add 8% of regular hourly rate if more than 5 years of service.

**OVERTIME PAY**

See (D, O) on OVERTIME PAGE

**HOLIDAY**

Paid: See (5, 6, 15, 16) on HOLIDAY PAGE

Overtime: See (5, 6, 15, 16) on HOLIDAY PAGE

NOTE: When a paid holiday falls on a Saturday, it shall be observed on Friday. When a paid holiday falls on Sunday, it shall be observed on Monday.

**REGISTERED APPRENTICES**

WAGES per hour: 1 year terms at the following percentage of the Elevator Constructor wage.

0-6 months	6-12 months	2nd year	3rd year	4th year
50%	55%	65%	70%	80%

SUPPLEMENTAL BENEFITS per hour:

0-6 months: 6% of the hourly apprentice rate paid, no additional supplemental benefits.

All other terms: Same as Journeyman.

6-62.1

**Elevator Constructor** **06/01/2024**

**JOB DESCRIPTION** Elevator Constructor

**DISTRICT 1**

**ENTIRE COUNTIES**

Albany, Clinton, Essex, Fulton, Hamilton, Herkimer, Montgomery, Otsego, Rensselaer, Saratoga, Schenectady, Schoharie, Warren, Washington

**PARTIAL COUNTIES**

Madison: Madison Only the towns of: Brookfield, Hamilton, Lincoln, Madison, Smithfield, Stockbridge and the City of Oneida  
 Oneida: Entire county except the towns of: Camden, Florence, and Vienna.

**WAGES**

Per hour	07/01/2023	01/01/2024
Mechanic	\$ 53.02	\$ 55.32
Helper	70% of Mechanic Wage Rate	70% of Mechanic Wage Rate

NOTE - The "Employer Registration" (30.1) use of a '4 Day/10 Hour Work schedules' will no longer be accepted or processed. All registered projects prior to June 30, 2023 will expire within the granted time frame.

For Pre-Registered Projects Four (4), Ten (10) hour days may be worked at straight time during a week, Monday thru Thursday. Friday may be used as a make-up day. Tuesday thru Friday may be worked with no make-up day. For further clarification contact your local Bureau Office.

**SUPPLEMENTAL BENEFITS**

Per hour	07/01/2023	01/01/2024
Journeyman/Helper	\$ 37.335*	\$ 37.885*

(\*)Plus 6% of hourly rate, if less than 5 years of service. Plus 8% of hourly rate, if more than 5 years of service.

**OVERTIME PAY**

See (D, O) on OVERTIME PAGE

**HOLIDAY**

Paid: See (5, 6, 15, 16) on HOLIDAY PAGE  
 Overtime: See (5, 6, 15, 16) on HOLIDAY PAGE

Note: When a paid holiday falls on Saturday, it shall be observed on Friday. When a paid holiday falls on Sunday, it shall be observed on Monday.

**REGISTERED APPRENTICES**

Wages per hour:

0-6 mo*	6-12 mo	2nd yr	3rd yr	4th yr
50%	55 %	65 %	70 %	80 %

(\*)Plus 6% of the hourly rate, no additional supplemental benefits.

Supplemental Benefits - per hour worked:

Same as Journeyman/Helper

1-35

**Glazier** **06/01/2024**

**JOB DESCRIPTION** Glazier

**DISTRICT 5**

**ENTIRE COUNTIES**

Cayuga, Cortland, Herkimer, Madison, Oneida, Onondaga, Oswego

**WAGES**

Per Hour: 07/01/2023

Glazier \$ 26.80

\*\* NOTE-The "Employer Registration" (30.1) use of a '4 Day/10 Hour Work schedules' will no longer be accepted or processed. All registered projects prior to JUNE 30, 2023 will expire within the granted time frame.

For Pre-Registered Projects Four(4),Ten(10)hour days may be worked at straight time during a week Monday thru Thursday. Friday may be used as a make-up day. Tuesday thru Friday may be worked with no make-up day. For further clarification contact your local Bureau Office

**SUPPLEMENTAL BENEFITS**

Per hour:

Journeyman \$ 25.39

**OVERTIME PAY**

See (B,E,E2\*,Q) on OVERTIME PAGE.

\*Note - Or circumstances beyond the control of the employer.

**HOLIDAY**

Paid: See (1) on HOLIDAY PAGE  
 Overtime: See (5, 6) on HOLIDAY PAGE

**REGISTERED APPRENTICES**

1000 hour terms:

Appr. 1st term	\$17.50
Appr. 2nd term	18.50
Appr. 3rd term	19.50
Appr. 4th term	20.50
Appr. 5th term	21.50
Appr. 6th term	22.50
Appr. 7th term	23.50
Appr. 8th term	24.50

Supplemental Benefits per hour:

Appr. 1st term	\$ 12.58
Appr. 2nd term	12.58
Appr. 3rd term	18.58
Appr. 4th term	18.58
Appr. 5th term	19.58
Appr. 6th term	19.58
Appr. 7th term	20.58
Appr. 8th term	20.58

5-677.Z-2

**Insulator - Heat & Frost**

**06/01/2024**

**JOB DESCRIPTION** Insulator - Heat & Frost

**DISTRICT 7**

**ENTIRE COUNTIES**

Broome, Cayuga, Chemung, Chenango, Cortland, Herkimer, Jefferson, Lewis, Madison, Oneida, Onondaga, Oswego, Otsego, Schuyler, Seneca, St. Lawrence, Tioga, Tompkins

**WAGES**

Per hour: 07/01/2023

Asbestos Installer \$ 38.50  
 Insulation Installer 38.50  
 (On mechanical systems only)

NOTE: THE FOLLOWING RATES WILL APPLY ON ALL CONTRACTING AGENCY MANDATED SHIFTS WORKED.

1ST SHIFT	\$ 38.50
2ND SHIFT	44.27
3RD SHIFT	46.20



NOTE - The "Employer Registration" (30.1) use of a '4 Day/10 Hour Work schedules' will no longer be accepted or processed. All registered projects prior to June 30, 2023 will expire within the granted time frame.

For Pre-Registered Projects Four (4), Ten (10) hour days may be worked at straight time during a week, Monday thru Thursday. Friday may be used as a make-up day. Tuesday thru Friday may be worked with no make-up day. For further clarification contact your local Bureau Office.

**SUPPLEMENTAL BENEFITS**

Per hour:

Journeyman \$ 25.09

**OVERTIME PAY**

See (\*B1, \*\*K, P) on OVERTIME PAGE

\*NOTE: First 10 hours on Saturday.

\*\*NOTE: Holidays that fall on Sunday are subject to double time.

**HOLIDAY**

Paid: See (1) on HOLIDAY PAGE

Overtime: See (2\*,4,6,28) on HOLIDAY PAGE

\*Triple time for Labor Day if worked.

**REGISTERED APPRENTICES**

WAGES per hour: One year terms at the following percentage of Journeyman's wage.

1st	2nd	3rd	4th
60%	70%	80%	90%
\$ 23.10	\$ 26.95	\$ 30.80	\$ 34.65

SUPPLEMENTAL BENEFITS per hour:

\$ 22.59	\$ 22.59	\$ 25.09	\$ 25.09
----------	----------	----------	----------

7-30-Syracuse

**Ironworker**

**06/01/2024**

**JOB DESCRIPTION** Ironworker

**DISTRICT 7**

**ENTIRE COUNTIES**

Franklin, Herkimer, Lewis, Oneida, St. Lawrence

**PARTIAL COUNTIES**

Chenango: Only the Townships of Columbus, New Berlin, North Norwich, Plymouth, Sherburne and Smyrna.

Fulton: Only the Townships of Caroga, Ephratah, Oppenheim, Stratford.

Hamilton: Only the Townships of Arietta, Indian Lake, Inlet, Lake Pleasant, Long Lake and Morehouse.

Jefferson: Only the Townships of Antwerp, Champion, Philadelphia and Wilna.

Madison: Only the Townships of Brookfield, Eaton, Hamilton, Lebanon, Madison, Oneida and Stockbridge.

Montgomery: Only the Townships of Canajoharie, Minden, Palatine and St. Johnsville.

Otsego: Only the Townships of Burlington, Cherry Valley, Decatur, Edmeston, Exeter, Hartwick, Middlefield, New Lisbon, Otsego, Pittsfield, Plainfield, Richfield, Roseboom, Springfield and Westford, and Village of Cooperstown.

**WAGES**

Per hour: 07/01/2023

Structural/Reinforcing	\$ 32.00
Mach. Mover/Ornamental	32.00
Stone Derrickman	32.00
Chain Link Fence	32.00
Sheeter Ironworker	32.00
Pre-Engineered Building	32.00
Window Erector	32.00
Precast Erector	32.00
Welder	32.00

**SUPPLEMENTAL BENEFITS**

Per hour:

Journeyman \$ 31.25

**OVERTIME PAY**

See (B, E, Q) on OVERTIME PAGE

**HOLIDAY**

Paid: See (1) on HOLIDAY PAGE

Overtime: See (5, 6) on HOLIDAY PAGE  
 NOTE: Any holiday which occurs on Sunday shall be observed the following Monday.

**REGISTERED APPRENTICES**

WAGES per hour: 1500 hour terms at the following wage.

1-1500hrs	\$ 19.50
1501-3000hrs	21.50
3001-4500hrs	23.50
4501-6000hrs	25.50

SUPPLEMENTAL BENEFITS per hour:

1-1500hrs	\$ 13.03
1501-3000hrs	21.30
3001-4500hrs	22.48
4501-6000hrs	23.66

7-440

**Laborer - Building**

**06/01/2024**

**JOB DESCRIPTION** Laborer - Building

**DISTRICT 1**

**ENTIRE COUNTIES**  
 Hamilton, Herkimer, Madison, Oneida

**PARTIAL COUNTIES**  
 Fulton: Only the Townships of Stratford, Oppenheim, Caroga and Ephratah  
 Montgomery: Only the Townships of Minden, St. Johnsville, Canajoharie, Palatine and Root

**WAGES**

- GROUP #1: Basic
- GROUP #2: Pipe Layer, Mortar Mixer, Walk behind Mortar Buggie and Power Lift
- GROUP #3: Wagon Drill(Where separate air compressor unit supplies power.)
- GROUP #4: Blaster, Formsetter, Riding Mortar Buggy
- GROUP #5: Hazardous Waste Removal
- GROUP #6: Asbestos and Lead Removal

WAGES per hour:	07/01/2023	07/01/2024
Building Laborer:		Additional
Group # 1	\$ 30.10	+ \$4.75*
Group # 2	30.25	+ \$4.75*
Group # 3	30.50	+ \$4.75*
Group # 4	30.60	+ \$4.75*
Group # 5	31.60	+ \$4.75*
Group # 6	31.60	+ \$4.75*

(\*) To be allocated at later date.

**SUPPLEMENTAL BENEFITS**

Per hour:

	07/01/2023
All groups	\$ 25.09

**OVERTIME PAY**

See (B, E, E2, Q) on OVERTIME PAGE

**HOLIDAY**

Paid: See (1) on HOLIDAY PAGE  
 Overtime: See (5, 6) on HOLIDAY PAGE

**REGISTERED APPRENTICES**

Wages per hour  
 1000 Hour terms at the following percentage of Journeyperson's basic hourly wage.

1st	2nd	3rd	4th
65 %	70 %	80 %	80 %

Supplemental Benefits per hour worked

	07/01/2023
Apprentices	\$ 25.09

1-190z2B

**Laborer - Heavy&Highway** **06/01/2024**

**JOB DESCRIPTION** Laborer - Heavy&Highway

**DISTRICT 1**

**ENTIRE COUNTIES**

Hamilton, Herkimer, Madison, Oneida

**PARTIAL COUNTIES**

Fulton: Only Townships of Stratford, Oppenheim, Caroga and Ephratah  
 Montgomery: Only Townships of Minden, St. Johnsville, Canajoharie, Palatine and Root.

**WAGES**

GROUP # A: Basic, Drill Helper, Flagman, Outboard and Hand Boats.

GROUP # B: Bull Float, Chain Saw, Concrete Aggregate Bin, Concrete Bootmen, Gin Buggy, Hand or Machine Vibrator, Jack Hammer, Mason Tender, Mortar Mixer, Pavement Breaker, Handlers of all SteelMash, Small Generators for Laborers Tools, Installation of Bridge Drainage Pipe, Pipe Layers, Vibrator Type Rollers, Tamper, Drill Doctor, Tail or Screw Operator on Asphalt Paver, Water Pump Operators(1-1/2" and Single Diaphragm), Nozzle (Asphalt, Gunite, Seeding, and Sand Blasting), Laborers on Chain Link Fence Erection, Rock Splitter and Power Unit, Pusher Type Concrete Saw and all other Gas, Electric, Oil and Air Tool Operators, Wrecking Laborer.

GROUP # C: Rock or Drilling Machine Operators (only where a separate air compressor unit supplies power), Acetylene Torch Operators, Asphalt Raker and Powderman.

GROUP # D: Blasters, Form Setters (prefab curb radius), Stone or Granite Curb Setters.

GROUP # E: Employees performing hazardous waste removal, lead abatement and removal, or asbestos abatement and removal on a State and/or Federally designated waste site & where relevant State or Federal regulations require employees to use or wear forms of personal protection.

Per hour:	07/01/2023	07/01/2024
		Additional
Heavy/Highway Laborer:		
GROUP # A	\$ 37.65	+ \$3.25*
GROUP # B	37.85	+ \$3.25*
GROUP # C	38.05	+ \$3.25*
GROUP # D	38.25	+ \$3.25*
GROUP # E	40.15	+ \$3.25*

(\*) To be allocated at later date.

All employees who work a single irregular workday that starts from 5:00 pm to 1:00 am on a governmental mandated night shift shall be paid an additional \$5.00 per hour.

NOTE - The "Employer Registration" (30.1) use of a '4 Day/10 Hour Work schedules' will no longer be accepted or processed. All registered projects prior to June 30, 2023 will expire within the granted time frame.

For Pre-Registered Projects Four (4), Ten (10) hour days may be worked at straight time during a week, Monday thru Thursday. Friday may be used as a make-up day. Tuesday thru Friday may be worked with no make-up day. For further clarification contact your local Bureau Office.

**SUPPLEMENTAL BENEFITS**

Per hour: \$ 28.44

**OVERTIME PAY**

See (B, E, Q) on OVERTIME PAGE

**HOLIDAY**

Paid: See (5, 6) on HOLIDAY PAGE

Overtime: See (5, 6) on HOLIDAY PAGE

Note: If the holiday falls on Sunday, it will be celebrated on Monday. If the Monday Holiday is worked it will be paid at double time plus the Holiday pay. If the Holiday falls on a Saturday employer can choose to celebrate Saturday or give Friday off with pay. If the Saturday Holiday is worked it will be paid at double time plus the Holiday pay

**REGISTERED APPRENTICES**

Wages per hour

1000 hour terms at the following percentage of Journeyman's wage

1st	2nd	3rd	4th
65%	70%	80%	80%

SUPPLEMENTAL BENEFITS per hour worked

Apprentices \$ 28.44

1-190z2H/H

**Laborer - Tunnel**

**06/01/2024**

**JOB DESCRIPTION** Laborer - Tunnel

**DISTRICT 1**

**ENTIRE COUNTIES**

Albany, Fulton, Hamilton, Herkimer, Madison, Montgomery, Oneida, Rensselaer, Saratoga, Schenectady, Schoharie, Washington

**WAGES**

Class 1: All support laborers/sandhogs working above the shaft or tunnel

Class 2: All laborers/sandhogs working in the shaft or tunnel

Class 4: Safety Miners

Class 5: Site work related to Shaft/Tunnel

Per Hour

07/01/2023

Class 1	\$ 45.65
Class 2	47.65
Class 4	49.90
Class 5	41.15

Toxic and hazardous waste, lead abatement and asbestos abatement work will be paid an additional \$ 3.00 an hour.

All Government mandated irregular shift work Monday through Saturday is subject to Premium rate. All Government mandated irregular shift work that falls on Sunday is subject to double Premium rate.

**SUPPLEMENTAL BENEFITS**

Per hour

Journeyman	\$ 26.91
	+1.59*

\*This portion of the benefit is NOT subject to the SAME PREMIUM as shown for overtime

**OVERTIME PAY**

See (B, E, Q, V, X) on OVERTIME PAGE

**HOLIDAY**

Paid: See (5, 6, 15, 25) on HOLIDAY PAGE

Overtime: See (5, 6, 15, 16, 25) on HOLIDAY PAGE

Note: When a holiday falls on Sunday, the following Monday shall be considered a holiday and all work performed on either day shall be at the double time rate. When a holiday falls on Saturday, the preceding Friday shall be considered a holiday and all work performed on either day shall be at the double time rate.

**REGISTERED APPRENTICES**

FOR APPRENTICE RATES, refer to the appropriate Laborer Heavy & Highway wage rate contained in the wage schedule for the County and Location where the work is to be performed.

1-190/157T

**Lineman Electrician**

**06/01/2024**

**JOB DESCRIPTION** Lineman Electrician

**DISTRICT 6**

**ENTIRE COUNTIES**

Albany, Allegany, Broome, Cattaraugus, Cayuga, Chautauqua, Chemung, Chenango, Clinton, Columbia, Cortland, Delaware, Dutchess, Erie, Essex, Franklin, Fulton, Genesee, Greene, Hamilton, Herkimer, Jefferson, Lewis, Livingston, Madison, Monroe, Montgomery, Niagara, Oneida, Onondaga, Ontario, Orange, Orleans, Oswego, Otsego, Putnam, Rensselaer, Rockland, Saratoga, Schenectady, Schoharie, Schuyler, Seneca, St. Lawrence, Steuben, Sullivan, Tioga, Tompkins, Ulster, Warren, Washington, Wayne, Wyoming, Yates

**WAGES**

A Lineman/Technician shall perform all overhead aerial work. A Lineman/Technician on the ground will install all electrical panels, connect all grounds, install and connect all electrical conductors, assembly of all electrical materials, conduit, pipe, or raceway; placing of fish wire; pulling of cables, wires or fiber optic cable through such raceways; splicing of conductors; dismantling of such structures, lines or equipment.

A Groundman/Truck Driver shall: Build and set concrete forms, handle steel mesh, set footer cages, transport concrete in a wheelbarrow, hand or machine concrete vibrator, finish concrete footers, mix mortar, grout pole bases, cover and maintain footers while curing in cold weather, operate jack hammer, operate hand pavement breaker, tamper, concrete and other motorized saws, as a drill helper, operate and maintain generators, water pumps, chainsaws, sand blasting, operate mulching and seeding machine, air tools, electric tools, gas tools, load and unload materials, hand shovel and/or broom, prepare and pour mastic and other fillers, assist digger operator/equipment operator in ground excavation and restoration, landscape work and painting. Only when assisting a lineman technician, a groundman/truck driver may assist in installing conduit, pipe, cables and equipment.

NOTE: Includes Teledata Work within ten (10) feet of High Voltage Transmission Lines. Also includes digging of holes for poles, anchors, footer, and foundations for electrical equipment.

Below rates applicable on all overhead and underground distribution and maintenance work, and all overhead and underground transmission line work and the installation of fiber optic cable where no other construction trades are or have been involved. (Ref #14.01.01)

Per hour:	07/01/2023	05/06/2024
Group A:		
Lineman, Technician	\$ 57.40	\$ 58.90
Crane, Crawler Backhoe	57.40	58.90
Welder, Cable Splicer	57.40	58.90
Group B:		
Digging Mach. Operator	51.66	53.01
Tractor Trailer Driver	48.79	50.07
Groundman, Truck Driver	45.92	47.12
Equipment Mechanic	45.92	47.12
Flagman	34.44	35.34

Additional \$1.00 per hour for entire crew when a helicopter is used.

Below rates applicable on all electrical sub-stations, switching structures, fiber optic cable and all other work not defined as "Utility outside electrical work". (Ref #14.02.01-A)

Group A:		
Lineman, Technician	\$ 57.40	\$ 58.90
Crane, Crawler Backhoe	57.40	58.90
Cable Splicer	63.14	64.79
Certified Welder, Pipe Type Cable	60.27	61.85
Group B:		
Digging Mach. Operator	51.66	53.01
Tractor Trailer Driver	48.79	50.07
Groundman, Truck Driver	45.92	47.12
Equipment Mechanic	45.92	47.12
Flagman	34.44	35.34

Additional \$1.00 per hour for entire crew when a helicopter is used.

Below rates apply on switching structures, maintenance projects, railroad catenary install/maintenance third rail installation, bonding of rails and pipe type cable and installation of fiber optic cable. (Ref #14.02.01-B)

Group A:		
Lineman, Tech, Welder	\$ 58.72	\$ 60.22
Crane, Crawler Backhoe	58.72	60.22
Cable Splicer	64.59	66.24
Certified Welder, Pipe Type Cable	61.66	63.23
Group B:		
Digging Mach. Operator	52.85	54.20
Tractor Trailer Driver	49.91	51.19
Groundman, Truck Driver	46.98	48.18
Equipment Mechanic	46.98	48.18
Flagman	35.23	36.13

Additional \$1.00 per hour for entire crew when a helicopter is used.

Below rates applicable on all overhead and underground transmission line work & fiber optic cable where other construction trades are or have been involved. This applies to transmission line work only, not other construction. (Ref #14.03.01)

Group A:		
Lineman, Tech, Welder	\$ 59.91	\$ 61.41
Crane, Crawler Backhoe	59.91	61.41
Cable Splicer	59.91	61.41
Group B:		
Digging Mach. Operator	53.92	55.27
Tractor Trailer Driver	50.92	52.20
Groundman, Truck Driver	47.93	49.13
Equipment Mechanic	47.93	49.13
Flagman	35.95	36.85

Additional \$1.00 per hour for entire crew when a helicopter is used.

NOTE: THE FOLLOWING RATES WILL APPLY ON ALL CONTRACTING AGENCY MANDATED MULTIPLE SHIFTS OF AT LEAST FIVE (5) DAYS DURATION WORKED BETWEEN THE HOURS LISTED BELOW:

1ST SHIFT	8:00 AM to 4:30 PM REGULAR RATE
2ND SHIFT	4:30 PM to 1:00 AM REGULAR RATE PLUS 17.3 %
3RD SHIFT	12:30 AM to 9:00 AM REGULAR RATE PLUS 31.4 %

NOTE - The "Employer Registration" (30.1) use of a '4 Day/10 Hour Work schedules' will no longer be accepted or processed. All registered projects prior to June 30, 2023 will expire within the granted time frame.

For Pre-Registered Projects Four (4), Ten (10) hour days may be worked at straight time during a week, Monday thru Thursday. Friday may be used as a make-up day. Tuesday thru Friday may be worked with no make-up day. For further clarification contact your local Bureau Office.

**SUPPLEMENTAL BENEFITS**

Per hour:

	07/01/2023	05/06/2024
Group A	\$ 29.40 *plus 7% of the hourly wage paid	\$ 30.90 *plus 7% of the hourly wage paid
Group B	\$ 26.40 *plus 7% of the hourly wage paid	\$ 26.90 *plus 7% of the hourly wage paid

\*The 7% is based on the hourly wage paid, straight time or premium time.

**OVERTIME PAY**

See (B, E, Q, X) on OVERTIME PAGE. \*Note\* Double time for all emergency work designated by the Dept. of Jurisdiction.

NOTE: WAGE CAP - Double the straight time hourly base wage shall be the maximum hourly wage compensation for any hour worked. Contractor is still responsible to pay the hourly benefit amount for each hour worked.

**HOLIDAY**

Paid See ( 5, 6, 8, 13, 25 ) on HOLIDAY PAGE plus Governor of NYS Election Day.  
 Overtime See ( 5, 6, 8, 13, 25 ) on HOLIDAY PAGE plus Governor of NYS Election Day.

NOTE: All paid holidays falling on Saturday shall be observed on the preceding Friday. All paid holidays falling on Sunday shall be observed on the following Monday. Supplements for holidays paid at straight time.

**REGISTERED APPRENTICES**

WAGES per hour: 1000 hour terms at the following percentage of the applicable Journeyman Lineman wage.

1st	2nd	3rd	4th	5th	6th	7th
60%	65%	70%	75%	80%	85%	90%

SUPPLEMENTAL BENEFITS per hour:

07/01/2023	05/06/2024
------------	------------

\$ 26.40 *plus 7% of the hourly wage paid	\$ 26.90 *plus 7% of the hourly wage paid
----------------------------------------------------	----------------------------------------------------

\*The 7% is based on the hourly wage paid, straight time or premium time.

6-1249a

---

**Lineman Electrician - Teledata** **06/01/2024**

---

**JOB DESCRIPTION** Lineman Electrician - Teledata **DISTRICT 6**

**ENTIRE COUNTIES**  
 Albany, Allegany, Broome, Cattaraugus, Cayuga, Chautauqua, Chemung, Chenango, Clinton, Columbia, Cortland, Delaware, Dutchess, Erie, Essex, Franklin, Fulton, Genesee, Greene, Hamilton, Herkimer, Jefferson, Lewis, Livingston, Madison, Monroe, Montgomery, Niagara, Oneida, Onondaga, Ontario, Orange, Orleans, Oswego, Otsego, Putnam, Rensselaer, Rockland, Saratoga, Schenectady, Schoharie, Schuyler, Seneca, St. Lawrence, Steuben, Sullivan, Tioga, Tompkins, Ulster, Warren, Washington, Wayne, Westchester, Wyoming, Yates

**WAGES**  
 Per hour:

For outside work, stopping at first point of attachment (demarcation).

	07/01/2023	01/01/2024	01/01/2025
Cable Splicer	\$ 37.73	\$ 39.24	\$ 40.81
Installer, Repairman	\$ 35.81	\$ 37.24	\$ 38.73
Teledata Lineman	\$ 35.81	\$ 37.24	\$ 38.73
Tech., Equip. Operator	\$ 35.81	\$ 37.24	\$ 38.73
Groundman	\$ 18.98	\$ 19.74	\$ 20.53

NOTE: EXCLUDES Teledata work within ten (10) feet of High Voltage (600 volts and over) transmission lines. For this work please see LINEMAN.

NOTE: THE FOLLOWING RATES WILL APPLY ON ALL CONTRACTING AGENCY MANDATED MULTIPLE SHIFTS OF AT LEAST FIVE (5) DAYS DURATION WORKED:

1ST SHIFT	REGULAR RATE
2ND SHIFT	REGULAR RATE PLUS 10%
3RD SHIFT	REGULAR RATE PLUS 15%

**SUPPLEMENTAL BENEFITS**

Per hour:	07/01/2023	01/01/2024	01/01/2025
Journeyman	\$ 5.70 *plus 3% of the hourly wage paid	\$ 5.70 *plus 3% of the hourly wage paid	\$ 5.70 *plus 3% of the hourly wage paid

\*The 3% is based on the hourly wage paid, straight time rate or premium rate.

**OVERTIME PAY**

See (B, E, Q) on OVERTIME PAGE

NOTE: WAGE CAP - Double the straight time hourly base wage shall be the maximum hourly wage compensation for any hour worked. Contractor is still responsible to pay the hourly benefit amount for each hour worked.

**HOLIDAY**

Paid: See (1) on HOLIDAY PAGE  
 Overtime: See (5, 6, 16) on HOLIDAY PAGE

6-1249LT - Teledata

---

**Lineman Electrician - Traffic Signal, Lighting** **06/01/2024**

---

**JOB DESCRIPTION** Lineman Electrician - Traffic Signal, Lighting **DISTRICT 6**

**ENTIRE COUNTIES**  
 Albany, Allegany, Broome, Cattaraugus, Cayuga, Chautauqua, Chemung, Chenango, Clinton, Cortland, Delaware, Erie, Essex, Franklin, Fulton, Genesee, Greene, Hamilton, Herkimer, Jefferson, Lewis, Livingston, Madison, Monroe, Montgomery, Niagara, Oneida, Onondaga, Ontario, Orleans, Oswego, Otsego, Rensselaer, Saratoga, Schenectady, Schoharie, Schuyler, Seneca, St. Lawrence, Steuben, Sullivan, Tioga, Tompkins, Warren, Washington, Wayne, Wyoming, Yates

**WAGES**

Lineman/Technician shall perform all overhead aerial work. A Lineman/Technician on the ground will install all electrical panels, connect all grounds, install and connect all electrical conductors which includes, but is not limited to road loop wires; conduit and plastic or other type pipes that carry conductors, flex cables and connectors, and to oversee the encasement or burial of such conduits or pipes.

A Groundman/Truck Driver shall: Build and set concrete forms, handle steel mesh, set footer cages, transport concrete in a wheelbarrow, hand or machine concrete vibrator, finish concrete footers, mix mortar, grout pole bases, cover and maintain footers while curing in cold weather, operate jack hammer, operate hand pavement breaker, tamper, concrete and other motorized saws, as a drill helper, operate and maintain generators, water pumps, chainsaws, sand blasting, operate mulching and seeding machine, air tools, electric tools, gas tools, load and unload materials, hand shovel and/or broom, prepare and pour mastic and other fillers, assist digger operator/equipment operator in ground excavation and restoration, landscape work and painting. Only when assisting a lineman technician, a groundman/truck driver may assist in installing conduit, pipe, cables and equipment.

A flagger's duties shall consist of traffic control only.  
 (Ref #14.01.01)

Per hour:	07/01/2023	05/06/2024
<b>Group A:</b>		
Lineman, Technician	\$ 49.32	\$ 50.54
Crane, Crawler Backhoe	49.32	50.54
Certified Welder	51.79	53.07
<b>Group B:</b>		
Digging Machine	44.39	45.49
Tractor Trailer Driver	41.92	42.96
Groundman, Truck Driver	39.46	40.43
Equipment Mechanic	39.46	40.43
Flagman	29.59	30.32

Above rates are applicable for installation, testing, operation, maintenance and repair on all Traffic Control (Signal) and Illumination (Lighting) projects, Traffic Monitoring Systems, and Road Weather Information Systems. Includes digging of holes for poles, anchors, footer foundations for electrical equipment; assembly of all electrical materials or raceway; placing of fish wire; pulling of cables, wires or fiber optic cable through such raceways; splicing of conductors; dismantling of such structures, lines or equipment.

NOTE: THE FOLLOWING RATES WILL APPLY ON ALL CONTRACTING AGENCY MANDATED MULTIPLE SHIFTS OF AT LEAST FIVE (5) DAYS DURATION WORKED BETWEEN THE HOURS LISTED BELOW:

1ST SHIFT	8:00 AM TO 4:30 PM	REGULAR RATE
2ND SHIFT	4:30 PM TO 1:00 AM	REGULAR RATE PLUS 17.3%
3RD SHIFT	12:30 AM TO 9:00 AM	REGULAR RATE PLUS 31.4%

NOTE - The "Employer Registration" (30.1) use of a '4 Day/10 Hour Work schedules' will no longer be accepted or processed. All registered projects prior to June 30, 2023 will expire within the granted time frame.

For Pre-Registered Projects Four (4), Ten (10) hour days may be worked at straight time during a week, Monday thru Thursday. Friday may be used as a make-up day. Tuesday thru Friday may be worked with no make-up day. For further clarification contact your local Bureau Office.

**SUPPLEMENTAL BENEFITS**

Per hour worked (but also required on non-worked holidays):

	07/01/2023	05/06/2024
<b>Group A</b>	\$ 29.40	\$ 30.90
	*plus 7% of the hourly wage paid	*plus 7% of the hourly wage paid
<b>Group B</b>	\$ 26.40	\$ 26.90
	*plus 7% of the hourly wage paid	*plus 7% of the hourly wage paid

\*The 7% is based on the hourly wage paid, straight time or premium time.

**OVERTIME PAY**

See (B, E, Q) on OVERTIME PAGE. \*Note\* Double time for all emergency work designated by the Dept. of Jurisdiction.

NOTE: WAGE CAP - Double the straight time hourly base wage shall be the maximum hourly wage compensation for any hour worked. Contractor is still responsible to pay the hourly benefit amount for each hour worked.



**HOLIDAY**

Paid: See ( 5, 6, 8, 13, 25 ) on HOLIDAY PAGE plus Governor of NYS Election Day.  
 Overtime: See ( 5, 6, 8, 13, 25 ) on HOLIDAY PAGE plus Governor of NYS Election Day.

NOTE: All paid holidays falling on Saturday shall be observed on the preceding Friday. All paid holidays falling on Sunday shall be observed on the following Monday. Supplements for holidays paid at straight time.

**REGISTERED APPRENTICES**

WAGES per hour: 1000 hour terms at the following percentage of the applicable Journeyman Lineman wage.

1st	2nd	3rd	4th	5th	6th	7th
60%	65%	70%	75%	80%	85%	90%

SUPPLEMENTAL BENEFITS per hour:

07/01/2023	05/06/2024
\$ 26.40	\$ 26.90
*plus 7% of the hourly wage paid	*plus 7% of the hourly wage paid

\*The 7% is based on the hourly wage paid, straight time or premium time.

6-1249a-LT

**Lineman Electrician - Tree Trimmer**

**06/01/2024**

**JOB DESCRIPTION** Lineman Electrician - Tree Trimmer

**DISTRICT** 6

**ENTIRE COUNTIES**

Albany, Allegany, Broome, Cattaraugus, Cayuga, Chautauqua, Chemung, Chenango, Clinton, Columbia, Cortland, Delaware, Dutchess, Erie, Essex, Franklin, Fulton, Genesee, Greene, Hamilton, Herkimer, Jefferson, Lewis, Livingston, Madison, Monroe, Montgomery, Niagara, Oneida, Onondaga, Ontario, Orange, Orleans, Oswego, Otsego, Putnam, Rensselaer, Rockland, Saratoga, Schenectady, Schoharie, Schuyler, Seneca, St. Lawrence, Steuben, Sullivan, Tioga, Tompkins, Ulster, Warren, Washington, Wayne, Wyoming, Yates

**WAGES**

Applies to line clearance, tree work and right-of-way preparation on all new or existing energized overhead or underground electrical, telephone and CATV lines. This also would include stump removal near underground energized electrical lines, including telephone and CATV lines.

Per hour:	07/01/2023	12/31/2023
Tree Trimmer	\$ 29.80	\$ 31.44
Equipment Operator	26.35	27.80
Equipment Mechanic	26.35	27.80
Truck Driver	21.95	23.15
Groundman	18.07	19.07
Flag person	14.20	14.20*

\*NOTE- Rate effective on 01/01/2024 - \$15.00 due to minimum wage increase

**SUPPLEMENTAL BENEFITS**

Per hour:

	07/01/2023	12/31/2023
Journeyman	\$ 10.48	\$ 10.48
	*plus 4.5% of the hourly wage paid	*plus 4.5% of the hourly wage paid

\* The 4.5% is based on the hourly wage paid, straight time rate or premium rate.

**OVERTIME PAY**

See (B, E, Q, X) on OVERTIME PAGE

NOTE: WAGE CAP - Double the straight time hourly base wage shall be the maximum hourly wage compensation for any hour worked. Contractor is still responsible to pay the hourly benefit amount for each hour worked.

**HOLIDAY**

Paid: See (5, 6, 8, 15) on HOLIDAY PAGE  
 Overtime: See (5, 6, 8, 15, 16, 25) on HOLIDAY PAGE

NOTE: All paid holidays falling on a Saturday shall be observed on the preceding Friday. All paid holidays falling on a Sunday shall be observed on the following Monday.

**Mason - Building**

**06/01/2024**

**JOB DESCRIPTION** Mason - Building

**DISTRICT** 12

**ENTIRE COUNTIES**

Herkimer, Jefferson, Lewis, Oneida, St. Lawrence

**PARTIAL COUNTIES**

Madison: Entire County except the Townships of Sullivan & Cazenovia

**WAGES**

Per hour 07/01/2023

Tile/Marble/Terrazzo

Setter	\$ 34.60
Finisher	27.52

NOTE - The "Employer Registration" (30.1) use of a '4 Day/10 Hour Work schedules' will no longer be accepted or processed. All registered projects prior to June 30,2023 will expire within the granted time frame.

For Pre-Registered Projects Four (4), Ten (10) hour days may be worked at straight time during a week, Monday thru Thursday. Friday may be used as a make-up day. Tuesday thru Friday may be worked with no make-up day. For further clarification contact your local Bureau Office.

**SUPPLEMENTAL BENEFITS**

Per hour worked

Journeyman Setters	\$ 19.71
Journeyman Finishers	19.06

**OVERTIME PAY**

See (B, E, E2, Q) on OVERTIME PAGE

**HOLIDAY**

Paid: See (1) on HOLIDAY PAGE  
 Overtime: See (5, 6) on HOLIDAY PAGE

**REGISTERED APPRENTICES**

Wages per hour

Hour terms at the following percentage of journeyman's wage

Setter:

1st term 500 hours	60%
2nd term 1000 hours	70%
3rd term 1000 hours	80%
4th term 1000 hours	85%
5th term 1000 hours	90%
6th term 1500 hours	95%

Finisher;

1st term 500 HOURS	70%
2ND term 1000 HOURS	80%
3RD term 1000 HOURS	90%
4TH term 1200 HOURS	95%

Supplemental Benefits per hour worked

Setter:

1st & 2nd Term	\$ 12.16
3rd & 4th Term	15.93
5th Term	17.82
6th Term	19.71

Finishers:

1st & 2nd Term	\$ 11.57
All others	15.31

**Mason - Building** **06/01/2024**

**JOB DESCRIPTION** Mason - Building

**DISTRICT** 12

**ENTIRE COUNTIES**

Herkimer, Oneida

**PARTIAL COUNTIES**

Lewis: The townships of Lewis, Leyden, Osceola, Turin and West Turin  
 Madison: Entire County except the Townships of Sullivan and Cazenovia

**WAGES**

Per hour 07/01/2023

Bricklayer/Blocker	\$ 38.44
Cement Mason(Bldg)	38.44
Plasterer/Fireproofing*	38.84
Stone Mason	38.84
Concrete Cutter	38.84
Pointer/Caulker/Cleaner	38.84

Additional \$.25 per hr. for work in restricted radiation area of atomic plant.

Additional \$5.00 per day more for employees working on a two-point suspension scaffold (Pointer, Caulker, and Cleaner are excluded).

(\*Fireproofers on Structural only.

NOTE - The "Employer Registration" (30.1) use of a '4 Day/10 Hour Work schedules' will no longer be accepted or processed. All registered projects prior to June 30,2023 will expire within the granted time frame.

For Pre-Registered Projects Four (4), Ten (10) hour days may be worked at straight time during a week, Monday thru Thursday. Friday may be used as a make-up day. Tuesday thru Friday may be worked with no make-up day. For further clarification contact your local Bureau Office.

**SUPPLEMENTAL BENEFITS**

Per hour worked

Journeyman \$ 21.18

**OVERTIME PAY**

See (B, E, E2, Q) on OVERTIME PAGE

**HOLIDAY**

Paid: See (1) on HOLIDAY PAGE  
 Overtime: See (5, 6) on HOLIDAY PAGE

**REGISTERED APPRENTICES**

Wages per hour

750 hour terms at the following percentage of Journey's wage

1st	2nd	3rd	4th	5th	6th	7th	8th
60%	60%	65%	70%	75%	80%	85%	90%

Supplemental Benefits per hour worked:

All Terms \$21.18

12-2b.2

**Mason - Heavy&Highway** **06/01/2024**

**JOB DESCRIPTION** Mason - Heavy&Highway

**DISTRICT** 12

**ENTIRE COUNTIES**

Albany, Cayuga, Clinton, Columbia, Essex, Franklin, Fulton, Greene, Hamilton, Herkimer, Jefferson, Lewis, Madison, Montgomery, Oneida, Oswego, Rensselaer, Saratoga, Schenectady, Schoharie, St. Lawrence, Warren, Washington

**PARTIAL COUNTIES**

Onondaga: For Heavy & Highway Cement Mason or Plaster Work in Onondaga County, refer to Mason-Heavy&Highway tag 1-2h/h on.

**WAGES**

Per hour 07/01/2023

Mason & Bricklayer	\$ 41.46
--------------------	----------

Additional \$1.00 per hour for work on any swing scaffold or staging suspended by means of ropes or cables.

**SUPPLEMENTAL BENEFITS**

Per hour worked

Journeyman

\$ 21.98

**OVERTIME PAY**

See (B, E, E2, Q) on OVERTIME PAGE

**HOLIDAY**

Paid: See (1) on HOLIDAY PAGE

Overtime: See (5, 6) on HOLIDAY PAGE

Note: If a holiday falls on Sunday, the Monday following shall constitute the day of the legal holiday.

**REGISTERED APPRENTICES**

Wages per hour

750 HR TERMS at the following percent of Journeyman's wage

1st	2nd	3rd	4th	5th	6th	7th	8th
60%	60%	65%	70%	75%	80%	85%	90%

Supplemental Benefits per hour worked

0 to 500 Hours	\$ 13.38
All Other	21.98

12-2hh.1

**Millwright**

**06/01/2024**

**JOB DESCRIPTION** Millwright

**DISTRICT 6**

**ENTIRE COUNTIES**

Albany, Allegany, Broome, Cattaraugus, Cayuga, Chautauqua, Chemung, Chenango, Clinton, Columbia, Cortland, Delaware, Erie, Essex, Franklin, Fulton, Genesee, Greene, Hamilton, Herkimer, Jefferson, Lewis, Livingston, Madison, Monroe, Montgomery, Niagara, Oneida, Onondaga, Ontario, Orleans, Oswego, Otsego, Rensselaer, Saratoga, Schenectady, Schoharie, Schuyler, Seneca, St. Lawrence, Steuben, Sullivan, Tioga, Tompkins, Ulster, Warren, Washington, Wayne, Wyoming, Yates

**WAGES**

THE FOLLOWING RATE APPLIES TO ANY GAS/STEAM TURBINE AND OR RELATED COMPONENT WORK, INCLUDING NEW INSTALLATIONS OR MAINTENANCE AND ANY/ALL WORK PERFORMED WITHIN THE PROPERTY LIMITS OF A NUCLEAR FACILITY.

Per hour:	07/01/2023	07/01/2024	07/01/2025
		Additional	Additional
Millwright - Power Generation	\$ 43.05	\$ 2.50	\$2.50

NOTE: ADDITIONAL PREMIUMS PAID FOR THE FOLLOWING WORK LISTED BELOW (amount subject to any overtime premiums):

- Certified Welders shall receive an additional \$1.75 per hour provided he/she is directed to perform certified welding.
- If a work site has been declared a hazardous site by the Owner and the use of protective gear (including, as a minimum, air purifying canister-type chemical respirators) are required, then that employee shall receive an additional \$1.50 per hour.
- An employee performing the work of a machinist shall receive an additional \$2.00 per hour. For the purposes of this premium to apply, a "machinist" is a person who uses a lathe, Bridgeport, milling machine or similar type of tool to make or modify parts.
- When performing work underground at 500 feet and below, the employee shall receive an additional \$1.00 per hour.

**SUPPLEMENTAL BENEFITS**

Per hour paid:

Journeyman \$ 27.40\*

\*NOTE: Subject to OT premium

**OVERTIME PAY**

See (B, E, E2, Q, V) on OVERTIME PAGE

**HOLIDAY**

Paid: See (1) on HOLIDAY PAGE

Overtime: See (5, 6) on HOLIDAY PAGE

NOTE: Any holiday that falls on Sunday shall be observed the following Monday. Any holiday that falls on Saturday shall be observed the preceding Friday.

**REGISTERED APPRENTICES**

WAGES per hour: One year terms at the following percentage of Journeyman's wage:

Appr. 1st year	65 %*
Appr. 2nd year	75 %*
Appr. 3rd year	80 %*
Appr. 4th year	90 %*

\*NOTE: Additional premium for the following work listed below:

Certified Welder	\$ 1.75
Hazardous Waste Work	1.50
Machinist	2.00
Underground (500' and below)	1.00

SUPPLEMENTAL BENEFITS per hour:

Appr. 1st year	\$ 11.89
Appr. 2nd year	22.75
Appr. 3rd year	24.30
Appr. 4th year	25.85

6-1163Power

<b>Millwright</b>	<b>06/01/2024</b>
-------------------	-------------------

**JOB DESCRIPTION** Millwright

**DISTRICT 2**

**ENTIRE COUNTIES**

Clinton, Essex, Franklin, Hamilton, Jefferson, Lewis, Oneida, Onondaga, Oswego, St. Lawrence, Warren, Washington

**WAGES**

Per hour:	07/01/2023	07/01/2024 Additional	07/01/2025 Additional
Building	\$ 34.32	\$ 3.00*	\$ 3.00*
Heavy & Highway	37.32	3.50*	3.00

\*To be allocated at a later date

NOTE ADDITIONAL PREMIUMS PAID FOR THE FOLLOWING WORK LISTED BELOW (amount subject to any overtime premiums):

- Certified Welders shall receive \$1.75 per hour in addition to the current Millwrights rate provided he/she is directed to perform certified welding.
- For Building work if a work site has been declared a hazardous site by the Owner and the use of protective gear (including, as a minimum, air purifying canister-type chemical respirators) are required, then that employee shall receive a \$1.50 premium per hour for Building work.
- For Heavy & Highway work if the work is performed at a State or Federally designated hazardous waste site where employees are required to wear protective gear, the employees performing the work shall receive an additional \$2.00 per hour over the millwright heavy and highway wage rate for all hours worked on the day protective gear was worn.
- An employee performing the work of a machinist shall receive \$2.00 per hour in addition to the current Millwrights rate. For the purposes of this premium to apply, a "machinist" is a person who uses a lathe, Bridgeport, milling machine or similar type of tool to make or modify parts.
- When performing work underground at 500 feet and below, the employee shall receive an additional \$1.00.

**SUPPLEMENTAL BENEFITS**

Per hour:

Journeyman	\$ 25.59
------------	----------

**OVERTIME PAY**

See (B, E, E2, Q) on OVERTIME PAGE

**HOLIDAY**

Paid: See (1) on HOLIDAY PAGE  
 Overtime: See (5, 6) on HOLIDAY PAGE

Note: Any holiday that falls on Sunday shall be observed the following Monday. Any holiday that falls on Saturday shall be observed the preceding Friday.

**REGISTERED APPRENTICES**

Wages per hour:

(1)year terms at the following percentage of Journeyman's rate.

1st	2nd	3rd	4th
65%	75%	80%	90%

Supplemental Benefits per hour:

Apprentices:

1st term	\$ 11.74
2nd term	21.44
3rd term	22.82
4th term	24.21

2-1163.2

**Operating Engineer - Building**

**06/01/2024**

**JOB DESCRIPTION** Operating Engineer - Building

**DISTRICT 6**

**ENTIRE COUNTIES**

Cayuga, Cortland, Jefferson, Lewis, Madison, Oneida, Onondaga, Oswego, Seneca, St. Lawrence, Tompkins

**WAGES**

**NOTE:**

---If a prime contract is let for site work only, meaning no buildings are involved in their site contract, the Heavy/Highway rates would be applicable. When a prime contract is let for site work and building excavation is part of that contract, the Building rates would be applicable for the Operators classification.

---In the event that equipment listed below is operated by robotic control, the classification covering the operation will be the same as if manually operated.

---If a second employee is required by the employer for operation of any covered machine, they shall be an Engineer Class C.

CLASS A1\*: Cranes, All types (A1 Includes Boom Truck, Cableway, Cherry Picker, Derrick, Dragline, Dredge, Overhead Crane, Pile Driver, Tower Crane, Truck Crane, Whirlies)

CLASS A: Air Plako, Asphalt & Blacktop Roller, Automated Concrete Spreader (CMI or equivalent), Automated Fine Grade Machine (CMI), Backhoe, Barrel Shredder, Belt Placer, Blacktop Spreader (such as Barber-Greene & Blaw Knox), Blacktop Plant (automated), Blast or Rotary Drill (Truck or Cat mounted), Burning Plant Operator, Caisson Auger, Central Mix Plant (automated), Concrete Pump, Crusher (Rock), De-watering Press, Diesel Power Unit, Dirt Filter Press with Operation Equipment, Dual Drum Paver, Elevating Grader (self-propelled or towed), Elevator Hoist - Two Cage, Excavator - all purpose hydraulically operated, Fork Lift (Loed/Lull and other rough terrain type), Front End Loader (4 c.y. and over), Gradall, Grader (Power), Head Tower (Saurman or equal), Hoist (2 or 3 Drum), Hydroblaster (Laser Pump), Light Plants - Compressors and Generators, Locomotive, Maintenance Engineer, Maintenance Welder, Mine Hoist, Mucking Machine or Mole, Quarry Master or Equivalent, Refrigeration Equipment (for soil stabilization), Scraper, Sea Mule, Shovel, Side Boom, Slip Form Paver, Straddle Buggy (Ross Carrier, Lumber Carrier), Tractor Drawn Belt Type Loader (Euclid Loader), Trenching Machine (digging capacity of over 4ft. depth), Truck or Trailer Mounted Log Chipper (self-feeder), Tug Operator (Manned, rented equipment excluded), Tunnel Shovel, Vibro or Sonic Hammer Controls (when not mounted in proximity to Rig Operator), Work Boat Operator including LCM's.

CLASS B: "A" Frame Truck, Back Dumps, Blacktop Plant (non-automatic), Boring Machine, Bulldozer, Cage-Hoist, Central Mix Plant (non-automated), Compressor, Pump, Generator or Welding machine (when used in battery of not more than five (5)), Concrete Paver (single drum over 16'), Core boring machine, Drill Rigs - tractor mounted, Elevator - as material hoist, Farm Tractor (with or without accessories), Fork Lift (over 10 ton with or without attachments), Front End Loader (under 4 c.y.), Grout Pump, Gunit Machine, High Pressure Boiler (15 lbs. & over), Hoist (one drum), Hydraulic Breaking Hammer (Drop Hammer), Kolman Plant Loader (screening gravel), Maintenance Grease Man, Mixer for stabilized base - self-propelled (Seaman Mixer), Monorail Machine, Parapet Concrete or Pavement Grinder, Parts Man, Post Driver (truck or tractor mounted), Post Hole Digger (truck or tractor mounted), Power Sweeper (Wayne or similar), Pump-Crete or Squeeze-Crete, Road Widener (front end of Grader or self-propelled), Roller, Self-contained hydraulic bench drill, Shell Winder (motorized), Skid steer (Bobcat type loader), Snorkel (overhead arms), Snowblower control man, Tractor (with or without accessories), Trenching Machine (digging capacity of 4 ft. or less), Tugger Hoist, Vacuum Machine (self-propelled or mounted), Vibro Tamp, Well Drill / Well Point System (Submersible pumps when used in lieu of Well Point System), Winch (Motor driven), Winch Cat, Winch Truck

CLASS C: Compressor (up to 500 cfm), Concrete Paver or Mixer (under 16'), Concrete Pavement Spreaders & Finishers (not automated), Conveyor (over 12 ft), Electric Submersible Pump (4" and over), Fine Grade Machine (not automated), Fireman, Fork Lift ("with or without" attachments, 10 ton and under), Form Tamper, Generator (2,500 watts and over), Hydraulic Pump, Mechanical Heaters (More than two (2) Mechanical Heaters or any Mechanical Heater or Heaters whose combined output exceeds 640,000 BTU per hour (manufacturer's rating) plus one self-contained heating unit - i.e. Sundog or Air Heat type - New Holland Hay Dryer type excluded), Mulching Machine, Oiler, Power Driven Welding Machine (300 amp and over, other than all electric. One Welding Machine under 300 amp will not require an engineer unless in a battery), Power Heaterman (hay dryer), Pumps (water and trash), Revinus Widener (road widener), Single Light Plant, Steam Cleaner or Jenny.

Per hour: Building	07/01/2023	07/01/2024	07/01/2025
Class A1*	\$ 45.75	\$ 47.62	\$ 49.61
Class A	44.25	46.12	48.11
Class B	42.13	44.00	45.99
Class C	37.91	39.78	41.77

Additional \$2.50 per hour if work requires Personal Protective Equipment for hazardous waste site activities with a level C or over rating.

(\*) TONNAGE PREMIUMS:

All cranes 65 ton to 110 ton capacity - A1 rate plus \$ 1.50  
 All cranes 111 ton to 199 ton capacity - A1 rate plus \$ 2.00  
 All cranes 200 ton to 399 ton capacity - A1 rate plus \$ 3.00  
 All cranes 400 ton to 599 ton capacity - A1 rate plus \$ 4.00  
 All cranes 600 ton to 799 ton capacity - A1 rate plus \$ 5.00  
 All cranes 800 ton to 999 ton capacity - A1 rate plus \$ 6.00  
 All cranes 1000 ton capacity and over - A1 rate plus \$ 7.00

**SUPPLEMENTAL BENEFITS**

Per hour:

Journeyman	\$ 29.91	\$ 31.02	\$ 32.12
------------	----------	----------	----------

**OVERTIME PAY**

See (B, E, Q) on OVERTIME PAGE

**HOLIDAY**

Paid: See (5, 6) on HOLIDAY PAGE

Overtime: See (5, 6) on HOLIDAY PAGE

NOTE: If the holiday falls on Sunday, it will be celebrated on Monday.

**REGISTERED APPRENTICES**

WAGES per hour: One thousand hour terms at the following percentage of Journeyman's CLASS A wage:

1st year	60%
2nd year	65%
3rd year	70%
4th year	80%

Additional \$2.50 per hour if work requires Personal Protective Equipment for hazardous waste site activities with a level C or over rating.

SUPPLEMENTAL BENEFITS per hour:

	07/01/2023	07/01/2024	07/01/2025
All Terms:	\$ 29.85	\$ 30.95	\$ 32.05

6-158-545b.s

**Operating Engineer - Heavy&Highway**

**06/01/2024**

**JOB DESCRIPTION** Operating Engineer - Heavy&Highway

**DISTRICT 6**

**ENTIRE COUNTIES**

Cayuga, Cortland, Jefferson, Lewis, Madison, Oneida, Onondaga, Oswego, Seneca, St. Lawrence, Tompkins

**WAGES**

NOTE:

---In the event that equipment listed below is operated by robotic control, the classification covering the operation will be the same as if manually operated.

---If a second employee is required by the employer for operation of any covered machine, they shall be an Engineer Class C

CLASS A1\*: Cranes, All types (Boom Truck, Cherry Picker, Derrick, Dragline, Overhead Crane (Gantry or Straddle Type), Pile Driver, Tower Crane (including self erecting), Truck Crane)

CLASS A: Asphalt Curb Machine (self-propelled, slipform); Asphalt Paver; Automated Concrete Spreader (CMI type); Automatic Fine Grader; Backhoe (except tractor mounted, rubber tired); Backhoe Excavator, Full Swing (CAT 212 or similar type); Back Filling Machine; Belt Placer (CMI type); Blacktop Plant (automated);Blacktop Roller; Cableway; Bull Dozer being operated with active GPS; Caisson Auger; Central Mix Concrete Plant (automated); Concrete Curb Machine (self-propelled, slipform); Concrete Pump; Directional Boring/Drilling Machine; Dredge; Dual Drum Paver; Excavator (all purpose-hydraulic, Gradall or similar); Front End Loader (4 cu. yd. & over); Head Tower (Sauerman or equal); Hoist (two or three drum); Holland Loader; Maintenance Engineer; Mine Hoist; Mucking Machine or Mole; Pavement Breaker (SP Wertgen; PB-4 and similar type); Profiler (over 105 h.p.); Power Grader; Quad 9; Quarry Master (or equivalent); Rotating Telehandler; Scraper (including challenger type); Shovel; Slip Form Paver; Tractor Drawn Belt-Type Loader; Truck or Trailer Mounted Chipper (self-feeder); Tug Operator (manned rented equipment excluded); Tunnel Shovel

CLASS B: Backhoe (tractor mounted, rubber tired); Bituminous Recycler Machine; Bituminous Spreader and Mixer; Blacktop Plant (non-automated); Blast or Rotary Drill (truck or tractor mounted); Boring Machine; Bridge Deck Finishing Machine; Brokk; Cage Hoist; Central Mix Plant (non-automated) and All Concrete Batching Plants; Concrete Paver (over 16'); Crawler Drill (self-contained); Crusher; Diesel Power Unit; Drill Rigs (truck or tractor mounted); Front End Loader (under 4 cu. yd.); Greaseman - Lubrication Engineer; HiPressure Boiler (15 lbs & over); Hoist (one drum); Hydro-Axe; Kolman Plant Loader & similar type loaders; Locomotive; Material Handling Knuckle Boom; Mini Excavators (under 18,000 lbs.); Mixer (for stabilized base, self-propelled); Monorail Machine; Profiler (105 h.p. and under); Plant Engineer; Prentice Loader; Pug Mill; Pump Crete; Ready Mix Concrete Plant; Refrigeration Equipment (for soil stabilization); Road Widener; Roller (all above subgrade, See Class A for Blacktop Roller); Sea Mule; Self-contained ride-on Rock Drill (excluding Air-Track type drill); Skidder; Tractor with Dozer and/or Pusher; Trencher; Tugger Hoist; Vacuum Machine (mounted or towed); Vermeer Saws (ride-on, any size or type); Welder; Winch and Winch Cat; Work Boat Operator including L.C.M.'s

CLASS C: "A" Frame Winch Hoist (On Truck); Aggregate Plant; Articulated Heavy Hauler; Asphalt or Concrete Grooving Machine (ride-on); Ballast Regulator (ride-on); Bituminous Heater (self-propelled); Boat (powered); Boiler (used in conjunction with production); Cement & Bin Operator; Compressors\*\*; Concrete Pavement Spreader and Finisher; Concrete Paver or Mixer (16' & under); Concrete Saw (self-propelled); Conveyor; Deck Hand; Directional Boring/Drilling Machine Locator; Drill (Core); Drill (Well); Dust Collectors\*\*; Electric Pump When Used in Conjunction with Well Point System; Farm Tractor with accessories; Fine Grade Machine; Fireman; Fork Lift; Form Tamper; Generators\*\*; Grout Pump; Guniting Machine; Hammers (hydraulic self-propelled); Heaters\*\*; Hydra-Spiker (ride-on); Hydraulic Pump (jacking system); Hydro-Blaster (water); Light Plants\*\*; Mulching Machine; Oiler; Parapet Concrete or Pavement Grinder; Post Hole Digger (excluding hand-held); Post Driver; Power Broom (towed); Power Heaterman; Power Sweeper; Pumps\*\*; Revinus Widener; Roller (subgrade & fill); Scarifier (ride-on); Shell Winder; Skid Steer Loader (Bobcat or similar, including all attachments); Span Saw (ride-on); Steam Cleaner; Tamper (ride-on); Tie Extractor (ride-on); Tie Handlers (ride-on); Tie Inserters (ride-on); Tie Spacers (ride-on); Tire Repair; Track Liner (ride-on); Tractor; Tractor (with towed accessories); Vacuum Machine (self-propelled); Vibratory Compactor; Vibro Tamp; Welding Machines\*\*; Well Point

\*\*CLASS C NOTE: Considered Hands-Off (unmanned). Includes only operation and maintenance of the equipment.

Per hour: H/H	07/01/2023	07/01/2024	07/01/2025
CLASS A1*	\$ 54.30	\$ 56.51	\$ 58.85
CLASS A	51.30	53.51	55.85
CLASS B	50.42	52.63	54.97
CLASS C	47.14	49.35	51.69

(\*) TONNAGE PREMIUMS:

- All cranes 65 ton to 110 ton capacity - A1 rate plus \$ 1.50
- All cranes 111 ton to 199 ton capacity- A1 rate plus \$ 2.00
- All cranes 200 ton to 399 ton capacity - A1 rate plus \$ 3.00
- All cranes 400 ton to 599 ton capacity - A1 rate plus \$ 4.00
- All cranes 600 ton to 799 ton capacity - A1 rate plus \$ 5.00
- All cranes 800 ton to 999 ton capacity - A1 rate plus \$ 6.00
- All cranes 1000 ton capacity and over - A1 rate plus \$ 7.00

- Cranes in Luffer Configuration - A1 rate plus \$ 5.00
- Cranes with external ballast (Tray or Wagon) - A1 rate plus \$ 5.00

Additional \$2.50 per hour for hazardous waste removal work on a State and/or Federally designated waste site which requires employees to wear Level C or above forms of personal protection.

SINGLE IRREGULAR WORK SHIFT: Additional \$2.50 per hour for all employees who work a single irregular work shift starting from 5:00 PM to 1:00 AM that is mandated by the Contracting Agency.

NOTE - The "Employer Registration" (30.1) use of a '4 Day/10 Hour Work schedules' will no longer be accepted or processed. All registered projects prior to June 30, 2023 will expire within the granted time frame.

For Pre-Registered Projects Four (4), Ten (10) hour days may be worked at straight time during a week, Monday thru Thursday. Friday may be used as a make-up day. Tuesday thru Friday may be worked with no make-up day. For further clarification contact your local Bureau Office.

**SUPPLEMENTAL BENEFITS**

Per hour:	07/01/2023	07/01/2024	07/01/2025
Journeyman	\$ 31.35	\$ 32.45	\$ 33.55

**OVERTIME PAY**

See (B, E, Q) on OVERTIME PAGE

**HOLIDAY**

Paid: See (5, 6) on HOLIDAY PAGE  
 Overtime: See (5, 6) on HOLIDAY PAGE



NOTE: If a holiday falls on Sunday, it will be celebrated on Monday. If an employee works on this Monday, they shall be compensated at double time plus the holiday pay (triple time). If a holiday falls on a Saturday, employees who work a Saturday Holiday shall be paid double time plus the holiday pay.

**REGISTERED APPRENTICES**

WAGES per hour: One thousand hour terms at the following percentage of Journeyman's CLASS B wage.

1st term	60%
2nd term	70%
3rd term	80%
4th Term	90%

Additional \$2.50 per hour for hazardous waste removal work on a State and/or Federally designated waste site which requires employees to wear Level C or above forms of personal protection.

SUPPLEMENTAL BENEFITS per hour: Same as Journeyman

6-158-545h

**Operating Engineer - Survey Crew**

**06/01/2024**

**JOB DESCRIPTION** Operating Engineer - Survey Crew

**DISTRICT** 12

**ENTIRE COUNTIES**

Albany, Allegany, Broome, Cayuga, Chemung, Chenango, Clinton, Columbia, Cortland, Essex, Franklin, Fulton, Greene, Hamilton, Herkimer, Jefferson, Lewis, Livingston, Madison, Monroe, Montgomery, Oneida, Onondaga, Ontario, Oswego, Otsego, Rensselaer, Saratoga, Schenectady, Schoharie, Schuyler, Seneca, St. Lawrence, Steuben, Tioga, Tompkins, Warren, Washington, Wayne, Yates

**PARTIAL COUNTIES**

Dutchess: The northern portion of the county from the northern boundary line of the City of Poughkeepsie, north.

Genesee: Only the portion of the county that lies east of a line down the center of Route 98 to include all area that lies within the City of Batavia.

**WAGES**

These rates apply to Building, Tunnel and Heavy Highway.

Per hour:

**SURVEY CLASSIFICATIONS:**

Party Chief - One who directs a survey party.

Instrument Person - One who operates the surveying instruments.

Rod Person - One who holds the rods and assists the Instrument Person.

07/01/2023

Party Chief	\$ 48.97
Instrument Person	44.99
Rod Person	33.37

Additional \$3.00/hr. for Tunnel Work

Additional \$2.50/hr. for Hazardous Work Site

**SUPPLEMENTAL BENEFITS**

Per hour worked:

Journeyman	\$ 28.90
------------	----------

**OVERTIME PAY**

See (B, E, P, \*X) on OVERTIME PAGE

\*Note: \$24.60/Hr. Only for "ALL" premium hours paid when worked.

**HOLIDAY**

Paid: See (5, 6) on HOLIDAY PAGE

Overtime: See (5, 6) on HOLIDAY PAGE

**REGISTERED APPRENTICES**

WAGES: 1000 hour terms based on the Percentage of Rod Persons Wage:

07/01/2023

0-1000	60%
1001-2000	70%
2001-3000	80%

SUPPLEMENTAL BENEFIT per hour worked:

0-1000	\$ 20.68 / PHP \$17.53
1001-2000	23.70 / " 19.95
2001-3000	26.73 / " 22.43

NOTE: PHP is premium hours paid when worked.

12-158-545 D.H.H.

**Operating Engineer - Survey Crew - Consulting Engineer**

**06/01/2024**

**JOB DESCRIPTION** Operating Engineer - Survey Crew - Consulting Engineer

**DISTRICT** 12

**ENTIRE COUNTIES**

Albany, Allegany, Broome, Cayuga, Chemung, Chenango, Clinton, Columbia, Cortland, Essex, Franklin, Fulton, Greene, Hamilton, Herkimer, Jefferson, Lewis, Livingston, Madison, Monroe, Montgomery, Oneida, Onondaga, Ontario, Oswego, Otsego, Rensselaer, Saratoga, Schoenectady, Schoharie, Schuyler, Seneca, St. Lawrence, Steuben, Tioga, Tompkins, Warren, Washington, Wayne, Yates

**PARTIAL COUNTIES**

Dutchess: The northern portion of the county from the northern boundary line of the City of Poughkeepsie, north.

Genesee: Only the portion of the county that lies east of a line down the center of Route 98 to include all area that lies within the City of Batavia.

**WAGES**

These rates apply to feasibility and preliminary design surveying, line and grade surveying for inspection or supervision of construction when performed under a Consulting Engineer Agreement.

Per hour:

**SURVEY CLASSIFICATIONS:**

Party Chief - One who directs a survey party.

Instrument Person - One who operates the surveying instruments.

Rod Person - One who holds the rods and assists the Instrument Person.

07/01/2023

Party Chief	\$ 48.97
Instrument Person	44.99
Rod Person	33.37

Additional \$3.00/hr. for Tunnel Work.

Additional \$2.50/hr. for EPA or DEC certified toxic or hazardous waste work.

**SUPPLEMENTAL BENEFITS**

Per hour worked:

Journeyman \$ 28.90

**OVERTIME PAY**

See (B, E, Q, \*X) on OVERTIME PAGE

\*Note: \$24.10/Hr. Only for "ALL" premium hours paid when worked.

**HOLIDAY**

Paid: See (5, 6) on HOLIDAY PAGE

Overtime: See (5, 6) on HOLIDAY PAGE

**REGISTERED APPRENTICES**

WAGES: 1000 hour terms based on percentage of Rod Persons Wage:

07/01/2023

0-1000	60%
1001-2000	70%
2001-3000	80%

SUPPLEMENTAL BENEFIT per hour worked:

0-1000	\$ 20.68 / PHP \$17.53
1001-2000	\$ 23.70 / " 19.95
2001-3000	\$ 26.73 / " 22.43

NOTE: PHP is premium hours paid when worked.

12-158-545 DCE

**Operating Engineer - Tunnel**

**06/01/2024**

**JOB DESCRIPTION** Operating Engineer - Tunnel

**DISTRICT** 7

**ENTIRE COUNTIES**

Albany, Allegany, Broome, Cayuga, Chemung, Chenango, Clinton, Columbia, Cortland, Essex, Franklin, Fulton, Greene, Hamilton, Herkimer, Jefferson, Lewis, Livingston, Madison, Monroe, Montgomery, Oneida, Onondaga, Ontario, Oswego, Otsego, Rensselaer, Saratoga, Schenectady, Schoharie, Schuyler, Seneca, St. Lawrence, Steuben, Tioga, Tompkins, Warren, Washington, Wayne, Yates

**PARTIAL COUNTIES**

Dutchess: Northern part of Dutchess, to the northern boundary line of the City of Poughkeepie, then due east to Route 115 to Bedell Road, then east along Bedell Road to VanWagner Road, then north along VanWagner Road to Bower Road, then east along Bower Road to Rte. 44 east to Rte. 343, then along Rte. 343 east to the northern boundary of the Town of Dover Plains and east along the northern boundary of the Town of Dover Plains, to the borderline of the State of Connecticut.

Genesee: Only that portion of the county that lies east of a line drawn down the center of Route 98 and the entirety of the City of Batavia.

**WAGES**

CLASS A: Automatic Concrete Spreader (CMI Type); Automatic Fine Grader; Backhoe (except tractor mounted, rubber tired); Belt Placer (CMI Type); Blacktop Plant (automated); Cableway; Caisson Auger; Central Mix Concrete Plant (automated); Concrete Curb Machine (self-propelled slipform); Concrete Pump (8" or over); Dredge; Dual Drum Paver; Excavator; Front End Loader (4 cu. yd & over); Gradall; Head Tower (Sauerman or Equal); Hoist (shaft); Hoist (two or three Drum); Log Chipper/Loader (self-feeder); Maintenance Engineer (shaft and tunnel); any Mechanical Shaft Drill; Mine Hoist; Mining Machine(Mole and similar types); Mucking Machine or Mole; Overhead Crane (Gantry or Straddle Type); Pile Driver; Power Grader; Remote Controlled Mole or Tunnel Machine; Scraper; Shovel; Side Boom; Slip Form Paver (If a second man is needed, they shall be an Oiler); Tripper/Maintenance Engineer (shaft & tunnel); Tractor Drawn Belt-Type Loader; Tug Operator (manned rented equipment excluded); Tunnel Shovel.

CLASS B: Automated Central Mix Concrete Plant; Backhoe (topside); Backhoe (track mounted, rubber tired); Backhoe (topside); Bituminous Spreader and Mixer, Blacktop Plant (non-automated); Blast or Rotary Drill (truck or tractor mounted); Boring Machine; Cage Hoist; Central Mix Plant(non-automated); all Concrete Batching Plants; Compressors (4 or less exceeding 2,000 c.f.m. combined capacity); Concrete Pump; Crusher; Diesel Power Unit; Drill Rigs (tractor mounted); Front End Loader (under 4 cu. yd.); Grayco Epoxy Machine; Hoist (One Drum); Hoist (2 or 3 drum topside); Knuckle Boom material handler; Kolman Plant Loader & similar type Loaders (if employer requires another person to clean the screen or to maintain the equipment, they shall be an Oiler); L.C.M. Work Boat Operator; Locomotive; Maintenance Engineer (topside); Maintenance Grease Man; Mixer (for stabilized base-self-propelled); Monorail Machine; Plant Engineer; Personnel Hoist; Pump Crete; Ready Mix Concrete Plant; Refrigeration Equipment (for soil stabilization); Road Widener; Roller (all above sub-grade); Sea Mule; Shotcrete Machine; Shovel (topside); Tractor with Dozer and/or Pusher; Trencher; Tugger Hoist; Tunnel Locomotive; Vacuum Machine (mounted or towed); Welder; Winch; Winch Cat.

CLASS C: A Frame Truck; All Terrain Telescoping Material Handler; Ballast Regulator (ride-on); Compressors (4 not to exceed 2,000 c.f.m. combined capacity; or 3 or less with more than 1200 c.f.m. but not to exceed 2,000 c.f.m.); Compressors ((any size, but subject to other provisions for compressors), Dust Collectors, Generators, Pumps, Welding Machines, Light Plants (4 or any type combination)); Concrete Pavement Spreaders and Finishers; Conveyor; Drill (core); Drill (well); Electric Pump used in conjunction with Well Point System; Farm Tractor with Accessories; Fine Grade Machine; Fork Lift; Grout Pump (over 5 cu. ft.); Gunite Machine; Hammers (hydraulic-self-propelled); Hydra-Spiker (ride-on); Hydra-Blaster (water); Hydro-Blaster; Motorized Form Carrier; Post Hole Digger and Post Driver; Power Sweeper; Roller grade & fill); Scarifer (ride-on); Span-Saw (ride-on); Submersible Electric Pump (when used in lieu of well points); Tamper (ride-on); Tie-Extractor (ride-on), Tie Handler (ride-on), Tie Inserter (ride-on), Tie Spacer (ride-on); Track Liner (ride-on); Tractor with towed accessories; Vibratory Compactor; Vibro Tamp, Well Point.

CLASS D: Aggregate Plant; Cement & Bin Operator; Compressors (3 or less not to exceed 1,200 c.f.m. combined capacity); Compressors ((any size, but subject to other provisions for compressors), Dust Collectors, Generators, Pumps, Welding Machines, Light Plants (3 or less or any type or combination)); Concrete Saw (self-propelled); Form Tamper; Greaseman; Hydraulic Pump (jacking system); Junior Engineer; Light Plants; Mulching Machine; Oiler; Parapet Concrete or Pavement Grinder; Power Broom (towed); Power Heaterman (when used for production); Revinius Widener; Shell Winder; Steam Cleaner; Tractor.

Per hour:	07/01/2023	07/01/2024	07/01/2025
CLASS A	\$ 53.52	\$ 55.91	\$ 58.44
CLASS B	52.30	54.69	57.22
CLASS C	49.51	51.90	54.43
CLASS D	46.50	48.89	51.42

Additional \$5.00 per hour for Hazardous Waste Work on a state or federally designated hazardous waste site where the Operating Engineer is in direct contact with hazardous material and when personal protective equipment is required for respiratory, skin and eye protection. Fringe benefits will be paid at the hourly wage premium.

**CRANES:**

Crane 1: All cranes, including self-erecting.

Crane 2: All Lattice Boom Cranes and all cranes with a manufacturer's rating of fifty (50) ton and over.

Crane 3: All hydraulic cranes and derricks with a manufacturer's rating of forty nine (49) ton and below, including boom trucks.

Crane 1	\$ 57.52	\$ 59.91	\$ 62.44
Crane 2	56.52	58.91	61.44
Crane 3	55.52	57.91	60.44

**SUPPLEMENTAL BENEFITS**

Per hour:

\$ 24.20	\$ 25.05	\$ 25.90
+ 9.60*	+ 9.85*	+ 10.10*

\* This portion of benefits subject to same premium rate as shown for overtime wages.

**OVERTIME PAY**

See (B, B2, E, Q, X) on OVERTIME PAGE

**HOLIDAY**

Paid: See (5, 6) on HOLIDAY PAGE  
 Overtime: See (5, 6) on HOLIDAY PAGE

If a holiday falls on Sunday, it shall be observed on Monday.

**REGISTERED APPRENTICES**

WAGES:(1000) hours terms at the following percentage of Journeyman's Class B wage.

1st term	60%
2nd term	65%
3rd term	70%
4th term	75%

SUPPLEMENTAL BENEFITS per hour: Same as Journeyman.

7-158-832TL.

**Painter**

**06/01/2024**

**JOB DESCRIPTION** Painter

**DISTRICT 6**

**ENTIRE COUNTIES**

Cayuga, Herkimer, Madison, Oneida, Onondaga, Seneca

**PARTIAL COUNTIES**

Lewis: Only the Townships of High Market, Lewis, Leyden, Lyonsdale, Osceola, Turin and West Turin.

Ontario: The City and Township of Geneva.

Oswego: Only the Townships of Amboy, Constantia, Williamstown and Oneida Lake.

**WAGES**

Per hour:	07/01/2023	05/01/2024
Basic Rate (Brush & Roll)	\$ 26.27	\$ 27.27
Sign Painting	26.27	27.27
Lead Based Paint Abatement	26.27	27.27
Drywall Taper/ Finisher	26.77	28.02
Wallcovering	26.77	28.02
Drywall Machine Operator	27.27	28.52
Spray	26.77	27.77
Parking Lot, Hwy Striping	26.77	27.77
Epoxy (Brush-Roller)	26.77	27.77
Epoxy (Spray)	26.77	27.77
Sandblasting (Operator)	26.77	27.77
Boatswain Chair	26.77	27.77
Swing Scaffold	26.77	27.77
Structural Steel	26.77	27.77
(except bridges,tanks,tunnel)		
Coal Tar epoxy	27.77	28.77
Asbestos Encapsulation	28.47	29.47

NOTE - SEE BRIDGE PAINTER RATES FOR BRIDGES, TANKS, OR TUNNELS.

NOTE: FOR ANY SHIFT WHICH STARTS PRIOR TO 6:00 AM OR AFTER 12:00 NOON, ALL EMPLOYEES WHO WORK A SINGLE IRREGULAR WORK SHIFT ON GOVERNMENTAL MANDATED WORK SHALL BE PAID AN ADDITIONAL \$2.00 PER HOUR ABOVE THE APPLICABLE WAGE SCALE.

NOTE - The "Employer Registration" (30.1) use of a '4 Day/10 Hour Work schedules' will no longer be accepted or processed. All registered projects prior to June 30, 2023 will expire within the granted time frame.

For Pre-Registered Projects Four (4), Ten (10) hour days may be worked at straight time during a week, Monday thru Thursday. Friday may be used as a make-up day. Tuesday thru Friday may be worked with no make-up day. For further clarification contact your local Bureau Office.

**SUPPLEMENTAL BENEFITS**

Per hour:

Journeyman \$ 25.82 \$ 26.53

**OVERTIME PAY**

See (B, \*F, R) on OVERTIME PAGE

\* NOTE - On exterior work only, if work was missed during the week due to inclement weather, Saturday may be worked at straight time.

**HOLIDAY**

Paid: See (1) on HOLIDAY PAGE

Overtime: See (5, 6) on HOLIDAY PAGE

NOTE: A holiday that falls on a Sunday will be celebrated on Monday. A holiday that falls on a Saturday will be celebrated on Friday.

**REGISTERED APPRENTICES**

WAGES per hour:

Painter/Decorator: 750 hour terms at the following wage rate:

1st	2nd	3rd	4th	5th	6th	7th	8th
\$ 18.00	\$ 18.50	\$ 19.00	\$ 19.50	\$ 20.00	\$ 21.00	\$ 22.00	\$ 23.00

Drywall Taper/ Finisher: 750 hour terms at the following wage rate:

1st	2nd	3rd	4th	5th	6th
\$ 20.00	\$ 20.50	\$ 21.00	\$ 21.50	\$ 22.00	\$ 23.00

SUPPLEMENTAL BENEFITS per hour:

Painter/Decorator:

1st	2nd	3rd	4th	5th	6th	7th	8th
\$ 6.50	\$ 6.50	\$ 7.50	\$ 7.50	\$ 10.50	\$ 10.50	\$ 13.00	\$ 13.00

Drywall Taper/ Finisher:

1st	2nd	3rd	4th	5th	6th
\$ 7.50	\$ 7.50	\$ 7.50	\$ 10.00	\$ 10.00	\$ 12.00

6-31

**Painter**

**06/01/2024**

**JOB DESCRIPTION** Painter

**DISTRICT 3**

**ENTIRE COUNTIES**

Allegany, Broome, Cattaraugus, Cayuga, Chautauqua, Chemung, Chenango, Cortland, Delaware, Erie, Genesee, Herkimer, Jefferson, Lewis, Livingston, Madison, Monroe, Niagara, Oneida, Onondaga, Ontario, Orleans, Oswego, Otsego, Schuyler, Seneca, St. Lawrence, Steuben, Tioga, Tompkins, Wayne, Wyoming, Yates

**WAGES**

Per hour: 07/01/2023

Bridge	\$ 42.06
Tunnel	42.06
Tank*	40.06

For Bridge Painting Contracts, ALL WORKERS on and off the bridge (including Flagmen) are to be paid Painter's Rate; the contract must be ONLY for Bridge Painting.

Tank rate applies to indoor and outdoor tanks, tank towers, standpipes, digesters, waste water treatment tanks, chlorinator tanks, etc. Covers all types of tanks including but not limited to steel tanks, concrete tanks, fiberglass tanks, etc.

Note an additional \$1.50 per hour is required when the contracting agency or project specification requires any shift to start prior to 6:00am or after 12:00 noon.

**SUPPLEMENTAL BENEFITS**

Per hour: \$ 30.89

**OVERTIME PAY**

Exterior work only See ( B, E4, F\*, R ) on OVERTIME PAGE.

All other work See ( B, F\*, R ) on OVERTIME PAGE.

\*Note - Saturday is payable at straight time if the employee misses work, except where a doctor's or hospital verification of illness is produced Monday through Friday when work was available to the employee.

**HOLIDAY**

Paid: See (1) on HOLIDAY PAGE

Overtime: See (5, 6) on HOLIDAY PAGE

**REGISTERED APPRENTICES**

Wages per hour:

750 hour terms at the following percentage of Journeyman's wage rate:

1st	2nd	3rd	4th	5th	6th
\$ 24.00	\$ 26.00	\$ 28.00	\$ 30.00	\$ 34.00	\$ 38.00

Supplemental benefits per hour:

1st	2nd	3rd	4th	5th	6th
\$ 6.60	\$ 6.95	\$ 7.30	\$ 7.65	\$ 8.00	\$ 8.35

3-4-Bridge, Tunnel, Tank

---

**Painter - Metal Polisher** **06/01/2024**

---

**JOB DESCRIPTION** Painter - Metal Polisher

**DISTRICT 8**

**ENTIRE COUNTIES**

Albany, Allegany, Bronx, Broome, Cattaraugus, Cayuga, Chautauqua, Chemung, Chenango, Clinton, Columbia, Cortland, Delaware, Dutchess, Erie, Essex, Franklin, Fulton, Genesee, Greene, Hamilton, Herkimer, Jefferson, Kings, Lewis, Livingston, Madison, Monroe, Montgomery, Nassau, New York, Niagara, Oneida, Onondaga, Ontario, Orange, Orleans, Oswego, Otsego, Putnam, Queens, Rensselaer, Richmond, Rockland, Saratoga, Schenectady, Schoharie, Schuyler, Seneca, St. Lawrence, Steuben, Suffolk, Sullivan, Tioga, Tompkins, Ulster, Warren, Washington, Wayne, Westchester, Wyoming, Yates

**WAGES**

	07/01/2023
Metal Polisher	\$ 38.18
Metal Polisher*	39.28
Metal Polisher**	42.18

\*Note: Applies on New Construction & complete renovation

\*\* Note: Applies when working on scaffolds over 34 feet.

**SUPPLEMENTAL BENEFITS**

Per Hour:	07/01/2023
Journeyworker:	
All classification	\$ 12.34

**OVERTIME PAY**

See (B, E, P, T) on OVERTIME PAGE

**HOLIDAY**

Paid: See (5, 6, 11, 15, 16, 25, 26) on HOLIDAY PAGE  
 Overtime: See (5, 6, 11, 15, 16, 25, 26) on HOLIDAY PAGE

**REGISTERED APPRENTICES**

Wages per hour:

One (1) year term at the following wage rates:

	07/01/2023
1st year	\$ 16.00
2nd year	17.00
3rd year	18.00
1st year*	\$ 16.39
2nd year*	17.44
3rd year*	18.54
1st year**	\$ 18.50
2nd year**	19.50
3rd year**	20.50

\*Note: Applies on New Construction & complete renovation

\*\* Note: Applies when working on scaffolds over 34 feet.

Supplemental benefits:

Per hour:

1st year	\$ 8.69
2nd year	8.69
3rd year	8.69

8-8A/28A-MP

---

**Plumber** **06/01/2024**

---

**JOB DESCRIPTION** Plumber

**DISTRICT 7**

**ENTIRE COUNTIES**

Herkimer, Oneida

**PARTIAL COUNTIES**

Hamilton: Only the Town of Inlet.

Lewis: Towns of Lewis, Leyden, Lyonsdale, and West Turin.

Madison: Towns of Brookfield, Eaton, Fenner, Hamilton, Lebanon, Lenox, Lincoln, Madison, Nelson, Oneida, Smithfield, and Stockbridge.

Otsego: Towns of Cherry Valley, Exeter, Middlefield, Otsego, Plainfield, Richfield, Roseboom, and Springfield.

**WAGES**

Per hour: 07/01/2023

Plumber \$ 41.40

Steamfitter 41.40

Agency-mandated shift operations:

1. Shift work shall start no earlier than 6AM Monday and will conclude no later than 9AM Saturday (overtime premiums applicable after 8 hours in a shift).

2. Single irregular shiftwork, less than 3 consecutive days will be paid at the rate of time and one-half of the regular hourly rate.

3. 3 consecutive work days or more:

First Shift - Regular hourly rate.

Second Shift - Regular hourly rate plus 12%.

Third Shift - Regular hourly rate plus 18%.

**SUPPLEMENTAL BENEFITS**

Per hour:

Journeyman \$ 14.65  
 + 17.10\*

\* This portion of the benefit is subject to the SAME PREMIUM as shown for overtime on projects over \$100 million in total construction cost (including engineering & architecture).

**OVERTIME PAY**

See (B, E, Q, \*V) on OVERTIME PAGE

\*Portion of supplemental benefits subject to V code when project cost is over \$100 million (including engineering & architecture).

**HOLIDAY**

Paid: See (1) on HOLIDAY PAGE

Overtime: See (5, 6) on HOLIDAY PAGE

If a holiday falls on Sunday, it will be observed the following day. If a holiday falls on Saturday, it will be observed that day unless so determined by the Federal Government to be celebrated on a different day.

**REGISTERED APPRENTICES**

WAGES: Yearly terms at the following percentages of Journeyman's wage.

1st	2nd	3rd	4th	5th
50%	55%	60%	70%	85%

SUPPLEMENTAL BENEFITS per hour:

1st Term: \$ 14.65  
 + 8.10\*

All others: \$ 14.65  
 + 12.64\*

\* This portion of the benefit is subject to the SAME PREMIUM as shown for overtime on projects over \$100 million in total construction cost (including engineering & architecture).

7-112n-SF

**Roofer**

**06/01/2024**

**JOB DESCRIPTION** Roofer

**DISTRICT 6**

**ENTIRE COUNTIES**

Cayuga, Cortland, Franklin, Herkimer, Jefferson, Lewis, Madison, Oneida, Onondaga, Oswego, Seneca, St. Lawrence

**WAGES**

Per hour: 07/01/2023 06/01/2024

Roofer, Waterproofer \$ 32.25 Additional \$ 2.00\*

Additional per hour:	
Green Roofing**	\$ 0.25
Pitch Removal & Appl.	1.50
Asbestos Abatement	1.50
Irregular Shift(s)***	4.00

\*To be allocated at a later date.

Does not include metal roof flashings, gravel stop, or metal roofing; See Sheetmetal Worker wage schedule.

**NOTES:**

\*\* Green Roofing is any component of green technology or living roof above the roof membrane including, but not limited to, the fabric, dirt and plantings.

\*\*\*WHEN MANDATED BY THE OWNER OR CONTRACTING AGENCY, THERE IS AN ADDITIONAL PREMIUM FOR HOURS WORKED BEFORE 5:30AM AND AFTER 5:30PM.

**SUPPLEMENTAL BENEFITS**

Per hour:	
Journeyman	\$ 25.85

Additional contribution on any Asbestos Abatement work	0.75
-----------------------------------------------------------	------

**OVERTIME PAY**

See (B, E, E2\*, Q) on OVERTIME PAGE

\*NOTE - If a holiday falls in that week and 32 hours were worked, Saturday will be paid at 1 1/2 times the rate.

**HOLIDAY**

Paid:	See (1) on HOLIDAY PAGE
Overtime:	See (5, 6) on HOLIDAY PAGE

NOTE: When any of these holidays falls on Sunday, the following day shall be observed as a holiday.

**REGISTERED APPRENTICES**

WAGES per hour: 1000 hour terms at the following percentage of the Journeyman's wage:

1st term (0 to 999)	65%
2nd term (1000 to 1999)	70%
3rd term (2000 to 2999)	75%
4th term (3000 to 3999)	85%

Additional per hour:	
Green Roofing**	\$ 0.25
Pitch Removal & Appl.	1.50
Asbestos Abatement	1.50

**SUPPLEMENTAL BENEFITS per hour:**

1st term	\$ 19.48
2nd term	21.40
3rd term	24.85
4th term	25.85

Additional contribution on any Asbestos Abatement work	\$ 0.75
-----------------------------------------------------------	---------

6-195

---

**Sheetmetal Worker** **06/01/2024**

---

**JOB DESCRIPTION** Sheetmetal Worker **DISTRICT 6**

**ENTIRE COUNTIES**  
 Cayuga, Chenango, Cortland, Herkimer, Jefferson, Lewis, Madison, Oneida, Onondaga, Oswego, St. Lawrence

**WAGES**

Per hour:	07/01/2023	05/01/2024
Sheetmetal Worker:		
** (under \$10 million)	\$ 34.25	\$ 35.25
** (over \$10 million)	\$ 35.25	\$ 36.25

\*\*For total cost of Sheetmetal contract only.



TO INCLUDE METAL ROOF FLASHINGS, GRAVEL STOP, AND METAL STANDING SEAM ROOFING.

**SUPPLEMENTAL BENEFITS**

Per hour:

Journeyman \$ 22.60 22.85

**OVERTIME PAY**

See (B, E, Q) on OVERTIME PAGE

**HOLIDAY**

Paid: See (1) on HOLIDAY PAGE

Overtime: See (5, 6) on HOLIDAY PAGE

When any holiday falls on a Saturday, the Friday before such holiday shall be recognized as the legal holiday. Any holiday falling on Sunday, the following Monday shall be recognized as the legal holiday.

**REGISTERED APPRENTICES**

WAGES per hour: One year terms at the following percentage of Journeyman's wage.

	1st	2nd	3rd	4th	5th
	45%	55%	65%	75%	85%
7/1/23	\$15.41	\$18.84	\$22.26	\$25.69	\$29.11
5/1/24	\$15.86	\$19.39	\$22.91	\$26.44	\$29.96

SUPPLEMENTAL BENEFITS per hour:

7/1/23	\$13.36	\$14.43	\$15.49	\$17.59	\$18.66
5/1/24	\$13.53	\$14.60	\$15.66	\$17.77	\$18.84

6-58

**Sprinkler Fitter**

**06/01/2024**

**JOB DESCRIPTION** Sprinkler Fitter

**DISTRICT 1**

**ENTIRE COUNTIES**

Allegany, Broome, Cattaraugus, Cayuga, Chautauqua, Chemung, Chenango, Clinton, Columbia, Cortland, Delaware, Erie, Essex, Franklin, Fulton, Genesee, Greene, Hamilton, Herkimer, Jefferson, Lewis, Livingston, Madison, Monroe, Montgomery, Niagara, Oneida, Onondaga, Ontario, Orleans, Oswego, Otsego, Schoharie, Schuyler, Seneca, St. Lawrence, Steuben, Tioga, Tompkins, Washington, Wayne, Wyoming, Yates

**WAGES**

Per hour 07/01/2023

Sprinkler \$ 40.04  
 Fitter

**SUPPLEMENTAL BENEFITS**

Per hour

Journeyman \$ 28.24

**OVERTIME PAY**

See (B, E, Q) on OVERTIME PAGE

**HOLIDAY**

Paid: See (1) on HOLIDAY PAGE

Overtime: See (5, 6) on HOLIDAY PAGE

Note: When a holiday falls on Sunday, the following Monday shall be considered a holiday and all work performed on either day shall be at the double time rate. When a holiday falls on Saturday, the preceding Friday shall be considered a holiday and all work performed on either day shall be at the double time rate.

**REGISTERED APPRENTICES**

Wages per hour

One Half Year terms at the following wage.

1st	2nd	3rd	4th	5th	6th	7th	8th	9th	10th
\$ 19.15	\$ 21.28	\$ 23.16	\$ 25.29	\$ 27.41	\$ 29.54	\$ 31.67	\$ 33.80	\$ 35.93	\$ 38.05

Supplemental Benefits per hour

1st	2nd	3rd	4th	5th	6th	7th	8th	9th	10th
\$ 8.74	\$ 8.74	\$ 20.32	\$ 20.32	\$ 20.57	\$ 20.57	\$ 20.57	\$ 20.57	\$ 20.57	\$ 20.57

1-669

**Teamster - Building** **06/01/2024**

**JOB DESCRIPTION** Teamster - Building

**DISTRICT 1**

**ENTIRE COUNTIES**

Hamilton, Herkimer, Oneida

**PARTIAL COUNTIES**

Chenango: Entire county except the Townships of Afton, Bainbridge, Coventry, Greene, Guilford, Oxford and Smithville.

Lewis: Only the Township of Grieg, Lewis, Leyden, Lowville, Lyonsdale, Martinsburg, Turin, West Turin and Watson.

Madison: Only the Townships of Brookfield, Eaton, Hamilton, Lebanon, Lincoln, Madison, Smithfield, Stockbridge and the City of Oneida

Otsego: Entire county EXCEPT Townships of Butternuts, Laurens, Maryland, Milford, Morris, Oneonta, Otego, Unidilla and Worchester.

**WAGES**

**GROUP # A:**

Straight trucks, winch, transit mix on the site, road oilers, dump trucks, pick-ups, panel, water trucks, fuel trucks on the site (including nozzle).

**GROUP # B:**

Low boy or Low boy trailer, Euclids or similar equipment.

**WAGES per hour**

	07/01/2023	07/01/2024
Group A	\$ 28.24	\$ 31.44
Group B	28.54	31.74

**SUPPLEMENTAL BENEFITS**

Per hour

Journey person	\$ 27.74	\$ 28.58
----------------	----------	----------

**OVERTIME PAY**

See (B, E, E2, Q) on OVERTIME PAGE

**HOLIDAY**

Paid: See (1) on HOLIDAY PAGE

Overtime: See (5, 6) on HOLIDAY PAGE

Note: Any holiday which occurs on Sunday shall be observed the following Monday.

1-294z2

**Teamster - Heavy&Highway** **06/01/2024**

**JOB DESCRIPTION** Teamster - Heavy&Highway

**DISTRICT 1**

**ENTIRE COUNTIES**

Albany, Columbia, Fulton, Greene, Hamilton, Herkimer, Montgomery, Oneida, Rensselaer, Saratoga, Schenectady, Schoharie, Washington

**PARTIAL COUNTIES**

Chenango: Entire county except the Townships of Afton, Bainbridge, Coventry, Greene, Guilford, Oxford and Smithville.

Lewis: Only the Township of Grieg, Lewis, Leyden, Lowville, Lyonsdale, Martinsburg, Turin, West Turin and Watson.

Madison: Only the Townships of Brookfield, Eaton, Hamilton, Lebanon, Lincoln, Madison, Smithfield, Stockbridge and the City of Oneida

Otsego: Entire county EXCEPT Townships of Butternuts, Laurens, Maryland, Milford, Morris, Oneonta, Otego, Unidilla and Worchester.

Warren: Only the Townships of Bolton, Warrensburg, Thurman, Stony Creek, Luzerne, Caldwell (Lake George), and Queensbury.

**WAGES**

**GROUP #1:**

Warehousemen, Yardmen, Truck Helpers, Pickups, Panel Trucks, Flatboy Material Trucks(straight jobs), Single Axel Dump Trucks, Dumpsters, Material Checkers and Receivers, Greasers, Truck Tiremen, Mechanics Helpers and Parts Chasers.

**GROUP #2:**

Tandems and Batch Trucks, Mechanics, Dispatcher.

**GROUP #3:**

Semi-Trailers, Low-boy Trucks, Asphalt Distributor Trucks, and Agitator, Mixer Trucks and dumpcrete type vehicles, Truck Mechanic, Fuel Trucks.

**GROUP #4:**

Specialized Earth Moving Equipment, Euclid type, or similar off-highway, where not self-loading, Straddle (Ross) Carrier, and self-contained concrete mobile truck.

**GROUP #5:**

Off-highway Tandem Back-Dump, Twin Engine Equipment and Double-Hitched Equipment where not self-loading.

WAGES per hour	07/01/2023	07/01/2024
Group #1	\$ 37.59	\$ 39.75
Group #2	37.65	39.81
Group #3	37.74	39.90
Group #4	37.87	40.03
Group #5	38.03	40.19

Hazardous waste projects that require a Level C or greater protection shall be paid an additional \$ 1.00 per hour.  
 All employees who work a single irregular work shift starting between 5pm and 1 am on governmental mandated night shifts shall be paid an additional \$1.50 per hour.  
 \*\*Note-For work bid on or after April 1, 1995, there shall be a 12 month carryover of the last posted rate in effect at the time of the bid.

NOTE - The "Employer Registration" (30.1) use of a '4 Day/10 Hour Work schedules' will no longer be accepted or processed. All registered projects prior to June 30, 2023 will expire within the granted time frame.

For Pre-Registered Projects Four (4), Ten (10) hour days may be worked at straight time during a week, Monday thru Thursday. Friday may be used as a make-up day. Tuesday thru Friday may be worked with no make-up day. For further clarification contact your local Bureau Office.

\*\* Will be removed on 07/01/2024

**SUPPLEMENTAL BENEFITS**

Per hour:

	\$ 28.13	\$28.97
	+\$1.00 per*	+\$1.00 per*
	hour worked	hour worked

(\*) not applicable to paid holidays

**OVERTIME PAY**

See (B, E, Q, X) on OVERTIME PAGE

**HOLIDAY**

Paid: See (5, 6) on HOLIDAY PAGE  
 Overtime: See (5, 6) on HOLIDAY PAGE

1-294h/h

**Welder**

**06/01/2024**

**JOB DESCRIPTION** Welder

**DISTRICT 1**

**ENTIRE COUNTIES**

Albany, Allegany, Bronx, Broome, Cattaraugus, Cayuga, Chautauqua, Chemung, Chenango, Clinton, Columbia, Cortland, Delaware, Dutchess, Erie, Essex, Franklin, Fulton, Genesee, Greene, Hamilton, Herkimer, Jefferson, Kings, Lewis, Livingston, Madison, Monroe, Montgomery, Nassau, New York, Niagara, Oneida, Onondaga, Ontario, Orange, Orleans, Oswego, Otsego, Putnam, Queens, Rensselaer, Richmond, Rockland, Saratoga, Schenectady, Schoharie, Schuylar, Seneca, St. Lawrence, Steuben, Suffolk, Sullivan, Tioga, Tompkins, Ulster, Warren, Washington, Wayne, Westchester, Wyoming, Yates

**WAGES**

Per hour 07/01/2023

Welder: To be paid the same rate of the mechanic performing the work.\*

\*EXCEPTION: If a specific welder certification is required, then the 'Certified Welder' rate in that trade tag will be paid.

**OVERTIME PAY**

**HOLIDAY**

1-As Per Trade

## Overtime Codes

Following is an explanation of the code(s) listed in the OVERTIME section of each classification contained in the attached schedule. Additional requirements may also be listed in the HOLIDAY section.

NOTE: Supplemental Benefits are 'Per hour worked' (for each hour worked) unless otherwise noted

- ( AA ) Time and one half of the hourly rate after 7 and one half hours per day
- ( A ) Time and one half of the hourly rate after 7 hours per day
- ( B ) Time and one half of the hourly rate after 8 hours per day
- ( B1 ) Time and one half of the hourly rate for the 9th & 10th hours week days and the 1st 8 hours on Saturday.  
Double the hourly rate for all additional hours
- ( B2 ) Time and one half of the hourly rate after 40 hours per week
- ( C ) Double the hourly rate after 7 hours per day
- ( C1 ) Double the hourly rate after 7 and one half hours per day
- ( D ) Double the hourly rate after 8 hours per day
- ( D1 ) Double the hourly rate after 9 hours per day
- ( E ) Time and one half of the hourly rate on Saturday
- ( E1 ) Time and one half 1st 4 hours on Saturday; Double the hourly rate all additional Saturday hours
- ( E2 ) Saturday may be used as a make-up day at straight time when a day is lost during that week due to inclement weather
- ( E3 ) Between November 1st and March 3rd Saturday may be used as a make-up day at straight time when a day is lost during that week due to inclement weather, provided a given employee has worked between 16 and 32 hours that week
- ( E4 ) Saturday and Sunday may be used as a make-up day at straight time when a day is lost during that week due to inclement weather
- ( E5 ) Double time after 8 hours on Saturdays
- ( F ) Time and one half of the hourly rate on Saturday and Sunday
- ( G ) Time and one half of the hourly rate on Saturday and Holidays
- ( H ) Time and one half of the hourly rate on Saturday, Sunday, and Holidays
- ( I ) Time and one half of the hourly rate on Sunday
- ( J ) Time and one half of the hourly rate on Sunday and Holidays
- ( K ) Time and one half of the hourly rate on Holidays
- ( L ) Double the hourly rate on Saturday
- ( M ) Double the hourly rate on Saturday and Sunday
- ( N ) Double the hourly rate on Saturday and Holidays
- ( O ) Double the hourly rate on Saturday, Sunday, and Holidays
- ( P ) Double the hourly rate on Sunday
- ( Q ) Double the hourly rate on Sunday and Holidays
- ( R ) Double the hourly rate on Holidays
- ( S ) Two and one half times the hourly rate for Holidays

- ( S1 ) Two and one half times the hourly rate the first 8 hours on Sunday or Holidays One and one half times the hourly rate all additional hours.
- ( T ) Triple the hourly rate for Holidays
- ( U ) Four times the hourly rate for Holidays
- ( V ) Including benefits at SAME PREMIUM as shown for overtime
- ( W ) Time and one half for benefits on all overtime hours.
- ( X ) Benefits payable on Paid Holiday at straight time. If worked, additional benefit amount will be required for worked hours. (Refer to other codes listed.)

## Holiday Codes

### PAID Holidays:

Paid Holidays are days for which an eligible employee receives a regular day's pay, but is not required to perform work. If an employee works on a day listed as a paid holiday, this remuneration is in addition to payment of the required prevailing rate for the work actually performed.

### OVERTIME Holiday Pay:

Overtime holiday pay is the premium pay that is required for work performed on specified holidays. It is only required where the employee actually performs work on such holidays. The applicable holidays are listed under HOLIDAYS: OVERTIME. The required rate of pay for these covered holidays can be found in the OVERTIME PAY section listings for each classification.

Following is an explanation of the code(s) listed in the HOLIDAY section of each classification contained in the attached schedule. The Holidays as listed below are to be paid at the wage rates at which the employee is normally classified.

- ( 1 ) None
- ( 2 ) Labor Day
- ( 3 ) Memorial Day and Labor Day
- ( 4 ) Memorial Day and July 4th
- ( 5 ) Memorial Day, July 4th, and Labor Day
- ( 6 ) New Year's, Thanksgiving, and Christmas
- ( 7 ) Lincoln's Birthday, Washington's Birthday, and Veterans Day
- ( 8 ) Good Friday
- ( 9 ) Lincoln's Birthday
- ( 10 ) Washington's Birthday
- ( 11 ) Columbus Day
- ( 12 ) Election Day
- ( 13 ) Presidential Election Day
- ( 14 ) 1/2 Day on Presidential Election Day
- ( 15 ) Veterans Day
- ( 16 ) Day after Thanksgiving
- ( 17 ) July 4th
- ( 18 ) 1/2 Day before Christmas
- ( 19 ) 1/2 Day before New Years
- ( 20 ) Thanksgiving
- ( 21 ) New Year's Day
- ( 22 ) Christmas
- ( 23 ) Day before Christmas
- ( 24 ) Day before New Year's
- ( 25 ) Presidents' Day
- ( 26 ) Martin Luther King, Jr. Day
- ( 27 ) Memorial Day
- ( 28 ) Easter Sunday

( 29 )      Juneteenth

**New York State Department of Labor - Bureau of Public Work  
State Office Building Campus  
Building 12 - Room 130  
Albany, New York 12226**

**REQUEST FOR WAGE AND SUPPLEMENT INFORMATION**

As Required by Articles 8 and 9 of the NYS Labor Law

Fax (518) 485-1870 or mail this form for new schedules or for determination for additional occupations.

**This Form Must Be Typed**

Submitted By:

(Check Only One)

Contracting Agency

Architect or Engineering Firm

Public Work District Office

Date:

**A. Public Work Contract to be let by:** (Enter Data Pertaining to Contracting/Public Agency)

1. Name and complete address  (Check if new or change)

Telephone

Fax

E-Mail:

2. NY State Units (see Item 5).

01 DOT

02 OGS

03 Dormitory Authority

04 State University  
Construction Fund

05 Mental Hygiene  
Facilities Corp.

06 OTHER N.Y. STATE UNIT

07 City

08 Local School District

09 Special Local District, i.e.,  
Fire, Sewer, Water District

10 Village

11 Town

12 County

13 Other Non-N.Y. State  
(Describe)

3. SEND REPLY TO  (check if new or change)  
Name and complete address:

Telephone

Fax

E-Mail:

4. SERVICE REQUIRED. Check appropriate box and provide project information.

New Schedule of Wages and Supplements.

APPROXIMATE BID DATE :

Additional Occupation and/or Redetermination

PRC NUMBER ISSUED PREVIOUSLY FOR  
THIS PROJECT :

OFFICE USE ONLY

**B. PROJECT PARTICULARS**

5. Project Title \_\_\_\_\_

Description of Work \_\_\_\_\_

Contract Identification Number \_\_\_\_\_

Note: For NYS units, the OSC Contract No. \_\_\_\_\_

6. Location of Project:

Location on Site \_\_\_\_\_

Route No/Street Address \_\_\_\_\_

Village or City \_\_\_\_\_

Town \_\_\_\_\_

County \_\_\_\_\_

7. Nature of Project - Check One:

1. New Building
2. Addition to Existing Structure
3. Heavy and Highway Construction (New and Repair)
4. New Sewer or Waterline
5. Other New Construction (Explain)
6. Other Reconstruction, Maintenance, Repair or Alteration
7. Demolition
8. Building Service Contract

8. OCCUPATION FOR PROJECT :

- Construction (Building, Heavy Highway/Sewer/Water)
- Tunnel
- Residential
- Landscape Maintenance
- Elevator maintenance
- Exterminators, Fumigators
- Fire Safety Director, NYC Only
- Fuel Delivery
- Guards, Watchmen
- Janitors, Porters, Cleaners, Elevator Operators
- Moving furniture and equipment
- Trash and refuse removal
- Window cleaners
- Other (Describe)

9. Does this project comply with the Wicks Law involving separate bidding? YES  NO

10. Name and Title of Requester

**Signature**







NEW YORK STATE DEPARTMENT OF LABOR  
Bureau of Public Work - Debarment List

**LIST OF EMPLOYERS INELIGIBLE TO BID ON OR BE  
AWARDED ANY PUBLIC WORK CONTRACT**

Under Article 8 and Article 9 of the NYS Labor Law, a contractor, sub-contractor and/or its successor shall be debarred and ineligible to submit a bid on or be awarded any public work or public building service contract/sub-contract with the state, any municipal corporation or public body for a period of five (5) years from the date of debarment when:

- Two (2) final determinations have been rendered within any consecutive six-year (6) period determining that such contractor, sub-contractor and/or its successor has WILLFULLY failed to pay the prevailing wage and/or supplements;
- One (1) final determination involves falsification of payroll records or the kickback of wages and/or supplements.

The agency issuing the determination and providing the information, is denoted under the heading 'Fiscal Officer'. DOL = New York State Department of Labor; NYC = New York City Comptroller's Office; AG = New York State Attorney General's Office; DA = County District Attorney's Office.

**Debarment Database:** To search for contractors, sub-contractors and/or their successors debarred from bidding or being awarded any public work contract or subcontract under NYS Labor Law Articles 8 and 9, or under NYS Workers' Compensation Law Section 141-b, access the database at this link: <https://apps.labor.ny.gov/EDList/searchPage.do>

**For inquiries where WCB is listed as the "Agency", please call 1-866-546-9322**



**NYS DOL Bureau of Public Work Debarment List 05/24/2024**

**Article 8**

AGENCY	Fiscal Officer	FEIN	EMPLOYER NAME	EMPLOYER DBA NAME	ADDRESS	DEBARMENT START DATE	DEBARMENT END DATE
DOL	DOL	****5754	0369 CONTRACTORS, LLC		515 WEST AVE UNIT PH 13NORWALK CT 06850	05/12/2021	05/12/2026
DOL	DOL	****5784	A.J.M. TRUCKING, INC.		PO BOX 2064 MONROE NY 10950	02/12/2024	02/12/2029
DOL	AG	****1812	ADVANCED BUILDERS & LAND DEVELOPMENT, INC.		400 OSER AVE #2300HAUPPAUGE NY 11788	09/11/2019	09/11/2024
DOL	DOL	****1687	ADVANCED SAFETY SPRINKLER INC		261 MILL ROAD P.O BOX 296EAST AURORA NY 14052	05/29/2019	05/29/2024
DOL	NYC		ALL COUNTY SEWER & DRAIN, INC.		7 GREENFIELD DR WARWICK NY 10990	03/25/2022	03/25/2027
DOL	NYC		AMJED PARVEZ		401 HANOVER AVENUE STATEN ISLAND NY 10304	01/11/2021	01/11/2026
DOL	DOL		ANGELO F COKER		2610 SOUTH SALINA STREET SUITE 14SYRACUSE NY 13205	09/17/2020	09/17/2025
DOL	DOL		ANGELO GARCIA		515 WEST AVE UNIT PH 13NORWALK CT 06850	05/12/2021	05/12/2026
DOL	DOL		ANGELO TONDO		449 WEST MOMBSHA ROAD MONROE NY 10950	06/06/2022	06/06/2027
DOL	DOL	****4231	ANKER'S ELECTRIC SERVICE, INC.		10 SOUTH 5TH ST LOCUST VALLEY NY 11560	09/26/2022	09/26/2027
DOL	DOL		ANTHONY MONGELLI		PO BOX 2064 MONROE NY 10950	02/12/2024	02/12/2029
DOL	NYC		ARADCO CONSTRUCTION CORP		115-46 132RD ST SOUTH OZONE PARK NY 11420	09/17/2020	09/17/2025
DOL	DOL		ARNOLD A. PAOLINI		1250 BROADWAY ST BUFFALO NY 14212	02/03/2020	02/03/2025
DOL	NYC		ARSHAD MEHMOOD		168-42 88TH AVENUE JAMAICA NY 11432	11/20/2019	11/20/2024
DOL	NYC		AVM CONSTRUCTION CORP		117-72 123RD ST SOUTH OZONE PARK NY 11420	09/17/2020	09/17/2025
DOL	NYC		AZIDABEGUM		524 MCDONALD AVENUE BROOKLYN NY 11218	09/17/2020	09/17/2025
DOL	DOL	****8421	B & B DRYWALL, INC		206 WARREN AVE APT 1WHITE PLAINS NY 10603	12/14/2021	12/14/2026
DOL	DOL		B&L RENOVATION CO.		618 OCEAN PARKWAY APT A6BROOKLYN NY 11230	09/17/2020	09/17/2025
DOL	DOL		BERNARD BEGLEY		38 LONG RIDGE ROAD BEDFORD NY 10506	12/18/2019	12/18/2024
DOL	NYC	****2113	BHW CONTRACTING, INC.		401 HANOVER AVENUE STATEN ISLAND NY 10304	01/11/2021	01/11/2026
DOL	DOL	****3627	BJB CONSTRUCTION CORP.		38 LONG RIDGE ROAD BEDFORD NY 10506	12/18/2019	12/18/2024
DOL	DOL	****5078	BLACK RIVER TREE REMOVAL, LLC		29807 ANDREWS ROAD BLACK RIVER NY 13032	10/17/2023	10/17/2028
DOL	DOL	****4512	BOB BRUNO EXCAVATING, INC		5 MORNINGSIDE DR AUBURN NY 13021	05/28/2019	05/28/2024
DOL	DOL		BRADLEY J SCHUKA		4 BROTHERS ROAD WAPPINGERS FALLS NY 12590	10/20/2020	10/20/2025
DOL	DOL	****9383	C.C. PAVING AND EXCAVATING, INC.		2610 SOUTH SALINA ST SUITE 12SYRACUSE NY 13205	09/17/2020	09/17/2025
DOL	DOL	****4083	C.P.D. ENTERPRISES, INC		P.O BOX 281 WALDEN NY 12586	03/03/2020	03/03/2025
DOL	DOL	****5161	CALADRI DEVELOPMENT CORP.		1223 PARK ST. PEEKSKILL NY 10566	05/17/2021	05/17/2026
DOL	DOL	****3391	CALI ENTERPRISES, INC.		1223 PARK STREET PEEKSKILL NY 10566	05/17/2021	05/17/2026
DOL	NYC		CALVIN WALTERS		465 EAST THIRD ST MT. VERNON NY 10550	09/09/2019	09/09/2024
DOL	DOL	****4155	CASA BUILDERS, INC.	FRIEDLANDER CONSTRUCTION	64 N PUTT CONNERS ROAD NEW PALTZ NY 12561	05/10/2023	05/10/2028
DOL	AG	****7247	CENTURY CONCRETE CORP		2375 RAYNOR ST RONKONKOMA NY 11779	08/04/2021	08/04/2026
DOL	DOL	****0026	CHANTICLEER CONSTRUCTION LLC		4 BROTHERS ROAD WAPPINGERS FALLS NY 12590	10/20/2020	10/20/2025
DOL	NYC	****2117	CHARAN ELECTRICAL ENTERPRISES		9-11 40TH AVENUE LONG ISLAND CITY NY 11101	09/26/2023	09/26/2028
DOL	NYC		CHARLES ZAHRADKA		863 WASHINGTON STREET FRANKLIN SQUARE NY 11010	03/10/2020	03/10/2025

**NYS DOL Bureau of Public Work Debarment List 05/24/2024**

**Article 8**

DOL	DOL		CHRISTOPHER GRECO		26 NORTH MYRTLE AVENUE SPRING VALLEY NY 10956	02/18/2021	02/18/2026
DOL	DOL		CHRISTOPHER PAPASTEFANOU A/K/A CHRIS PAPASTEFANOU		1445 COMMERCE AVE BRONX NY 10461	05/30/2019	05/30/2024
DOL	DOL		CRAIG JOHANSEN		10 SOUTH 5TH ST LOCUST VALLEY NY 11560	09/26/2022	09/26/2027
DOL	DOL	****3228	CROSS-COUNTY LANDSCAPING AND TREE SERVICE, INC.	ROCKLAND TREE SERVICE	26 NORTH MYRTLE AVENUE SPRING VALLEY NY 10956	02/18/2021	02/18/2026
DOL	DOL	****7619	DANCO CONSTRUCTION UNLIMITED INC.		485 RAFT AVENUE HOLBROOK NY 11741	10/19/2021	10/19/2026
DOL	DOL		DANIEL ROBERT MCNALLY		7 GREENFIELD DRIVE WARWICK NY 10990	03/25/2022	03/25/2027
DOL	DOL		DARIAN L COKER		2610 SOUTH SALINA ST SUITE 2CSYRACUSE NY 13205	09/17/2020	09/17/2025
DOL	DOL		DAVID FRIEDLANDER		64 NORTH PUTT CORNERS RD NEW PALTZ NY 12561	05/10/2023	05/10/2028
DOL	NYC		DAVID WEINER		14 NEW DROP LANE 2ND FLOORSTATEN ISLAND NY 10306	11/14/2019	11/14/2024
DOL	DOL		DELPHI PAINTING & DECORATING CO INC		1445 COMMERCE AVE BRONX NY 10461	05/30/2019	05/30/2024
DOL	DOL		DINA TAYLOR		64 N PUTT CONNERS RD NEW PALTZ NY 12561	05/10/2023	05/10/2028
DOL	DOL	****5175	EAGLE MECHANICAL AND GENERAL CONSTRUCTION LLC		11371 RIDGE RD WOLCOTT NY 14590	02/03/2020	02/03/2025
DOL	AG		EDWIN HUTZLER		23 NORTH HOWELLS RD BELLPORT NY 11713	08/04/2021	08/04/2026
DOL	DA		EDWIN HUTZLER		2375 RAYNOR STREET RONKONKOMA NY 11779	08/04/2021	08/04/2026
DOL	DOL	****0780	EMES HEATING & PLUMBING CONTR		5 EMES LANE MONSEY NY 10952	01/20/2002	01/20/3002
DOL	DOL		EUGENIUSZ "GINO" KUCHAR		195 KINGSLAND AVE BROOKLYN NY 11222	12/22/2023	12/22/2028
DOL	DA		FREDERICK HUTZLER		2375 RAYNOR STREET RONKONKOMA NY 11779	08/04/2021	08/04/2026
DOL	NYC	****6616	G & G MECHANICAL ENTERPRISES, LLC.		1936 HEMPSTEAD TURNPIKE EAST MEDOW NY 11554	11/29/2019	11/29/2024
DOL	DOL	****2998	G.E.M. AMERICAN CONSTRUCTION CORP.		195 KINGSLAND AVE BROOKLYN NY 11222	12/22/2023	12/22/2028
DOL	NYC		GAYATRI MANGRU		21 DAREWOOD LANE VALLEY STREAM NY 11581	09/17/2020	09/17/2025
DOL	DA		GEORGE LUCEY		150 KINGS STREET BROOKLYN NY 11231	01/19/1998	01/19/2998
DOL	DOL		GIGI SCHNECKENBURGER		261 MILL RD EAST AURORA NY 14052	05/29/2019	05/29/2024
DOL	DA		GIOVANNA TRAVALJA		3735 9TH ST LONG ISLAND CITY NY 11101	01/05/2023	01/05/2028
DOL	DA	****0213	GORILLA CONTRACTING GROUP, LLC		505 MANHATTAN AVE WEST BABYLON NY 11704	10/05/2023	10/05/2028
DOL	DOL		HANS RATH		24 ELDOR AVENUE NEW CITY NY 10956	02/03/2020	02/03/2025
DOL	DOL		HERBERT CLEMEN		42 FOWLER AVENUE CORTLAND MANOR NY 10567	01/24/2023	01/24/2028
DOL	DOL		HERBERT CLEMEN		42 FOWLER AVENUE CORTLAND MANOR NY 10567	10/25/2022	10/25/2027
DOL	DOL		IRENE KASELIS		32 PENNINGTON AVE WALDWICK NJ 07463	05/30/2019	05/30/2024
DOL	DOL	****9211	J. WASE CONSTRUCTION CORP.		8545 RT 9W ATHENS NY 12015	03/09/2021	03/09/2026
DOL	DOL		J.M.J CONSTRUCTION		151 OSTRANDER AVENUE SYRACUSE NY 13205	11/21/2022	11/21/2027
DOL	DOL		J.R. NELSON CONSTRUCTION		531 THIRD STREET ALBANY NY 12206	11/07/2023	11/07/2028
DOL	DOL		J.R. NELSON CONSTRUCTION		531 THIRD STREET ALBANY NY 12206	12/22/2022	12/22/2027
DOL	DOL		J.R. NELSON CONSTRUCTION		531 THIRD STREET ALBANY NY 12206	10/25/2022	10/25/2027
DOL	DOL		J.R. NELSON, LLC		531 THIRD STREET ALBANY NY 12206	12/22/2022	12/22/2027
DOL	DOL		J.R. NELSON, LLC		531 THIRD STREET ALBANY NY 12206	11/07/2023	11/07/2028

**NYS DOL Bureau of Public Work Debarment List 05/24/2024**

**Article 8**

DOL	DOL		J.R. NELSON, LLC		531 THIRD STREET ALBANY NY 12206	10/25/2022	10/25/2027
DOL	DOL		J.R.N COMPANIES, LLC		531 THIRD STREET ALBANY NY 12206	12/12/2022	12/12/2027
DOL	DOL		J.R.N COMPANIES, LLC		531 THIRD STREET ALBANY NY 12206	11/07/2023	11/07/2028
DOL	DOL		J.R.N COMPANIES, LLC		531 THIRD STREET ALBANY NY 12206	10/25/2022	10/25/2027
DOL	DOL	*****1147	J.R.N. CONSTRUCTION, LLC		531 THIRD ST ALBANY NY 12206	11/07/2023	11/07/2028
DOL	DOL	*****1147	J.R.N. CONSTRUCTION, LLC		531 THIRD ST ALBANY NY 12206	12/22/2022	12/22/2027
DOL	DOL	*****1147	J.R.N. CONSTRUCTION, LLC		531 THIRD ST ALBANY NY 12206	10/25/2022	10/25/2027
DOL	DOL		JAMES J. BAKER		7901 GEE ROAD CANASTOTA NY 13032	08/17/2021	08/17/2026
DOL	DOL		JASON P. RACE		3469 STATE RT. 69 PERISH NY 13131	09/29/2021	09/29/2026
DOL	DOL		JASON P. RACE		3469 STATE RT. 69 PERISH NY 13131	02/09/2022	02/09/2027
DOL	DOL		JASON P. RACE		3469 STATE RT. 69 PERISH NY 13131	11/15/2022	11/15/2027
DOL	DOL		JASON P. RACE		3469 STATE RT. 69 PERISH NY 13131	03/01/2022	03/01/2027
DOL	DOL	*****7993	JBS DIRT, INC.		7901 GEE ROAD CANASTOTA NY 13032	08/17/2021	08/17/2026
DOL	DOL	*****2435	JEFFEL D. JOHNSON	JMJ7 AND SON	5553 CAIRNSTRAIL CLAY NY 13041	11/21/2022	11/21/2027
DOL	DOL		JEFFEL JOHNSON ELITE CARPENTER REMODEL AND CONSTRUCTION		C2 EVERGREEN CIRCLE LIVERPOOL NY 13090	11/21/2022	11/21/2027
DOL	DOL	*****2435	JEFFREY M. JOHNSON	JMJ7 AND SON	5553 CAIRNS TRAIL CLAY NY 13041	11/21/2022	11/21/2027
DOL	NYC		JENNIFER GUERRERO		1936 HEMPSTEAD TURNPIKE EAST MEADOW NY 11554	11/29/2019	11/29/2024
DOL	DOL		JIM PLAUGHER		17613 SANTE FE LINE ROAD WAYNEFIELD OH 45896	07/16/2021	07/16/2026
DOL	DOL		JMJ7 & SON CONSTRUCTION, LLC		5553 CAIRNS TRAIL LIVERPOOL NY 13041	11/21/2022	11/21/2027
DOL	DOL		JMJ7 AND SONS CONTRACTORS		5553 CAIRNS TRAIL CLAY NY 13041	11/21/2022	11/21/2027
DOL	DOL		JMJ7 CONTRACTORS		7014 13TH AVENUE BROOKLYN NY 11228	11/21/2022	11/21/2027
DOL	DOL		JMJ7 CONTRACTORS AND SONS		5553 CAIRNS TRAIL CLAY NY 13041	11/21/2022	11/21/2027
DOL	DOL		JMJ7 CONTRACTORS, LLC		5553 CAIRNS TRAIL CLAY NY 13041	11/21/2022	11/21/2027
DOL	DOL		JOHN GOCEK		14B COMMERCIAL AVE ALBANY NY 12065	11/14/2019	11/14/2024
DOL	DOL		JOHN MARKOVIC		47 MANDON TERRACE HAWTHORN NJ 07506	03/29/2021	03/29/2026
DOL	DOL		JOHN WASE		8545 RT 9W ATHENS NY 12015	03/09/2021	03/09/2026
DOL	DOL		JON E DEYOUNG		261 MILL RD P.O BOX 296EAST AURORA NY 14052	05/29/2019	05/29/2024
DOL	DOL		JORGE RAMOS		8970 MIKE GARCIA DR MANASSAS VA 20109	07/16/2021	07/16/2026
DOL	DOL		JOSEPH K. SALERNO		1010 TILDEN AVE UTICA NY 13501	07/24/2023	07/24/2028
DOL	DOL		JOSEPH K. SALERNO II		1010 TILDEN AVE UTICA NY 13501	07/24/2023	07/24/2028
DOL	DOL	*****5116	JP RACE PAINTING, INC. T/A RACE PAINTING		3469 STATE RT. 69 PERISH NY 13131	02/09/2022	02/09/2027
DOL	DOL	*****5116	JP RACE PAINTING, INC. T/A RACE PAINTING		3469 STATE RT. 69 PERISH NY 13131	11/15/2022	11/15/2027
DOL	DOL	*****5116	JP RACE PAINTING, INC. T/A RACE PAINTING		3469 STATE RT. 69 PERISH NY 13131	09/29/2021	09/29/2026
DOL	DOL	*****5116	JP RACE PAINTING, INC. T/A RACE PAINTING		3469 STATE RT. 69 PERISH NY 13131	03/01/2022	03/01/2027
DOL	DOL	*****5116	JP RACE PAINTING, INC. T/A RACE PAINTING		3469 STATE RT. 69 PERISH NY 13131	03/01/2022	03/01/2027
DOL	DOL		JRN CONSTRUCTION CO, LLC		1024 BROADWAY ALBANY NY 12204	11/07/2023	11/07/2028

**NYS DOL Bureau of Public Work Debarment List 05/24/2024**

**Article 8**

DOL	DOL	*****1147	JRN CONSTRUCTION, LLC		531 THIRD STREET ALBANY NY 12206	10/25/2022	10/25/2027
DOL	DOL	*****1147	JRN CONSTRUCTION, LLC		531 THIRD STREET ALBANY NY 12206	12/22/2022	12/22/2027
DOL	DOL	*****1147	JRN CONSTRUCTION, LLC		531 THIRD STREET ALBANY NY 12206	11/07/2023	11/07/2028
DOL	DOL		JRN PAVING, LLC		531 THIRD STREET ALBANY NY 12206	10/25/2022	10/25/2027
DOL	DOL		JRN PAVING, LLC		531 THIRD STREET ALBANY NY 12206	12/22/2022	12/22/2027
DOL	DOL		JRN PAVING, LLC		531 THIRD STREET ALBANY NY 12206	11/07/2023	11/07/2028
DOL	DOL		JULIUS AND GITA BEHREND		5 EMES LANE MONSEY NY 10952	11/20/2002	11/20/3002
DOL	DOL		KARIN MANGIN		796 PHELPS ROAD FRANKLIN LAKES NJ 07417	12/01/2020	12/01/2025
DOL	DOL		KATE E. CONNOR		7088 INTERSTATE ISLAND RD SYRACUSE NY 13209	03/31/2021	03/31/2026
DOL	DOL		KEAN INDUSTRIES, LLC		2345 RT. 52 SUITE 2NHOPEWELL JUNCTION NY 12533	12/18/2023	12/18/2028
DOL	DOL	*****2959	KELC DEVELOPMENT, INC		7088 INTERSTATE ISLAND RD SYRACUSE NY 13209	03/31/2021	03/31/2026
DOL	DOL		KIMBERLY F. BAKER		7901 GEE ROAD CANASTOTA NY 13032	08/17/2021	08/17/2026
DOL	DOL		KMA GROUP II, INC.		29-10 38TH AVENUE LONG ISLAND CITY NY 11101	10/11/2023	10/11/2028
DOL	DOL	*****1833	KMA GROUP INC.		29-10 38TH AVENUE LONG ISLAND CITY NY 11101	10/11/2023	10/11/2028
DOL	DOL		KMA INSULATION, INC.		29-10 38TH AVENUE LONG ISLAND CITY NY 11101	10/11/2023	10/11/2028
DOL	DOL		KRIN HEINEMANN		2345 ROUTE 52, SUITE 2N HOPEWELL JUNCTION NY 12533	12/18/2023	12/18/2028
DOL	NYC		KULWANT S. DEOL		9-11 40TH AVENUE LONG ISLAND CITY NY 11101	09/26/2023	09/26/2028
DOL	DA	*****8816	LAKE CONSTRUCTION AND DEVELOPMENT CORPORATION		150 KINGS STREET BROOKLYN NY 11231	08/19/1998	08/19/2998
DOL	DOL		LEROY E. NELSON JR		531 THIRD ST ALBANY NY 12206	10/25/2022	10/25/2027
DOL	DOL		LEROY E. NELSON JR		531 THIRD ST ALBANY NY 12206	12/22/2022	12/22/2027
DOL	DOL		LEROY E. NELSON JR		531 THIRD ST ALBANY NY 12206	11/07/2023	11/07/2028
DOL	AG	*****3291	LINTECH ELECTRIC, INC.		3006 TILDEN AVE BROOKLYN NY 11226	02/16/2022	02/16/2027
DOL	DOL		LOUIS A. CALICCHIA		1223 PARK ST. PEEKSKILL NY 10566	05/17/2021	05/17/2026
DOL	NYC		LUBOMIR PETER SVOBODA		27 HOUSMAN AVE STATEN ISLAND NY 10303	12/26/2019	12/26/2024
DOL	NYC		M & L STEEL & ORNAMENTAL IRON CORP.		27 HOUSMAN AVE STATEN ISLAND NY 10303	12/26/2019	12/26/2024
DOL	DOL	*****2196	MAINSTREAM SPECIALTIES, INC.		11 OLD TOWN RD SELKIRK NY 12158	02/02/2021	02/02/2026
DOL	DA		MANUEL P TOBIO		150 KINGS STREET BROOKLYN NY 14444	08/19/1998	08/19/2998
DOL	DA		MANUEL TOBIO		150 KINGS STREET BROOKLYN NY 11231	08/19/1998	08/19/2998
DOL	DOL		MAQSOOD AHMAD		618 OCEAN PKWY BROOKLYN NY 11230	09/17/2020	09/17/2025
DOL	NYC		MARIA NUBILE		84-22 GRAND AVENUE ELMHURST NY 11373	03/10/2020	03/10/2025
DOL	NYC	*****9926	MILLENNIUM FIRE PROTECTION, LLC		325 W. 38TH STREET SUITE 204NEW YORK NY 10018	11/14/2019	11/14/2024
DOL	NYC	*****0627	MILLENNIUM FIRE SERVICES, LLC		14 NEW DROP LNE 2ND FLOORSTATEN ISLAND NY 10306	11/14/2019	11/14/2024
DOL	DOL	*****1320	MJC MASON CONTRACTING, INC.		42 FOWLER AVENUE CORTLAND MANOR NY 10567	10/25/2022	10/25/2027
DOL	DOL	*****1320	MJC MASON CONTRACTING, INC.		42 FOWLER AVENUE CORTLAND MANOR NY 10567	01/24/2023	01/24/2028
DOL	NYC		MUHAMMED A. HASHEM		524 MCDONALD AVENUE BROOKLYN NY 11218	09/17/2020	09/17/2025

**NYSDOL Bureau of Public Work Debarment List 05/24/2024**

**Article 8**

DOL	NYC		NAMOW, INC.		84-22 GRAND AVENUE ELMHURST NY 11373	03/10/2020	03/10/2025
DOL	DOL	****7790	NATIONAL BUILDING & RESTORATION CORP		1010 TILDEN AVE UTICA NY 13501	07/24/2023	07/24/2028
DOL	DOL	****1797	NATIONAL CONSTRUCTION SERVICES, INC		1010 TILDEN AVE UTICA NY 13501	07/24/2023	07/24/2028
DOL	NYC		NAVIT SINGH		402 JERICHO TURNPIKE NEW HYDE PARK NY 11040	08/10/2022	08/10/2027
DOL	DOL		NELCO CONTRACTING, LLC		1024 BROADWAY ALBANY NY 12204	11/07/2023	11/07/2028
DOL	DA		NICHOLAS T. ANALITIS		505 MANHATTAN AVE WEST BABYLON NY 11704	10/05/2023	10/05/2028
DOL	DOL		NICHOLE E. FRASER A/K/A NICHOLE RACE		3469 STATE RT. 69 PERISH NY 13131	03/01/2022	03/01/2027
DOL	DOL		NICHOLE E. FRASER A/K/A NICHOLE RACE		3469 STATE RT. 69 PERISH NY 13131	11/15/2022	11/15/2027
DOL	DOL		NICHOLE E. FRASER A/K/A NICHOLE RACE		3469 STATE RT. 69 PERISH NY 13131	09/29/2021	09/29/2026
DOL	DOL		NICHOLE E. FRASER A/K/A NICHOLE RACE		3469 STATE RT. 69 PERISH NY 13131	02/09/2022	02/09/2027
DOL	DOL	****7429	NICOLAE I. BARBIR	BESTUCCO CONSTRUCTI ON, INC.	444 SCHANTZ ROAD ALLEN TOWN PA 18104	09/17/2020	09/17/2025
DOL	NYC	****5643	NYC LINE CONTRACTORS, INC.		402 JERICHO TURNPIKE NEW HYDE PARK NY 11040	08/10/2022	08/10/2027
DOL	DOL		PATRICK PENNACCHIO		2345 RT. 52 SUITE 2NHOPEWELL JUNCTION NY 12533	12/18/2023	12/18/2028
DOL	DOL		PATRICK PENNACCHIO		2345 RT. 52 SUITE 2NHOPEWELL JUNCTION NY 12533	12/18/2023	12/18/2028
DOL	DOL		PAULINE CHAHALES		935 S LAKE BLVD MAHOPAC NY 10541	03/02/2021	03/02/2026
DOL	DOL		PETER STEVENS		11 OLD TOWN ROAD SELKIRK NY 12158	02/02/2021	02/02/2026
DOL	DOL		PETER STEVENS		8269 21ST ST BELLEROSE NY 11426	12/22/2022	12/22/2027
DOL	DOL	****0466	PRECISION BUILT FENCES, INC.		1617 MAIN ST PEEKSKILL NY 10566	03/03/2020	03/03/2025
DOL	NYC		RASHEL CONSTRUCTION CORP		524 MCDONALD AVENUE BROOKLYN NY 11218	09/17/2020	09/17/2025
DOL	DOL	****1068	RATH MECHANICAL CONTRACTORS, INC.		24 ELDOR AVENUE NEW CITY NY 10956	02/03/2020	02/03/2025
DOL	DOL	****2633	RAW POWER ELECTRIC CORP.		3 PARK CIRCLE MIDDLETOWN NY 10940	07/11/2022	07/11/2027
DOL	DA	****7559	REGAL CONTRACTING INC.		24 WOODBINE AVE NORTHPORT NY 11768	10/01/2020	10/01/2025
DOL	DOL		RICHARD REGGIO		1617 MAIN ST PEEKSKILL NY 10566	03/03/2020	03/03/2025
DOL	DOL		ROBBYE BISSE SAR		89-51 SPRINGFIELD BLVD QUEENS VILLAGE NY 11427	01/11/2003	01/11/3003
DOL	DOL		ROBERT A. VALERINO		3841 LANYARD COURT NEW PORT RICHEY FL 34652	07/09/2019	07/09/2024
DOL	DOL		ROBERT BRUNO		5 MORNINGSIDE DRIVE AUBURN NY 13021	05/28/2019	05/28/2024
DOL	DOL		ROMEO WARREN		161 ROBYN RD MONROE NY 10950	07/11/2022	07/11/2027
DOL	DOL		RONALD MESSEN		14B COMMERCIAL AVE ALBANY NY 12065	11/14/2019	11/14/2024
DOL	DOL	****7172	RZ & AL INC.		198 RIDGE AVENUE VALLEY STREAM NY 11581	06/06/2022	06/06/2027
DOL	DOL		SAL FRESINA MASONRY CONTRACTORS, INC.		1935 TEALL AVENUE SYRACUSE NY 13206	07/16/2021	07/16/2026
DOL	DOL		SAL MASONRY CONTRACTORS, INC.		(SEE COMMENTS) SYRACUSE NY 13202	07/16/2021	07/16/2026
DOL	DOL	****9874	SALFREE ENTERPRISES INC		P.O BOX 14 2821 GARDNER RD POMPEI NY 13138	07/16/2021	07/16/2026
DOL	DOL		SALVATORE A FRESINA A/K/A SAM FRESINA		107 FACTORY AVE P.O BOX 11070 SYRACUSE NY 13218	07/16/2021	07/16/2026
DOL	DOL		SAM FRESINA		107 FACTORY AVE P.O BOX 11070 SYRACUSE NY 13218	07/16/2021	07/16/2026
DOL	NYC	****0349	SAM WATERPROOFING INC		168-42 88TH AVENUE APT.1 AJAMAICA NY 11432	11/20/2019	11/20/2024



**NYS DOL Bureau of Public Work Debarment List 05/24/2024**

**Article 8**

DOL	DA	****0476	SAMCO ELECTRIC CORP.		3735 9TH ST LONG ISLAND CITY NY 11101	01/05/2023	01/05/2028
DOL	NYC	****1130	SCANA CONSTRUCTION CORP.		863 WASHINGTON STREET FRANKLIN SQUARE NY 11010	03/10/2020	03/10/2025
DOL	DOL	****2045	SCOTT DUFFIE	DUFFIE'S ELECTRIC, INC.	P.O BOX 111 CORNWALL NY 12518	03/03/2020	03/03/2025
DOL	DOL		SCOTT DUFFIE		P.O BOX 111 CORNWALL NY 12518	03/03/2020	03/03/2025
DOL	DA		SILVANO TRAVALJA		3735 9TH ST LONG ISLAND CITY NY 11101	01/05/2023	01/05/2028
DOL	DOL	****0440	SOLAR GUYS INC.		8970 MIKE GARCIA DR MANASSAS VA 20109	07/16/2021	07/16/2026
DOL	NYC		SOMATIE RAMSUNAHAI		115-46 132ND ST SOUTH OZONE PARK NY 11420	09/17/2020	09/17/2025
DOL	DOL	****2221	SOUTH BUFFALO ELECTRIC, INC.		1250 BROADWAY ST BUFFALO NY 14212	02/03/2020	02/03/2025
DOL	NYC	****3661	SPANIER BUILDING MAINTENANCE CORP		200 OAK DRIVE SYOSSET NY 11791	03/14/2022	03/14/2027
DOL	DOL		STANADOS KALOGELAS		485 RAFT AVENUE HOLBROOK NY 11741	10/19/2021	10/19/2026
DOL	DOL	****3496	STAR INTERNATIONAL INC		89-51 SPRINGFIELD BLVD QUEENS VILLAGE NY 11427	08/11/2003	08/11/3003
DOL	DOL	****6844	STEAM PLANT AND CHX SYSTEMS INC.		14B COMMERCIAL AVENUE ALBANY NY 12065	11/14/2019	11/14/2024
DOL	DOL	****9933	STEED GENERAL CONTRACTORS, INC.		1445 COMMERCE AVE BRONX NY 10461	05/30/2019	05/30/2024
DOL	DOL	****9528	STEEL-IT, LLC.		17613 SANTE FE LINE ROAD WAYNESFIELD OH 45896	07/16/2021	07/16/2026
DOL	DOL		STEFANOS PAPASTEFANOU, JR. A/K/A STEVE PAPASTEFANOU, JR.		256 WEST SADDLE RIVER RD UPPER SADDLE RIVER NJ 07458	05/30/2019	05/30/2024
DOL	DOL	****3800	SUBURBAN RESTORATION CO. INC.		5-10 BANTA PLACE FAIR LAWN PLACE NJ 07410	03/29/2021	03/29/2026
DOL	DOL	****9150	SURGE INC.		8269 21ST STREET BELLEROSE NY 11426	12/22/2022	12/22/2027
DOL	DOL		SYED RAZA		198 RIDGE AVENUE NY 11581	06/06/2022	06/06/2027
DOL	DOL		TERRY THOMPSON		11371 RIDGE RD WOLCOTT NY 14590	02/03/2020	02/03/2025
DOL	DOL	****9733	TERSAL CONSTRUCTION SERVICES INC		107 FACTORY AVE P.O BOX 11070SYRACUSE NY 13208	07/16/2021	07/16/2026
DOL	DOL		TERSAL CONTRACTORS, INC.		221 GARDNER RD P.O BOX 14POMPEI NY 13138	07/16/2021	07/16/2026
DOL	DOL		TERSAL DEVELOPMENT CORP.		1935 TEALL AVENUE SYRACUSE NY 13206	07/16/2021	07/16/2026
DOL	DOL	****5766	THE COKER CORPORATION	COKER CORPORATION	2610 SOUTH SALINA ST SUITE 14SYRACUSE NY 13205	09/17/2020	09/17/2025
DOL	DOL		TIMOTHY PERCY		29807 ANDREWS ROAD BLACK RIVER NY 13612	10/17/2023	10/17/2028
DOL	DA	****1050	TRI STATE CONSTRUCTION OF NY CORP.		50-39 175TH PLACE FRESH MEADOWS NY 11365	03/28/2022	03/28/2027
DOL	DA	****4106	TRIPLE H CONCRETE CORP		2375 RAYNOR STREET RONKONKOMA NY 11779	08/04/2021	08/04/2026
DOL	DOL	****8210	UPSTATE CONCRETE & MASONRY CONTRACTING CO INC		449 WEST MOMBASHA ROAD MONROE NY 10950	06/06/2022	06/06/2027
DOL	DOL	****6418	VALHALLA CONSTRUCTION, LLC.		796 PHLEPS ROAD FRANKLIN LAKES NJ 07417	12/01/2020	12/01/2025
DOL	NYC	****2426	VICKRAM MANGRU	VICK CONSTRUCTION	21 DAREWOOD LANE VALLEY STREAM NY 11581	09/17/2020	09/17/2025
DOL	NYC		VICKRAM MANGRU		21 DAREWOOD LANE VALLEY STREAM NY 11581	09/17/2020	09/17/2025
DOL	DOL		VIKTORIA RATH		24 ELDOR AVENUE NEW CITY NY 10956	02/03/2020	02/03/2025
DOL	NYC	****3673	WALTERS AND WALTERS, INC.		465 EAST AND THIRD ST MT. VERNON NY 10550	09/09/2019	09/09/2024
DOL	DOL	****3296	WESTERN NEW YORK CONTRACTORS, INC.		3841 LAYNARD COURT NEW PORT RICHEY FL 34652	07/09/2019	07/09/2024
DOL	DOL	****8266	WILLIAM CHRIS MCCLENDON	MCCLENDON ASPHALT PAVING	1646 FALLS STREET NIAGARA FALLS NY 14303	05/01/2023	05/01/2028

**NYS DOL Bureau of Public Work Debarment List 05/24/2024**

**Article 8**

DOL	DOL		WILLIAM CHRIS MCCLENDON		1646 FALLS STREET NIAGARA FALLS NY 14303	05/01/2023	05/01/2028
DOL	DOL		WILLIAM G. PROERFRIEDT		85 SPRUCEWOOD ROAD WEST BABYLON NY 11704	01/19/2021	01/19/2026
DOL	DOL	****5924	WILLIAM G. PROPHY, LLC	WGP CONTRACTIN G, INC.	54 PENTAQUIT AVE BAYSHORE NY 11706	01/19/2021	01/19/2026
DOL	DOL		XENOFON EFTHIMIADIS		29-10 38TH AVENUE LONG ISLAND CITY NY 11101	10/11/2023	10/11/2028

"General Decision Number: NY20240014 03/08/2024

Superseded General Decision Number: NY20230014

State: New York

Construction Types: Heavy and Highway  
HEAVY & HIGHWAY CONSTRUCTION

County: Oneida County in New York.

HEAVY AND HIGHWAY CONSTRUCTION PROJECTS

Note: Contracts subject to the Davis-Bacon Act are generally required to pay at least the applicable minimum wage rate required under Executive Order 14026 or Executive Order 13658. Please note that these Executive Orders apply to covered contracts entered into by the federal government that are subject to the Davis-Bacon Act itself, but do not apply to contracts subject only to the Davis-Bacon Related Acts, including those set forth at 29 CFR 5.1(a)(1).

If the contract is entered into on or after January 30, 2022, or the contract is renewed or extended (e.g., an option is exercised) on or after January 30, 2022:	<ul style="list-style-type: none"><li>. Executive Order 14026 generally applies to the contract.</li><li>. The contractor must pay all covered workers at least \$17.20 per hour (or the applicable wage rate listed on this wage determination, if it is higher) for all hours spent performing on the contract in 2024.</li></ul>
If the contract was awarded on or between January 1, 2015 and January 29, 2022, and the contract is not renewed or extended on or after January 30, 2022:	<ul style="list-style-type: none"><li>. Executive Order 13658 generally applies to the contract.</li><li>. The contractor must pay all covered workers at least \$12.90 per hour (or the applicable wage rate listed on this wage determination, if it is higher) for all hours spent performing on that contract in 2024.</li></ul>

The applicable Executive Order minimum wage rate will be

adjusted annually. If this contract is covered by one of the Executive Orders and a classification considered necessary for performance of work on the contract does not appear on this wage determination, the contractor must still submit a conformance request.

Additional information on contractor requirements and worker protections under the Executive Orders is available at <http://www.dol.gov/whd/govcontracts>.

Modification Number	Publication Date
0	01/05/2024
1	03/08/2024

BRNY0002-009 06/01/2018

UTICA CHAPTER

	Rates	Fringes
CEMENT MASON/CONCRETE FINISHER...	\$ 37.23	19.51+a

FOOTNOTE:

- a. Paid Holidays: Memorial Day, July the 4th, Labor Day, and Thanksgiving Day (provided the employee is employed one (1) day before and one (1) day after the holiday).

-----  
 CARP0277-001 07/01/2022

HEAVY & HIGHWAY CONSTRUCTION

	Rates	Fringes
Carpenters:		
Carpenters, Millwrights, Piledrivers.....	\$ 34.88	25.30

-----  
 ELEC0043-001 06/01/2023

	Rates	Fringes
CABLE SPLICER.....	\$ 46.20	30.43
ELECTRICIAN.....	\$ 44.00	3%+30.17

-----  
 ELEC1249-003 05/01/2023

	Rates	Fringes
--	-------	---------



Groundman Truck driver.....	\$ 45.92	7%+35.40
Lineman and Technician.....	\$ 57.40	7%+38.40
Mechanic.....	\$ 45.92	7%+35.40
Substation:		
Cable Splicer.....	\$ 63.14	7%+38.40
Flagman.....	\$ 34.44	7%+35.40
Ground man truck driver....	\$ 45.92	7%+35.40
Groundman digging machine operator.....	\$ 51.66	7%+35.40
Groundman truck driver (tractor trailer unit).....	\$ 48.79	7%+35.40
Lineman & Technician.....	\$ 57.40	7%+38.40
Mechanic.....	\$ 45.92	7%+35.40
Switching structures; railroad catenary installation and maintenance, third rail type underground fluid or gas filled transmission conduit and cable installations (including any and all fiber optic ground product by any other name manufactured for the dual purpose of ground fault protection and fiber optic capabilities), pipetype cable installation and maintenance jobs or projects, and maintenance bonding of rails; Pipetype cable installation		
Cable Splicer.....	\$ 64.59	7%+38.40
Flagman.....	\$ 35.23	7%+35.40
Groundman Digging Machine Operator.....	\$ 52.85	7%+35.40
Groundman Truck Driver (tractor-trailer unit).....	\$ 49.91	7%+35.40
Groundman Truck Driver.....	\$ 46.98	7%+35.40
Lineman & Technician.....	\$ 58.72	7%+38.40
Mechanic.....	\$ 46.98	7%+35.40

FOOTNOTE:

a. PAID HOLIDAYS: New Year's Day, Presidents' Day, Memorial Day, Good Friday, Independence Day, Labor Day, Thanksgiving Day, Christmas Day, and Election Day for the President of the United States and Election Day for the Governor of New York State, provided the employee works two days before or

two days after the holiday.

-----  
ELEC1249-008 01/01/2022

	Rates	Fringes
ELECTRICIAN (Line Construction)		
TELEPHONE, CATV FIBEROPTICS CABLE AND EQUIPMENT		
Cable splicer.....	\$ 36.28	3%+5.14
Groundman.....	\$ 18.25	3%+5.14
Installer Repairman-Teledata Lineman/Technician-Equipment Operator.....	\$ 34.43	3%+5.14
Tree Trimmer.....	\$ 28.25	3%+10.23

a. New Year's Day, President's Day, Good Friday, Decoration Day, Independence Day, Labor Day, Veteran's Day, Thanksgiving Day, Day after Thanksgiving, Christmas Day.

-----  
ENGI0158-020 07/01/2022

	Rates	Fringes
Power equipment operators:		
GROUP 1.....	\$ 48.15	30.55
GROUP 2.....	\$ 47.27	30.55
GROUP 3.....	\$ 43.99	30.55
GROUP 4.....	\$ 52.15	30.55
GROUP 5.....	\$ 51.15	30.55
GROUP 6.....	\$ 50.15	30.55
GROUP 7.....	\$ 49.50	30.55

POWER EQUIPMENT OPERATORS CLASSIFICATIONS

GROUP 1: Asphalt Curb Machine, Self Propelled, Slipform, Automated Concrete Spreader (CMI Type), Automatic Fine Grader, Backhoe (Except Tractor Mounted, Rubber Tired), Backhoe Excavator Full Swing (CAT 212 or similar type), Back Filling Machine, Belt Placer (CMI Type), Blacktop Plant (Automated), Boom truck , Cableway, Caisson Auger, Central Mix Concrete Plant (Automated), Concrete Curb Machine, Self Propelled, Slipform, Concrete Pump, Crane, Cherry Picker, Derricks (steel erection), Dragline, Overhead Crane (Gantry or Straddle type), Pile Driver,

Truck Crane, Directional Drilling Machine, Dredge, Dual Drum Paver, Excavator (All Purpose Hydraulically Operated) (Gradall or Similar), Front End Loader ( 4 cu. yd. and Over), Head Tower (Sauerman or Equal), Hoist (Two or Three Drum), Holland Loader, Maintenance Engineer, Mine Hoist, Mucking Machine or Mole Pavement Breaker(SP) Wertgen; PB-4 and similar type, Power Grader, Profiler (over 105 H.P.) Quad 9, Quarry Master (or equivalent), Scraper, Fireman, Fork Lift, Form Tamper, Grout Pump, Gunite Machine, Hammers (Hydraulic self-propelled), Hydra-Spiker, ride-on, Hydraulic Pump (jacking system), Hydro-Blaster (Water), Mulching Machine, Oiler, Parapet Concrete or Pavement, Shovel, Side Boom, Slip Form Paver, Tractor Drawn, BeltType Loader, Truck or Trailer Mounted Log , Chipper (Self Feeder), Tug Operator (Manned Rented Equipment Excluded), Tunnel Shovel

GROUP 2: Asphalt Paver, Backhoe (Tractor Mounted, Rubber Tired), Bituminous Recycler Machine, Bituminous Spreader and Mixer, Blacktop Plant (NonAutomated), Blast or Rotary Drill (Truck or Tractor Mounted), Boring Machine, Cage Hoist, Central Mix Plant (NonAutomated) and All Concrete Batching Plants, Cherry Picker (5 tons capacity and under), Concrete Paver (Over 16S), Crawler Drill, Self-contained, Crusher, Diesel Power Unit, Drill Rigs, Tractor Mounted, Front End Loader (Under 4 cu. yd.), Greaseman/Lubrication Engineer, HiPressure Boiler (15 lbs. and over), Hoist (One Drum), Hydro-Axe, Kolman Plant Loader and Similar Type Loaders, L.C.M. Work Boat Operator, Locomotive Mixer (for stabilized base selfpropelled), Monorail Machine, Plant Engineer, Profiler (105 H.P. and under), Grinder, Post Hole Digger and Post Driver, Power Broom (towed), Power Heaterman, Power Sweeper, Revinius Widener, Roller (Grade and Fill), Scarifier, ride-on, Shell Winder, Skid steer loader (Bobcat or similar), Span-Saw, ride-on, Steam Cleaner, Pug Mill, Pump Crete Ready Mix Concrete Plant Refrigeration Equipment (for soil stabilization)Road Widener, Roller (all above subgrade), Sea Mule, Self-contained Ride-on Rock Drill, Excluding Air-Track Type Drill, Skidder, Tractor with Dozer and/or Pusher, Trencher. Tugger Hoist, Vermeer saw (ride on, any size or type), Winch, Winch Cat

GROUP 3: A Frame Winch Hoist on Truck , Articulated Heavy Hauler, Aggregate Plant, Asphalt or Concrete Grooving, Machine (ride on), Ballast Regulator, Ride-on Boiler (used in conjunction with production), Bituminous Heater, self-propelled, Boat (powered), Cement and Bin Operator, Compressors, Dust Collectors, Generators, Pumps, Welding Machines, Light Plants, Heaters (hands-off equipment),



Concrete Pavement Spreader and Finisher, Concrete Paver or Mixer (16S and under), Concrete Saw (self-propelled), Conveyor, Deck Hand, Directional Drill Machine Locator, Drill, (Core), Drill, (Well,) Farm Tractor with accessories, Fine Grade Machine, Tamper, ride-on, Tie Extractor, ride-on, Tie Handler, ride-on, Tie Inserter, ride-on, Tie Spacer, ride-on, Tire Repair, Track Liner, ride-on, Tractor, Tractor (with towed accessories), Vibratory Compactor, Vibro Tamp, Well Point

GROUP 4: Tower Cranes

GROUP 5: Cranes 50 tons and over

GROUP 6: Cranes 49 tons and below

GROUP 7: Master Mechanic

FOOTNOTE:

a. New Year's Day, Memorial Day, Independence Day, Labor Day, Thanksgiving Day, Christmas Day provided the employee has worked the working day before and the working day after the holiday.

-----  
 IRON0440-001 07/01/2023

REMANINDER OF COUNTY

	Rates	Fringes
IRONWORKER		
Structural, Ornamental, Rodman, Machinery Mover, Rigger, Fence Erector, Reinforcement, and Stone Derrickman.....	\$ 32.00	31.00

-----  
 LAB00035-002 07/01/2017

	Rates	Fringes
LABORER		
GROUP 1.....	\$ 28.05	23.74+a
GROUP 2.....	\$ 28.25	23.74+a
GROUP 3.....	\$ 28.45	23.74+a
GROUP 4.....	\$ 28.65	23.74
GROUP 5.....	\$ 24.00	20.64+a

FOOTNOTE:

a. Memorial Day, Independence Day, Labor Day, Thanksgiving Day, Christmas Day and New Year's Day provided the employee must work the day before and the work the day after a holiday to receive holiday pay.

GROUP 1: Laborers, flagman, outboard and handboats

GROUP 2: Bull Float, Chain Saw, Concrete aggregate bin, Concrete Bootman, Gin Buggy, Hand or Machine Vibrator, Jackhammer, Mason Tender, Mortor Mixer, Pavement Breaker, Handlers of all steel mesh, Small generators for laborers's tools, Installation of bridge drainage; Pipelayers, Vibrator type rollers, Tamper, Drill doctor, Tail or Screw Operator on asphalt paver, Water pump operator (1 1/2" and single diaphram), Nozzle (aphlat, gunnite, seeding and sand blasting), Laborers on chain link fence erection, Rock splitter and power unit, Pusher type concrete saw and all other gas, electric, oil, and Air tool operators, Wrecking laborers

GROUP 3: All rock or drilling machine operators (except quarry master and similar type), Acetylene torch operators, and Asphalt paver, Powerman

GROUP 4: Blasterers, form setters, stone and granite curb setters

GROUP 5: Hazardous waste removal

-----  
 \* PAIN0004-020 05/01/2023

	Rates	Fringes
Painters:		
Bridges.....	\$ 42.06	30.59

-----  
 PAIN0677-002 05/01/2023

	Rates	Fringes
GLAZIER.....	\$ 26.80	24.19

-----  
 PLUM0112-005 05/01/2023

	Rates	Fringes
--	-------	---------

PLUMBER (Including  
 Steamfitting)  
 Northern Zone.....\$ 41.40                      31.70

-----  
 \* SFNY0669-001 01/01/2024

	Rates	Fringes
SPRINKLER FITTER.....	\$ 42.73	27.05

-----  
 TEAM0182-001 06/01/1996

	Rates	Fringes
Truck drivers:		
GROUP 1.....	\$ 17.37	7.70+a
GROUP 2.....	\$ 17.42	7.70+a
GROUP 3.....	\$ 17.47	7.70+a
GROUP 4.....	\$ 17.62	7.70+a
GROUP 5.....	\$ 17.77	7.70+a

FOOTNOTES:

PAID HOLIDAYS: A-New Year's Day, B-Memorial Day,  
 C-Independence Day, D-Labor Day, E-Thanksgiving Day,  
 F-Christmas Day

a. Paid Holidays: Independence Day and Labor Day provided  
 the employee works his scheduled day before and his  
 scheduled day after the holiday and is on the payroll week  
 in which the holiday falls.

TRUCK DRIVERS:

GROUP 1: Pickups, panel trucks, flatboy material truck  
 (straight jobs), single axle dump trucks, dumpsters,  
 receives, greasers, truck tiremen.

GROUP 2: Tandems, batch trucks, mechanics.

GROUP 3: Semi-trailers, low-boy trucks, asphalt distributors  
 trucks, agitator, mixer trucks and dumpcrete type vehicles,  
 truck mechanic, fuel truck.

GROUP 4: Specialized earth moving equipment-euclid type or  
 similar off-highway equipment where not self-loader, and  
 straddle (ross) carrier, self contained concrete unit

GROUP 5: Off-highway tandem back-dump, twin engine equipment  
 and double hitched equipment where not self-loaded.

-----  
WELDERS - Receive rate prescribed for craft performing operation to which welding is incidental.

=====

Note: Executive Order (EO) 13706, Establishing Paid Sick Leave for Federal Contractors applies to all contracts subject to the Davis-Bacon Act for which the contract is awarded (and any solicitation was issued) on or after January 1, 2017. If this contract is covered by the EO, the contractor must provide employees with 1 hour of paid sick leave for every 30 hours they work, up to 56 hours of paid sick leave each year. Employees must be permitted to use paid sick leave for their own illness, injury or other health-related needs, including preventive care; to assist a family member (or person who is like family to the employee) who is ill, injured, or has other health-related needs, including preventive care; or for reasons resulting from, or to assist a family member (or person who is like family to the employee) who is a victim of, domestic violence, sexual assault, or stalking. Additional information on contractor requirements and worker protections under the EO is available at <https://www.dol.gov/agencies/whd/government-contracts>.

Unlisted classifications needed for work not included within the scope of the classifications listed may be added after award only as provided in the labor standards contract clauses (29CFR 5.5 (a) (1) (iii)).

-----

The body of each wage determination lists the classification and wage rates that have been found to be prevailing for the cited type(s) of construction in the area covered by the wage determination. The classifications are listed in alphabetical order of ""identifiers"" that indicate whether the particular rate is a union rate (current union negotiated rate for local), a survey rate (weighted average rate) or a union average rate (weighted union average rate).

#### Union Rate Identifiers

A four letter classification abbreviation identifier enclosed in dotted lines beginning with characters other than ""SU"" or ""UAVG"" denotes that the union classification and rate were

prevailing for that classification in the survey. Example: PLUM0198-005 07/01/2014. PLUM is an abbreviation identifier of the union which prevailed in the survey for this classification, which in this example would be Plumbers. 0198 indicates the local union number or district council number where applicable, i.e., Plumbers Local 0198. The next number, 005 in the example, is an internal number used in processing the wage determination. 07/01/2014 is the effective date of the most current negotiated rate, which in this example is July 1, 2014.

Union prevailing wage rates are updated to reflect all rate changes in the collective bargaining agreement (CBA) governing this classification and rate.

#### Survey Rate Identifiers

Classifications listed under the "SU" identifier indicate that no one rate prevailed for this classification in the survey and the published rate is derived by computing a weighted average rate based on all the rates reported in the survey for that classification. As this weighted average rate includes all rates reported in the survey, it may include both union and non-union rates. Example: SULA2012-007 5/13/2014. SU indicates the rates are survey rates based on a weighted average calculation of rates and are not majority rates. LA indicates the State of Louisiana. 2012 is the year of survey on which these classifications and rates are based. The next number, 007 in the example, is an internal number used in producing the wage determination. 5/13/2014 indicates the survey completion date for the classifications and rates under that identifier.

Survey wage rates are not updated and remain in effect until a new survey is conducted.

#### Union Average Rate Identifiers

Classification(s) listed under the UAVG identifier indicate that no single majority rate prevailed for those classifications; however, 100% of the data reported for the classifications was union data. EXAMPLE: UAVG-OH-0010 08/29/2014. UAVG indicates that the rate is a weighted union average rate. OH indicates the state. The next number, 0010 in the example, is an internal number used in producing the wage determination. 08/29/2014 indicates the survey completion date for the classifications and rates under that identifier.

A UAVG rate will be updated once a year, usually in January of each year, to reflect a weighted average of the current negotiated/CBA rate of the union locals from which the rate is

based.

---

WAGE DETERMINATION APPEALS PROCESS

1.) Has there been an initial decision in the matter? This can be:

- \* an existing published wage determination
- \* a survey underlying a wage determination
- \* a Wage and Hour Division letter setting forth a position on a wage determination matter
- \* a conformance (additional classification and rate) ruling

On survey related matters, initial contact, including requests for summaries of surveys, should be with the Wage and Hour National Office because National Office has responsibility for the Davis-Bacon survey program. If the response from this initial contact is not satisfactory, then the process described in 2.) and 3.) should be followed.

With regard to any other matter not yet ripe for the formal process described here, initial contact should be with the Branch of Construction Wage Determinations. Write to:

Branch of Construction Wage Determinations  
Wage and Hour Division  
U.S. Department of Labor  
200 Constitution Avenue, N.W.  
Washington, DC 20210

2.) If the answer to the question in 1.) is yes, then an interested party (those affected by the action) can request review and reconsideration from the Wage and Hour Administrator (See 29 CFR Part 1.8 and 29 CFR Part 7). Write to:

Wage and Hour Administrator  
U.S. Department of Labor  
200 Constitution Avenue, N.W.  
Washington, DC 20210

The request should be accompanied by a full statement of the interested party's position and by any information (wage payment data, project description, area practice material, etc.) that the requestor considers relevant to the issue.

3.) If the decision of the Administrator is not favorable, an

interested party may appeal directly to the Administrative Review Board (formerly the Wage Appeals Board). Write to:

Administrative Review Board  
U.S. Department of Labor  
200 Constitution Avenue, N.W.  
Washington, DC 20210

4.) All decisions by the Administrative Review Board are final.

=====

END OF GENERAL DECISION"

# INCORPORATION OF NYSDOT STANDARD SPECIFICATIONS

## NYSDOT STANDARD SPECIFICATIONS

- Except as modified herein, the current Edition of the Standard Specifications, Construction and Materials (Section 100 and Sections 200-700) issued by the New York State Department of Transportation, Office of Engineering, including all revisions and addenda issued by NYSDOT prior to the date the Notice to Bidders is advertised, hereinafter referred to as the NYSDOT Standard Specifications, shall govern the work to be done where referred to on the plans and in these specifications. If a conflict exists between the NYSDOT Standard Specifications and these Contract Documents, the NYSDOT Standard Specification shall govern.

## BASIC MODIFICATIONS

- Where the NYSDOT is mentioned in any capacity (including, but not limited to, Department, State, Commissioner of Transportation, DOT, or Director(s) of its subdivisions) as an approving authority with regard to materials, fabrication, inspections or other approvals, the approving authority shall be changed to the OWNER. This change shall be made in all of the documents pertaining to this contract.
- Unless otherwise described in the Contract Documents, neither the State of New York nor the NYSDOT are parties to this agreement.
- Where the Deputy Chief Engineer (DCE) for any department is mentioned as an approving authority, the approving authority shall be changed to the “Engineer of Record” defined as the Engineer that has signed and sealed construction plans and specifications.
- In the Materials subheadings of the Technical Specifications of the contract documents and the latest edition of the NYSDOT Standard Specifications, the following shall apply:
  - Any references to materials testing by the Department or its representative shall be interpreted to mean by the Contractor, the Owner or its representative. This interpretation also applies to any testing or sampling to be obtained in the presence of a Department representative.
- Any reference to NYSDOT Standard Specifications is limited in scope to technical engineering and construction work, materials, details, procedures, etc. All references to the State or the NYSDOT or administrative officers or employees thereof are null and void with respect to legal or contractual responsibilities.



CHANGE ORDER

NO. \_\_\_\_\_

PROJECT: \_\_\_\_\_

DATE OF ISSUANCE: \_\_\_\_\_ EFFECTIVE DATE: \_\_\_\_\_

OWNER: \_\_\_\_\_

OWNER'S Contract No. \_\_\_\_\_

CONTRACTOR \_\_\_\_\_ ENGINEER Greenman-Pedersen, Inc (GPI)

You are directed to make the following changes in the Contract Documents.

Description: \_\_\_\_\_

Reason for Change Order: \_\_\_\_\_

Attachments: \_\_\_\_\_

<b>CHANGE ORDER IN CONTRACT PRICE:</b>	<b>CHANGE IN CONTRACT TIMES:</b>
Original Contract Price: \$ _____	Original Contract Times Substantial Completion: _____ (days or dates)
Net changes from previous Change Orders No. _____ to _____ \$ _____	Net changes from previous Change Orders No. _____ to _____ \$ _____ days
Contract price prior to this Change Order: \$ _____	Contract Times prior to this Change Order Substantial Completion: _____ _____
Net increase (decrease) of this Change Orders \$ _____	Net increase (decrease) of this Change Orders _____ days
Contract price with all approved Change Orders: \$ _____	Contract Times with all approved Change Orders Substantial Completion: _____ _____

This change order represents full and complete compensation for all costs relative to the change itself and all other impacts on the project. Contractor hereby acknowledges that it has considered and priced into this change order impacts beyond the scope of the individual change order and waives all claims otherwise.

<b>RECOMMENDED:</b>	<b>APPROVED:</b>	<b>ACCEPTED:</b>
BY: _____ Engineer (Authorized Signature)	BY: _____ Owner (Authorized Signature)	BY: _____ Contractor (Authorized Signature)

Date: \_\_\_\_\_ Date: \_\_\_\_\_ Date: \_\_\_\_\_

**ACCEPTED:**

BY: \_\_\_\_\_  
NYSDOT (Authorized Signature)

Date: \_\_\_\_\_

EJCDC NO. 1910-8-B (1990 Edition)

Prepared by the Engineers Joint Contract Documents Committee and endorsed by The Associated General Contractors of America

**NOTICE OF AWARD**

Dated: \_\_\_\_\_, 20 \_\_\_\_

TO: \_\_\_\_\_

ADDRESS: \_\_\_\_\_

PROJECT: \_\_\_\_\_

OWNER'S CONTRACT NO. \_\_\_\_\_

CONTRACT FOR \_\_\_\_\_

(Insert name of Contract as it appears in the Bidding Documents)

You are notified that your Bid dated \_\_\_\_\_, 20 \_\_\_\_ for the above Contract has been considered. You are the apparent Successful Bidder and have been awarded a contract for \_\_\_\_\_

(Indicate total Work, alternates or sections or Work awarded)

The Contract Price of your contract is \_\_\_\_\_ Dollars (\$ \_\_\_\_\_).  
(figures)

[Insert appropriate data in re Unit Prices. Change language for Cost-Plus contracts.]

\_\_\_\_\_ copies of each of the proposed Contract Documents (except Drawings) accompany this Notice of Award.

\_\_\_\_\_ sets of the Drawings will be delivered separately or otherwise made available to you immediately.

You must comply with the following conditions precedent within fifteen days of the date of this Notice of Award, that is by \_\_\_\_\_, 20 \_\_\_\_ .

1. You must deliver to the OWNER fully executed counterparts of the Agreement including all the Contract Documents. This includes the triplicate sets of Drawings. Each of the Contract Documents must bear your signature on (the cover) (every) page (pages \_\_\_\_).
2. You must deliver with the executed Agreement the contract Security (Bonds) as specified in the Instructions to Bidders (paragraph 18).

3. (List other conditions precedents).

---

---

---

---

---

---

---

---

---

---

Failure to comply with these conditions within the time specified will entitle OWNER to consider your bid in default, to annul this Notice of Award and to declare your Bid Security forfeited.

Within ten days after you comply with the above conditions. OWNER will return to you one fully signed counterpart of the Agreement the Contract Documents attached.

\_\_\_\_\_  
(OWNER)

By: \_\_\_\_\_

(AUTHORIZED SIGNATURE)

\_\_\_\_\_  
(TITLE)

**ACCEPTANCE OF AWARD**

\_\_\_\_\_  
(CONTRACTOR)

By: \_\_\_\_\_

(AUTHORIZED SIGNATURE)

\_\_\_\_\_  
(TITLE)

\_\_\_\_\_  
(DATE)

COPY to ENGINEER  
(Use Certified Mail.  
Return Receipt Requested)

**NOTICE TO PROCEED**

Dated: \_\_\_\_\_, 20 \_\_

TO: \_\_\_\_\_

ADDRESS: \_\_\_\_\_

PROJECT: \_\_\_\_\_

OWNER'S CONTRACT NO. \_\_\_\_\_

CONTRACT FOR \_\_\_\_\_

(Insert name of Contract as it appears in the Bidding Documents)

You are notified that the Contract Times under the above contract will commence to run on \_\_, 20\_\_. By that date, you are to start performing your obligations under the Contract Documents. In accordance with Article 3 of the Agreement the dates of Substantial Completion and completion and readiness for final payment are October 25, 2025, and November 7, 2025.

Before you may start any Work, you and Owner must each deliver to the other (with copies to ENGINEER and other identified additional insureds) certificates of insurance which each is required to purchase and maintain in accordance with the Contract Documents.

Also before you may start any Work at the site, you must (add other requirements)

\_\_\_\_\_  
\_\_\_\_\_  
\_\_\_\_\_

\_\_\_\_\_  
(OWNER)

By: \_\_\_\_\_  
(AUTHORIZED SIGNATURE)

\_\_\_\_\_  
(TITLE)

**ACCEPTANCE OF AWARD**

By: \_\_\_\_\_  
(CONTRACTOR)

\_\_\_\_\_  
(AUTHORIZED SIGNATURE)

\_\_\_\_\_  
(TITLE)

\_\_\_\_\_  
(DATE)

Copy to ENGINEER  
(Use Certified Mail,  
Return Receipt Requested)

## **Special Notes**

**SPECIAL NOTES: (PIN 2650.57)**

The following items are SPECIAL NOTES:

**Description**

- GENERAL SPECIAL NOTES
- ENGINEERING INSTRUCTIONS AND ENGINEERING BULLETINS
- QUALITY ASSURANCE/QUALITY CONTROL SPECIAL NOTE
- EMERGENCY CONTACTS
- ASPHALT AND FUEL PRICE ADJUSTMENT
- GREEN CONSTRUCTION SPECIAL NOTES
- INSURANCE
- MODIFICATION TO INSURANCE
- NOISE POLLUTION
- SPILLAGE OF OIL OR HAZARDOUS SUBSTANCES
- TEMPORARY LANE/SHOULDER CLOSURE RESTRICTIONS FOR MAJOR HOLIDAYS
- CONTRACT DURATION
- BUY AMERICAN
- ELECTRICAL SAFETY
- 511 NY
- RIGHT OF WAY
- QA FOR PROJECTS ON STATE OR NATIONAL HIGHWAY SYSTEM
- COORDINATION WITH UTILITY SCHEDULE

**GENERAL SPECIAL NOTES**  
**DOWNTOWN ROME WHEELS TO HEELS STREETSCAPE**

**A. EXISTING PRIVATE PROPERTY MARKERS:**

The Contractor's attention is directed to the fact that any existing iron pins, stakes, survey monuments or other markers defining property lines which may be disturbed during construction, shall be properly tied into fixed reference points before being disturbed and accurately reestablished to their proper position upon completion of the work.

The cost of survey to tie and reestablish property marker locations shall be included in the lump sum price bid for item 625.01 – Survey Operations.

**B. ITEM 625.01 – SURVEY OPERATIONS**

In addition to the proposed work required under Item 625.01 – Survey Operations, the Contractor may also be required to provide for the specific layout of curb lines, sidewalks, drainage structures and pipes, and existing and proposed roadway boundaries for use by the utility companies performing utility relocations within the Contract limits. The price bid for Item 625.01 – Survey Operations, shall include all work necessary for the survey and stakeout required for the utility relocations.

**C. COORDINATION WITH EMERGENCY RESPONSE SERVICES:**

The State Police, City of Rome Police Department, Oneida County Sheriff's Department, Fire Departments and Ambulance units servicing this area shall be given a minimum of two (2) weeks advance notice of changes in all traffic patterns, including lane closures, necessary to meet construction requirements. Such other agencies including school districts, disaster relief, etc. shall be notified by published notice prior to the inception of any changes in the traffic patterns. The Contractor shall notify the Engineer in a timely manner of any changes in the traffic patterns so the Engineer can make advance notifications.

**D. COORDINATION WITH OTHER CONSTRUCTION CONTRACTS**

The Contractor shall be aware of any other construction contracts within the area which may be occurring along local, County or State highways. The Engineer will maintain contact with those projects. The Engineer shall coordinate closures between the projects. If the Engineer deems it necessary to suspend work at various times due to traffic issues the Contractor shall comply. Any cost due to work modifications shall be included in other items of work.

**E. COORDINATION WITH UTILITY COMPANIES**

Utility facility adjustments and/or relocations are anticipated for this project. When the City determines that utility facility adjustments and/or relocations are necessary, the provisions of Section 102-09 Other Contracts, Coordination and Access will apply. Any such adjustments and/or relocations will be performed by the Utility owners and/or the contractor upon direction by the RE/EIC. Suitable time frames for these additions shall be coordinated between the City, the Contractor, and the affected Utility. The contractor is governed by and must adhere to the provisions of 16 NYCRR Part 753 (Protection of Underground Facilities).

**GENERAL SPECIAL NOTES**  
**DOWNTOWN ROME WHEELS TO HEELS STREETSCAPE**

**F. CONTRACTOR SUBMITTALS**

The Contractor shall include a Letter of Transmittal, which includes a uniquely identifiable transmittal number for each transmittal being sent, on all submittals to the EIC. All shop drawing transmittals shall also carry a uniquely identifiable transmittal number and letter from the Contractor.

**G. SUBCONTRACTORS, SUPPLIERS AND MATERIAL SOURCES**

The Contractor shall submit to the Resident Engineer for approval at the pre-construction meeting all subcontractors, suppliers and material sources anticipated to be used on the project.

**H. SHOP DRAWINGS**

The Contractor shall submit to the Resident Engineer shop drawings for various items to be provided in the Contract for review and approval. The Contractor must submit this information for review and approval a minimum of ten (10) calendar days prior to the scheduled installation of such items.

**I. MATERIAL STOCKPILES**

The Contractor shall not stockpile earth or other materials in a manner conducive to erosion, or in areas likely to cause high turbidity runoff during storm events. All exposed soils shall be re-vegetated in a timely manner to further reduce potential erosion effects.

**J. MATERIAL DISPOSAL**

The Contractor is advised there are no disposal sites within the project available for disposal of excess material. The Contractor shall remove all excess material from the site. Any material stockpiled awaiting disposal shall be stockpiled in upland areas and be suitably stabilized so that it cannot re-enter any waterway or wetland.

**K. SPECIAL MATERIAL DISPOSAL**

City-Owned Signs – All City owned signs and sign posts removed within the project limits shall be returned to the City's DPW storage facility as directed by the resident engineer.

Frame and grates shall be returned to the Department of Public Works yard.

**L. PRIVATE FEATURES WITHIN THE PUBLIC RIGHT-OF-WAY**

The Contractor shall contact adjacent property owners 2 weeks prior to removing private features noted in the table on the plans prior to removal. This will allow the owner the opportunity to remove the feature or provide information for a location the feature should be placed outside the project limits.



**GENERAL SPECIAL NOTES**  
**DOWNTOWN ROME WHEELS TO HEELS STREETSCAPE**

**M. EROSION CONTROL DEVICES**

The Contractor shall ensure that all synthetic erosion control devices, which are intended for temporary use during construction, are completely removed and properly disposed of after site stabilization has occurred. Only natural fiber materials, which will degrade over time, may be used as permanent measures, or if used temporarily, may be abandoned in place.

**N. UNPAVED/MILLED ROAD SURFACE**

Traffic shall not be allowed to travel on an unpaved roadway surface (gravel) for more than 15 calendar days. Traffic may be run on milled surface for a maximum of 10 (Ten) consecutive weekdays excluding holidays prior to completing pavement through binder or top course.

**O. TRAFFIC CONTROL**

The Contractor will be responsible for providing traffic control. All traffic control signage and devices shall be in accordance with the Contract Plans, Federal Manual of Traffic Control Devices, NYSDOT Standard Sheets, NYS Supplement and the Official Compilation - Codes, Rules, and Regulations of the State of New York.

**P. DIG SAFELY NY**

The Contractor shall have underground utilities marked in the field prior to excavation activities.

**Q. ITEM 206.05 – TEST PIT EXCAVATION**

Test pits shall be utilized when necessary to locate existing underground utilities. The price bid for locating existing underground utilities shall be included under Item 206.05 – Test Pit Excavation. Additional test pit may be required by AOB E during construction.

**R. SITE SAFETY**

The Contractor shall perform all work in a workmanlike manner with due regard to the safety of the employees and of the public. The Contractor shall comply with all rules, regulations and standards of the Occupational Safety and Health Administration, U.S. Department of Labor in the performance of the work required by the Contract Documents in all matters regarding the safety and protection of persons employed in construction, excavation and demolition work. The Contractor shall also meet all applicable requirements of the State of New York Department of Labor, Industrial Code Rule 53 regarding construction, excavation and demolition operations at or near underground facilities. The Contractor is fully and solely responsible for site safety precautions.

The Contractor shall be responsible for initiating, maintaining and supervising all safety precautions and programs in connection with the work. The Contractor shall take all necessary precautions for the safety of, and shall provide the necessary protection to prevent damage, injury or loss of:

- a. all employees on the site and other persons who may be affected thereby;
- b. all the work and all products to be incorporated therein, whether in storage on or off the site; and
- c. other property at the site or adjacent thereto, including trees, shrubs, lawns, walks, pavements, roadways, structures and utilities not designated for removal, relocation or replacement in the course of construction.

**GENERAL SPECIAL NOTES**  
**DOWNTOWN ROME WHEELS TO HEELS STREETSCAPE**

The Contractor shall assume all responsibility for damage to persons or property which may occur during the prosecution of the work and shall replace or make good any such damage, loss or injury.

**S. PRE-CONSTRUCTION MEETING**

A PRE Bid Meeting is not being held for this project. After award a Pre-Construction meeting that includes the Local Project Unit Construction liaison is required.

**T. PERMITS**

Contractor shall obtain prior to start of work all necessary permits including but not limited to a Highway Work Permit from the NYSDOT. The Highway Work Permit shall cover all work along NY 46 including but not limited to sidewalk, striping, drainage and detour routes. Contractor shall be responsible for all temporary traffic control in accordance with the national Manual of traffic control devices and the NYS supplement and these plans.

**SPECIAL NOTES**  
**NYSDOT STANDARD SPECIFICATIONS**

All applicable Engineering Instructions and Engineering Bulletins which have been issued by the NYSDOT to modify the “New York Standard Specifications” are made part of the Contract Documents although they are not included with the Contract Documents. They are available to be viewed and downloaded at the New York State Department of Transportation website at ([www.nysdot.gov](http://www.nysdot.gov)). It shall be the Contractor’s responsibility to implement the most current and complete Standard Specifications.

**UPDATES AND MODIFICATIONS TO 2024 STANDARD SPECIFICATIONS (NYSDOT)**

Prospective bidders are hereby notified that the NYSDOT Standard Specifications for Construction and Materials have been updated multiple times by NYSDOT. The NYSDOT’s website contains an unofficial copy of updated Standard Specifications. It is located at:

<https://www.dot.ny.gov/main/business-center/engineering/specifications/updated-standard-specifications-us>

The responsibility of maintaining an up-to-date copy of the Standard Specifications lies solely with the prospective bidders and as such, the references provided herein are for information purposes only. In order to obtain all updates and modifications to the Standard Specifications, prospective bidders should consult the NYSDOT’s Engineering Information Issuance System. It is located at:

<https://www.dot.ny.gov/eieb>

Prospective bidders who do not have a copy of the Standard Specifications may download a copy from the following website

<https://www.dot.ny.gov/main/business-center/engineering/specifications/2008-standard-specs-us>

Alternatively, prospective bidders who do not have a copy of the Standard Specifications may order a copy by contacting the NYSDOT Plan Sales Unit at:

NYSDOT Plan Sales Section  
50 Wolf Road, 1<sup>st</sup> Floor  
Albany, NY 12232  
Tel (518) 457-2124  
Fax (518) 457-2624

**SPECIAL NOTE**  
**EMERGENCY CONTACTS**

The Contractor shall employ, for the duration of the Contract a telephone answering service to meet the requirements stated in Section 107-05 of the Standard Specifications.

The answering service shall be equipped to receive calls on a 24-hour basis and promptly contact Contractor personnel with the authority and capacity to mobilize forces to respond to an emergency.

The following action shall be taken after an emergency call is received.

A. During Normal Work Hours:

1. The Contractor's responsible person shall respond to the person or agency that initiated the call within 30 minutes from the time the answering service received the call.
2. Immediately following the return call to the initiator, he should contact the Engineer advising of the situation and what action he plans to take. If the Engineer is not reachable at the Project Field Office, he should leave a message on the Engineer's answering machine and contact the City of Rome Department of Public Works at (315) 336-6000 with the same information.
3. The Contractor shall respond to the emergency and make the follow-up confirmatory calls as directed by the Engineer or the City of Rome Department of Public Works.

B. During Non-Working Hours:

1. The Contractor's responsible person shall respond to the person or agency that initiated the call within 30 minutes from the time his answering service received the call. If the call initiated from a person or agency other than the City of Rome Department of Public Works, the contractor shall immediately notify the Engineer of the situation and the action planned by contacting Greenman-Pedersen, Inc. at (518) 898.9512 and leaving a message.
2. If work is required at the project site, the Contractor's responsible person shall be at the site within one hour from the time of the initiator's original call.
3. Follow-up call within two hours of the original call shall be made to the original caller, the City of Rome Department of Public Works and to Greenman-Pedersen, Inc. advising the status of the emergency and the actions taken. At the same time, a message shall be left on the Engineer's field office answering machine with the same information.



**Department of  
Transportation**

**ENGINEERING  
BULLETIN**

**EB  
24-013**

Title: **FUEL, ASPHALT & STEEL PRICE ADJUSTMENTS (APRIL 2024)**

Approved:

*Erica Gundrum*

3/25/24

Date

Erica Gundrum, Director  
Contract Administration Bureau  
(Office of Construction)

**Expires one year after issue unless replaced sooner**

**This Bulletin replaces EB 24-009.** On or about the 25<sup>th</sup> of each month, this information is made available on the NYSDOT website at: <https://www.dot.ny.gov/main/business-center/contractors/construction-division/fuel-asphalt-steel-price-adjustments>.

The following information is to be used in computation of progress and final payments for the fuel, asphalt, and steel price adjustment pay items. Instructions for calculating these payments are contained in Section 698 of the Standard Specifications.

<b>AVERAGE POSTED PRICES FOR FUEL</b>			
	<b>2024</b>	<b>2023</b>	<b>2022</b>
	<b>\$/gallon</b>	<b>\$/gallon</b>	<b>\$/gallon</b>
<b>January</b>	2.50	2.67	2.36
<b>February</b>	2.44	3.10	2.60
<b>March</b>	2.60	2.64	2.76
<b>April</b>	2.69	2.58	3.50
<b>May</b>		2.68	3.67
<b>June</b>		2.59	4.13
<b>July</b>		2.70	4.28
<b>August</b>		2.68	3.68
<b>September</b>		3.00	3.54
<b>October</b>		3.03	2.96
<b>November</b>		2.89	3.65
<b>December</b>		2.61	3.26
<b>AVERAGE POSTED PRICES FOR ASPHALT</b> (Performance-Graded Binder)			
	<b>2024</b>	<b>2023</b>	<b>2022</b>
	<b>\$/Ton</b>	<b>\$/Ton</b>	<b>\$/Ton</b>
<b>January</b>	616	626	580
<b>February</b>	602	608	605
<b>March</b>	609	617	624
<b>April</b>	604	612	655
<b>May</b>		621	719
<b>June</b>		635	779
<b>July</b>		640	824
<b>August</b>		645	829
<b>September</b>		645	806
<b>October</b>		646	764
<b>November</b>		630	690
<b>December</b>		615	640

## EB 24-013 Page 2 of 2

The following table lists Producer Price Indexes (PPI) from the USDOL Bureau of Labor Statistics (BLS) along with a listing of initial cost basis (CB) values for steel/iron products. The final PPI is usually available 4 months after publication of the preliminary PPI. Preliminary PPI data is subject to change by BLS.

<b>PRODUCER PRICE INDEXES (PPI) FOR WPU 101702 - SEMI FINISHED STEEL MILL PRODUCTS</b>									
	<b>2024</b>			<b>2023</b>			<b>2022</b>		
	<b>Prelim PPI*</b>	<b>Final PPI</b>	<b>Cost Basis</b>	<b>Prelim PPI*</b>	<b>Final PPI</b>	<b>Cost Basis</b>	<b>Prelim PPI*</b>	<b>Final PPI</b>	<b>Cost Basis</b>
			<b>(\$/ton)</b>			<b>(\$/ton)</b>			<b>(\$/ton)</b>
<b>January</b>	431.1	-	1120	437.1	437.6	1313	476.7	476.7	1392
<b>February</b>	426.1	-	1128	442.3	442.3	1232	475.6	475.6	1405
<b>March</b>		-	1172	446.4	446.4	1225	482.6	482.7	1408
<b>April</b>		-	1144	456.8	456.8	1220	506.1	507.1	1385
<b>May</b>		-		461.3	461.3	1260	516.0	516.0	1459
<b>June</b>		-		459.9	459.9	1266	510.2	510.2	1519
<b>July</b>		-		451.8	451.8	1245	502.4	502.4	1510
<b>August</b>		-		448.0	448.0	1233	484.3	484.3	1485
<b>September</b>		-		442.1	442.1	1230	468.4	468.4	1456
<b>October</b>		-		436.7	436.7	1186	454.7	454.7	1401
<b>November</b>		-		420.3	-	1171	447.6	447.6	1377
<b>December</b>		-		422.0	-	1160	433.0	433.0	1319

\*Preliminary PPI derived from the Annual Average PPI posted by the USDOL Bureau of Labor Statistics.

**CONTACT:** For additional information regarding this issuance, contact Erica Gundrum in the Office of Construction at [Erica.Gundrum@dot.ny.gov](mailto:Erica.Gundrum@dot.ny.gov) or (518) 485-1592.

**SPECIAL NOTES**  
**GREEN CONSTRUCTION REQUIREMENTS**

**ULTRALOW SULFURDIESEL FUEL**

In order to reduce diesel emissions, the Contractor shall use Ultra Low Sulfur Diesel (ULSD) fuel to operate all diesel engines used to complete the work that will operate for 10 hours or more on the contract site. ULSD fuel requirements shall apply to:

- All diesel engines/equipment.
- Stationary and mobile equipment.
- Owned, leased and rented equipment.

The hours the piece of equipment is used to complete the work is defined as the actual time the engine is running. The time may be continuous or discontinuous and includes warm-up periods idling, in traffic periods, etc.

The term “Contractor” is intended to mean both Prime Contractors and Subcontractors. Materials delivery vehicles not owned by the Contractor/Subcontractor are exempt from this requirement, but should minimize idling time at construction sites whenever possible.

The Contractor will be notified when any diesel-powered construction equipment is in noncompliance. Non-compliance shall be corrected within a 24-hour period.

**SPECIAL NOTES**  
**GREEN CONSTRUCTION REQUIREMENTS**

**CONTROLLING EXPOSURE TO DIESEL EXHAUST**

The Contractor shall exercise measures to protect “Sensitive Receptors” from the impacts of diesel exhaust fumes. Sensitive Receptors include, but are not limited to: hospitals, schools, daycare facilities, building fresh air or ventilation intakes, elderly housing or convalescent facilities. The Contractor shall ensure that diesel powered engines are located away from building air conditioners and windows.

The goal is to minimize exposure of Sensitive Receptors in close proximity to diesel exhaust, in terms of both concentration and time. In general, close proximity is defined as within 15 meters of a Sensitive Receptor. Mitigation techniques include positioning stationary equipment exhausts greater than 15 meters from Sensitive Receptors, extension of equipment exhausts through the use of flexible tubing; protecting building air intakes; and the use of moving operations.

Idling time for diesel powered equipment shall be limited to three consecutive minutes for Delivery and dump trucks and all other diesel powered equipment except as follows:

- When a “mobile source” (vehicle) is forced to remain motionless because of traffic conditions or mechanical difficulties over which the operator has no control.
- When it is necessary to operate a loading, unloading or processing device.
- When the outdoor temperature is less than -3°C (27°F).
- When the “mobile source” is being repaired.

Arrow panels and portable variable message signs shall be solar powered wherever possible or practical.

Whenever possible and practicable, the Contractor shall establish staging areas for diesel powered vehicles waiting to load or unload materials at the work site. Such areas shall be located where diesel emissions have the least impact on Sensitive Receptors and the general public.



**SPECIAL NOTES**  
**GREEN CONSTRUCTION REQUIREMENTS**

**DUST CONTROL**

The Contractor shall minimize dust from disturbed soil surfaces or other materials that can cause off-site damage, health hazards and traffic safety problems. Dusty conditions resulting from the Contractor's operations shall be corrected at no additional cost to the Village. Buffer areas of vegetation should be left where practical. Water quality shall be considered when selecting materials for dust control. An approved dust palliative may be used in conformance with applicable conditions placed on its use. A list of acceptable dust palliatives is available at:

[www.nysdot.gov/divisions/engineering/technical-services/geotechnical-engineering-bureau/dust-palliatives](http://www.nysdot.gov/divisions/engineering/technical-services/geotechnical-engineering-bureau/dust-palliatives)

For areas not subject to traffic, products and materials may be applied or placed on soil surfaces to prevent airborne migration of soil particles, including:

- Vegetative Cover—provides the most practical method of dust control.
- Mulch (including rolled erosion control products)—provides a fast, effective method of dust control.
- Spray Adhesives—Generally composed of polymers in a liquid or solid form mixed with water to form an emulsion that is sprayed on the soil surface. The mixing ratios and application rates will be in accordance with the manufacturer's recommendations for the specific soils on the site. Adhesives shall not be applied to wet soils or if there is a probability of precipitation within 48 hours.
- For areas subject to traffic (traveling public or construction traffic) products and materials may be applied or placed on soil surfaces to prevent airborne migration of soil particles, including:
  - Water Sprinkling—The site may be sprayed with water until the surface is wet. This is especially effective on haul roads and access routes.
  - Polymer Additives—Polymers shall be mixed with water and applied to the driving surface using mixing ratios and application rates in accordance with the manufacturer's recommendations. No application of the polymer will be made if there is a probability of precipitation within 48 hours of its proposed use. Any polymers must be used in accordance with the NYSDEC issued "Conditions for Use" and "Application Instructions." This information can be obtained from the NYSDEC website.
  - Barriers—Woven geotextiles or stone can be placed on the driving surface to effectively reduce dust throw and particle migration on haul roads.
  - Windbreak—A silt fence or similar barrier can control air currents at horizontal intervals equal to ten times the barrier height. Preserve existing vegetation that acts as a wind barrier as much as practical.
  - Wheel Washing—Mechanical or manual wet-method cleaning of on-road construction vehicle tires prior to leaving site.

## **SPECIAL NOTE**

### **INSURANCE**

This special note serves as a supplement to insurance requirements listed in the Invitation to Bidders section in this Manual and Section 107-06 of the New York State Department of Transportation Standard Specifications dated May 1, 2024.

The following parties shall be named as additional insured for all those activities performed within its contracted activities for the contract as executed:

**City of Rome  
Greenman-Pedersen, Inc  
Federal Highways Administration  
NYS Department of Transportation**

Coverage must also be provided for any consultant inspecting engineer or inspector (and their agents) working for or on the project.

The above listing supplements Section 107-06 INSURANCE of the New York State Department of Transportation Standard Specifications dated May 1, 2024.

## **SPECIAL NOTE**

### **INSURANCE COVERAGE**

By virtue of the scope, location, type, and/or estimated value, the following types of insurance, listed in the Standard Specifications §107-06B, do not apply to this project and the Contractor is under no obligation to furnish proof of such insurance.

Professional Liability/ Errors and Omissions is not required unless the Contractor intends to include professional services requiring the signature, stamp or certification of a licensed professional, including, without limitation, erection plans, demolition plans, containment plans, coffer dams, and temporary sheeting.

Pollution Liability Insurance is not required unless the Contractor will employ mobile equipment or tanks or facilities for fueling vehicles or equipment on-site. The Contractor will only use licensed and registered vehicles that are covered by a Commercial Automobile Policy, or provide the Pollution Liability Insurance.

Marine Protection & Indemnity Insurance is not required because the project scope does not require any Work performed on a navigable waterway using barges or other watercraft.

Builders' Risk Policy is not required because the project scope does not require the construction of a structure or building and/or the project is valued at less than the threshold amount.

Railroad Protective Liability Insurance is not required because the project scope does not require Work Affecting Railroads as described in §105-09.

## **SPECIAL NOTE**

### **NOISE POLLUTION**

The Contractor shall comply with all Federal, State and Local sound control and noise level rules, regulations and ordinances that apply to any work performed under the contract.

The proximity of commercial or private properties in the vicinity of the project will require that noise control procedures be utilized to limit the noise impact of the work on the ambient noise levels in the area.

These noise control procedures shall consist of any or all of the following measures:

1. Source control
  - a. Equipment mufflers where applicable.
  - b. Maintenance and operations.
  - c. Adherence to equipment noise level emission requirements.
2. Site control of overall noise level.
3. Time and activity constraints.
4. Public awareness of the work.

The Contractor's operations shall be performed in such a manner that contract work related noise levels do not exceed the ambient noise levels. During work hours, the maximum allowable exterior noise level as measured at the exterior of any building shall be 88 db(A). In the event ambient noise levels exceed the above criteria, a noise level increase of 10 db(A) or greater during the above periods will be considered adverse. In the event construction noise levels exceed the noted levels, the Contractor shall take such action as necessary to conform with this provision prior to proceeding with his operations.

The Contractor shall be responsible for all costs arising from delay of operation(s) due to noncompliance with noise control procedures. Conformance to such regulation will not be deemed as a basis for claim for either extension of time or increased compensation. Full compensation shall be considered as included in the prices paid for the various contract items of work involved.

The City reserves the right to monitor the noise levels produced by the construction operations as deemed necessary, or in response to the concerns of residents in the area.

## **SPECIAL NOTE**

### **SPILLAGE OF OIL OR HAZARDOUS SUBSTANCES**

Spillage of oil and other hazardous substances is especially prohibited by Section 311 of the Clean Water Act of 1977. The contractor shall be responsible to incorporate measures and procedures to prevent spillage of hazardous substances. These measures shall include proper maintenance of construction equipment, designation of special fuel/hazardous substance handling areas which allow spills to be contained before reaching the waterway, and instructions to personnel that oil or other hazardous materials must never be poured into drains or waterways.

If, in spite of the above prevention measures, oil or hazardous substances is spilled onto soils or into a watercourse, the Contractor must provide immediate notification to the following:

- 1. N Y S Department of Environmental Conservation Spills Hotline (518) 457-7362**
- 2. National Response Center 1-800-424-8802**
- 3. Resident Engineer**

A supply of straw or other absorbent material must be readily available to the Contractor at all times so that it may be rapidly deployed to soak up any possible spillage, pending NYSDEC and/or US Coast Guard arrival on the scene. The use of chemical dispersing agents and emulsifiers is not authorized without prior, specific, Federal or State approval.

**SPECIAL NOTE**  
**TEMPORARY LANE/SHOULDER CLOSURE RESTRICTIONS FOR MAJOR HOLIDAYS**

There shall be no temporary lane/shoulder closures on roadway facilities owned and/or maintained by NYSDOT on the major holidays listed below.

Construction activities that will result in temporary lane/shoulder closures shall be suspended to minimize travel delays associated with road work for major holidays as follows:

<b>Holiday</b>	<b>Falls on</b>	<b>Temporary lane closures are NOT allowed from</b>
New Year's Day Independence Day Christmas Day	Sunday or Monday	6:00 AM Friday before to 6:00 AM Tuesday after
	Tuesday	6:00 AM Saturday before to 6:00 AM Wednesday after (starting at 6:00 AM Friday before to 6:00 AM Wednesday after for Christmas Day)
	Wednesday	6:00 AM Tuesday before to 6:00 AM Thursday after (starting at 6:00 AM Saturday before to 6:00 AM Thursday after for Christmas Day)
	Thursday	6:00 AM Thursday to 6:00 AM Monday after (starting at 6:00 AM Wednesday before to 6:00 AM Monday after for Christmas Day)
	Friday or Saturday	6:00 AM Thursday before to 6:00 AM Monday after

<b>Holiday</b>	<b>Falls on</b>	<b>Temporary lane closures are NOT allowed from</b>
Memorial Day Labor Day	Monday	6:00 AM Friday before to 6:00 AM Tuesday after
Thanksgiving Day	Thursday	6:00 AM Wednesday before to 6:00 AM Monday after

Exceptions can only be made under the following conditions:

- Emergency work.
- Work within long-term stationary lane/shoulder closures.
- Safety work that does not adversely impact traffic mobility and has been authorized by the Regional Traffic Engineer.

Note: The Department reserves the right to cancel any work operations, including lane closures and/or total road closures, that would create traffic delays by unforeseen events. The Contractor would be notified at least seven (7) calendar days prior to the proposed work.

**SPECIAL NOTE**  
**BUY AMERICAN**

All steel and/or iron products for this project, including any steel or iron used in the fabrications of signs, signal poles, catch basins or other items used on federal aid projects to be 100% domestic in origin. It is the Contractor's responsibilities to ensure that domestic steel or iron materials are used for this project.

## **SPECIAL NOTE** **ELECTRICAL SAFETY**

This proposal insert note contains policy and procedures for working near energized electrical systems. It is based on OSHA standards, the NYS High Voltage Proximity Act, and Highway Law. It applies to all operations in the contract that could cause employees or the vehicles or equipment they are operating to come into contact with or enter into dangerous proximity to energized electrical systems.

NYS High Voltage Proximity Act applies to electrical systems carrying 600 volts or more and requires employers to:

- Ensure employees are not placed in proximity to high voltage. Proximity is defined as within 10 feet (3,048mm) for voltages up to 50 kilovolts.
- Inform employees of the hazards and corresponding precautions when working near high voltage.
- Post warning decals on equipment regarding 10-foot (3,038mm) minimum clearance.
- Ensure that when an equipment operator is unable to assess clearances a “spotter” observes for clearance and directs the operator.
- Notify the utility at least five (5) working days before any work begins which requires the utility to identify voltages and clearances, or de-energize, insulate or relocate lines.

Failure to comply with any of these provisions is a violation of law and a serious breach of public safety policy and procedure and the Engineer will issue a stop work for any operation that is not in compliance.

### **PROCEDURES**

**GENERAL:** Prior to the start of work where contact with energized electrical systems is possible, the Contractor shall identify energized lines or equipment and reference their location to prominent physical features. In addition, the Contractor shall mark the pavement beneath overhead lines with spray point, survey tape, or with high visibility markers and shall maintain all markings during the period they are required.

The owners of the utilities shall be called upon to decide the need to de-energize or insulate the lines or for the need to otherwise protect the lines against accidental contact. The actual work of protecting the lines shall be carried out by their owners. Protection provided at the request of the Owner, with respect to utility facilities located within the highway right-of-way shall be the sole financial responsibility of the utility. In addition, upon request, the utility at its sole expense shall provide necessary information concerning its high voltage facilities to the Owner and its contractors and subcontractors. Protection provided for the benefit of or at the request of a contractor or subcontractor of the Owner shall be the financial responsibility of the contractor or subcontractor.

The location of electrical lines and the precautions and safeguards to be taken shall be discussed at pre-work safety meetings with all employees on the job. New employees will be informed of electrical hazards and proper procedures at the work site.

The Contractor shall identify and reference all potential electrical hazards and document such actions as part of the Safety Plan for the project. Energized electrical lines or equipment shall be conspicuously marked and workers shall be reminded of their locations and the safeguards and precautions to be taken



**SPECIAL NOTE**  
**ELECTRICAL SAFETY**

prior to beginning any nearby work that may cause the workers to approach electrical lines. New employees shall be informed of electrical hazards and proper precautions and procedures.

Requirements for specialized work shall be as follows:

1. Paving, Patching, Chip Sealing or Widening. Prior to the start of each workday high visibility markers or other devices approved by the Engineer shall be placed to mark the location of overhead wires. As an alternative, the pavement beneath overhead lines may be marked with spray paint or by other means approved by the Engineer. This requirement shall also apply to off-site areas used for contract purposes. The Contractor shall periodically patrol the worksite to ensure that the markings are in place and shall replace any that are missing and shall maintain all markings in good condition. Supervisors shall discuss electrical safety with appropriate crew members at tailgate safety talks.

Spotters shall be positioned at the paver or widener to direct truck movement and observe for overhead wires. The spotter, drivers, operators, supervisors and all employees shall be alert for overhead wires.

All trucks operating on the project, delivering materials, or delivering equipment to the site shall display warning decals regarding electrical contact. Independent truck drivers delivering materials or equipment shall be provided decals. Drivers shall be told about the presence and location of overhead electrical wires before beginning work, how they are marked, and the requirements for spotters. Trucks that have emptied their material shall not leave the paver until the box is in its full down position.

2. Aerial Lifts, Cranes, Boom Devices. Where there is potential for proximity or contact with energized lines or equipment, work shall not begin until a safety meeting is conducted and appropriate steps are taken to identify, mark and warn against accidental contact. The supervisor shall review operations daily to ensure compliance.

Where the operator's visibility is impaired, spotters shall guide the operator. Hand signals shall be used and their meaning clearly understood between operator and spotter. When visual contact between the spotter and the operator is impaired, the spotter and operator shall be in two-way radio contact.

Aerial lifts, cranes, and boom devices shall be appropriate warning decals.

3. Tree Work. Wires shall be treated as live and high voltage until verified by the utility. Branches touching wires shall be removed by the utility before work begins. Limbs and branches shall not be dropped onto overhead wires. If limbs or branches fall across electrical wires, all work shall stop immediately and the utility shall be called.

When climbing or working in trees, pruners shall try to position themselves so that the trunks of the limbs are between their bodies and electrical wires. Pruners shall not work with their backs toward electrical wires. A bucket truck is the preferred method of pruning when climbing poses a greater electrical contact threat.

Personal protective gear shall have appropriate de-electric characteristics needed for working near electricity.

## SPECIAL NOTE ELECTRICAL SAFETY

### **UNDERGROUND ELECTRICAL LINES AND EQUIPMENT**

Before installation, excavation or subsurface exploration where there exists reasonable possibility of contracting any utility lines or equipment, the Underground Facilities Protective Organization (UFPO) shall be called and a request made for identifying/marketing their location(s).

When UFPO is called, telephone operators will need:

- minimum of two (2) working days notice prior to work beginning,
- name of County, City, Village or Town,
- name and number of street or highway marker,
- nearest intersection at work site,
- type of work,
- date and time work is to begin,
- caller's name, Contractor/Department name and address,
- phone number of contact and special instructions.

Utilities that do not belong to UFPO (udigny – 811) must be contacted separately. UFPO may not have a complete list of utility owners. The Village is required to maintain this information and may have to be contacted.

Utilities discovered shall be marked before work begins. Supervisors shall periodically refer their location to all workers who are subject to exposure, including new employees.

### **EMERGENCY RESPONSE**

When working near electrical lines or equipment, avoid direct or indirect contact. Direct contact is contact with any part of the body. Indirect contact occurs when part of the body touches or is in dangerous proximity to any object in contact with energized electrical equipment. Two assumptions should always be made: 1) that lines are “live” (energized); and 2) carry high voltage. Electrical lines can only be considered “dead” when verified by the utility.

When there is any question about voltage and safe distance, the owner of the lines or equipment must be called in advance of work. As voltages increase, minimum clearances increase. Through arcing, injuries or fatalities may occur even if actual contact with high voltage lines or equipment is not made. Potential for arcing increases as voltage increases. Weather and contact with conductors, such as tools, can increase the possibility of becoming energized without contact.

If an individual becomes energized, **DO NOT TOUCH** the individual or anything in contact with the person. Call for emergency medical assistance and the utility immediately. If the person is no longer in contact, CPR, rescue breathing or first aid should be administered immediately, but only by a trained person. It is safe to touch the victim once contact is broken or the source de-energized.

If the power line falls:

- keep everyone at least 10 feet (3,048mm) away,
- use flagging to protect motorists from fallen or low wires,
- call the utility, police or fire department immediately,
- place “guards” around the area,

**SPECIAL NOTE**  
**ELECTRICAL SAFETY**

- do not attempt to move the wire(s),
- do not touch anything that is touching the wire(s).
- be alert to water or other conductors present.

Wires that contact vehicles or equipment will cause arcing, smoke, and possible fire. Occupants should remain in the cab and wait for the utility. If necessary to jump from a vehicle, leap with both feet as far away from the vehicle as possible, without touching the equipment. Jumping free of the vehicle is the last resort.

Crews shall have emergency numbers readily available. These numbers shall include local utility, police/fire and medical assistance.

**SPECIAL NOTE**

**511 NY**

To assist in keeping the 511NY system up-to-date, any scheduled work or activities on local roads which restrict the width, height, length or weight availability of the travel way or shoulder, may be reported to the Surface Transportation Controller (STC) using the Road Work Form (RWF). The need to notify the STC shall be determined by the Engineer-in-Charge. All other lane closure notes and information in the contract documents shall also be followed.

**SPECIAL NOTE**

**RIGHT OF WAY**

All work to be performed under this contract will be within the public right-of-way (ROW) in accordance with section 105-15 of the standard specifications. The contractor is to assure themselves that all work is being performed within the ROW, including but not limited to vehicle access; storage or equipment, materials, debris and waste; landscaping; vegetation removal and management; grading, seeding and the installation of turf; and the installation of any fences or protective barrier.

If contractor is unable to identify the limits of the right-of-way when the contract calls for work in those vicinities, the contractor must contact the project engineer for definitive boundary determination before any work may be initiated at those location (standard specification sections 105-10 and 625).

In accordance with section 107-13 of the standard specifications, releases for any non-essential contract work outside of the existing right-of-way, including plantings, landscaping or driveway enhancement, will be provided by the project engineer and in no instance are to be secured by the contractor. The contractor shall not invade upon private properties, lands or buildings outside of the right-of-way for any reason without first securing written permission from the property owner (standard specifications sections 105-15, 107-13).

The contractor will be held liable for any damages done. Any such injuries or damages shall be satisfactorily repaired or items replaced at the contractor's expense (standard specifications section 107-08 and 107-13).

**SPECIAL NOTES**  
**QA FOR PROJECTS ON THE STATE OR NATIONAL HIGHWAY SYSTEM**

1. The contractor understands and agrees the inspection and approval of materials to be used on this project will be performed by a representative of the Village of Nyack.
2. When the contractor receives direction from a representative of the Village regarding the approval/rejection of materials such as hot mix asphalt, Portland cement concrete, structural steel, concrete structural elements and/or components, the contractor understands the decision is final and will accept it as such.
3. The contractor will not allow off-site materials subject to the inspection and approval of a Village representative to be shipped to the project site prior to receiving authorization from a representative of the Village.
4. As soon after award as practicable, and prior to the pre-construction conference, the contractor shall provide the following information to the Sponsor and NYSDOT Regional Local Project Liaison.
  - A. The name and address of each manufacturer of all materials and portions thereof requiring off-site quality assurance in accordance with NYSDOT's specifications to be used in this project.
  - B. The name and address of each fabricator fabricating structural steel items or any portion thereof to be used in this project.
  - C. The name and address of each fabricator manufacturing structural concrete items or any portion thereof to be used in this project.
5. The contractor agrees that it and its subcontractors and suppliers will only acquire materials for this project through NYSDOT-approved manufacturing, batching and fabrication facilities.

**SPECIAL SPECIFICATIONS:**

The following items are special specifications:

<b>SPECIAL SPECIFICATIONS</b>	
<b>ITEM NUMBER</b>	<b>DESCRIPTION</b>
420.98010104	POROUS PAVEMENT
559.91100010	ANTI-GRAFFITI PROTECTIVE COATING
601.04030011	METHYL METHACRYLATE SURFACE TREATMENT - GREEN
606.31120010	SINGLE SLOPE FULL SECTION CONCRETE BARRIER WITH STONE PATTERN
607.91120001	STEEL RAILING AND HANDRAIL
608.01020005	COLORED AND IMPRINTED PCC SIDEWALK
608.21000003	CAST IRON DETECTABLE WARNING UNIT
611.19010024	POST PLANTING CARE WITH REPLACEMENT - MAJOR DECIDUOUS TREES
615.08010005	BENCH TYPE 01
615.92010011	PRECAST CONCRETE STEPS (STRAIGHT)
627.50140008	CUTTING PAVEMENT
640.25000010	BLUE REFLECTORIZED PAVEMENT MARKINGS
645.73000001	ORNAMENTAL SIGN
645.81090003	RETROREFLECTIVE SIGN POST STRIP
647.83001002	REMOVAL AND DISPOSAL OF DELINEATORS
655.05010010	RESETTING EXISTING SANITARY SEWER MANHOLE CASTINGS
655.07010010	CAST FRAME F2 WO CURB BOX
660.65000101	ALTERING UTILITY MANHOLES AND VAULTS
670.03020011	RELOCATE LAMPPOST ASSEMBLY
670.14480010	RESETTING ELECTRIC PULLBOX COVERS AND FRAMES
670.15010005	FURNISH AND INSTALL DECORATIVE LIGHT POLE ASSEMBLY
670.53070104	POWER POINT DISCONNECT ASSEMBLY
680.510X0009	ALTER ELEVATION OF PULLBOX TYPE 2 AND TYPE 3
680.77000X05	MODIFY TRAFFIC INSTALLATION
680.51100010	CLEAN EXISTING PULLBOX
680.78010005	ALTER PULLBOX FOR CONDUITS
680.82250101	REMOVE PEDESTRIAN PUSHBUTTON AND SIGN ASSEMBLY
680.82250108	REMOVE AND DISPOSE PEDESTRIAN POLE AND FOUNDATION
680.82250201	REMOVE PEDESTRIAN SIGNAL ASSEMBLIES
680.82252110	RRFB
680.90920008	ELECTRIC METER SOCKET 200 AMP FOR SIGNALS
680.93510008	GPS TIME SYNCHRONIZATION ANTENNA AND INTERFACE MODULE

**ITEM 420.9801NN04 – POROUS PAVING SURFACE PRODUCT, TYPE NN**

**DESCRIPTION**

This work shall consist of furnishing and installing a porous paving surface product in accordance with these specifications, as shown on the contract documents and as directed by the Engineer.

All information indicated in this specification as being "...as specified in the contract documents" will be contained in either a special note(s) (in the contract proposal) or note(s) (on the contract plans) titled, *Porous Paving Surface Product*.

**MATERIALS**

The following ASTM specifications shall apply:

Standard Test Method for Static Coefficient of Friction of Polished-Coated Flooring Surfaces as Measured by the James Machine	D2047
Standard Test Method for Infiltration Rate of In Place Pervious Concrete	C1701

Porous Paving Surface – The porous paving product shall consist of recycled rubber granules and/or aggregate, bonded to create a porous paving surface. The recycled rubber granules and aggregate shall be per manufacturer’s specifications.

The porous paving surface shall be from one of the following manufacturers:

KBI Flexi-Pave HD200  
as manufactured by  
Atlantic Power and Infrastructure  
4600 140<sup>th</sup> Avenue N., Suite 200  
Clearwater, FL 33762  
727.723.3300  
<https://apaicorp.com/kbi.htm>

Porous Pave XL  
as manufactured by  
Porous Pave Inc.  
4385 East 110<sup>th</sup> Street  
Grant, MI 49327  
888.448.3873; 231.834.7720  
[porouspaveinc.com](http://porouspaveinc.com)

perkEpave  
as manufactured by  
perkEpave, LLC  
418 Wilson Street  
Pottstown, PA 19464  
215.316.6383  
[www.perkEpave.com](http://www.perkEpave.com)

or equal as approved by the Engineer

The slip resistance, when measured in accordance with ASTM D2047, shall have a coefficient of friction greater than or equal to 0.6.

Color – Color shall be as specified in the contract documents.

Pavement Thickness – The minimum product thickness shall be as shown in the contract documents.



## **ITEM 420.9801NN04 – POROUS PAVING SURFACE PRODUCT, TYPE NN**

### **CONSTRUCTION DETAILS**

#### **Submittals**

At least two (2) weeks prior to the placement of the test panel, the Contractor shall submit the following for approval:

- porous paving surface mix design,
- slip resistance test results,
- manufacturer's installation guidelines,
- equipment list, and
- installers certification and manufacturer's verification.

Color samples shall be submitted for approval two (2) **months** prior to installation of the test panel.

**Equipment** – All equipment, tools, machinery, and other appliances used in handling materials and executing any part of the work shall be subject to approval before the work begins.

**Installers** – If required by the manufacturer, the porous paving surface must be installed by a certified installer, certified by the manufacturer to install the product. The installer shall provide proof of certification and the manufacturer's verification. All methods of construction, and workmanship shall conform to applicable requirements, unless otherwise specified.

**Test Panel** – A test panel must be constructed, at no additional cost to the State, as described below.

At least one week prior to the placement of the permanent panels, the Contractor shall prepare the subgrade, place, joint (if required), cure, and finish a test panel. The test panel shall be at least 9 sq. ft. in size, constructed at the required thickness. The test panel will:

- be constructed at a pre-designated location,
- remain in place for the duration of the project, and
- be used as a reference for acceptance of the pavement surface.

The test panel must be tested in accordance with ASTM C1701. The test panel must have a minimum infiltration rate of 210 inches per hour. If the test panel does not meet this performance criterion, it shall be removed and redone at the Contractor's expense, and the failed test panel disposed of in an appropriate manner.

The test panel may be incorporated into the final work or may be removed when ordered.

#### **Surface Preparation**

The subgrade shall have all foreign material removed and be compacted to an even surface that is parallel to the finish grade of the porous paving surface or as directed. Contact surfaces of curbing, sidewalks, manholes, and other structures shall be coated with a thin uniform coating of the manufacturer's formulated polyurethane binding agent, or approved equivalent, prior to placing the porous paving surface against them.

## **ITEM 420.9801NN04 – POROUS PAVING SURFACE PRODUCT, TYPE NN**

The Contractor shall provide appropriate and adequate protection of adjacent surfaces from splashing of paving materials. Remove all stains from exposed surfaces of paving, structures, and grounds. Remove all waste and spillage.

The Contractor shall, where required, provide appropriate, adequate, and suitable protection to assure no damage or disturbance to existing infrastructure – including vegetation – before starting work and maintain that protection throughout the course of the work.

### **Installation**

Typical porous paving surface can be installed when the surface temperatures of the subgrade is 50°F or above, but not over 95°F. Refer to manufacturer's instructions on subgrade temperature and moisture content.

The Contractor shall not pave on days when the weather is foggy, or rain is forecast, unless a change in the weather results in favorable paving conditions.

Product shall be installed per the manufacturer's recommendations.

During installation and compaction of subbase materials, grade and drainage conditions should be considered and evaluated in the field to avoid over-compaction or the creation of areas of potential ponding.

The spreading and finishing of adjacent strips of the porous paving surface shall proceed so that the full pavement width will be completed in one 'pour' without the formation of longitudinal joints.

The porous paving surface finish shall be smooth and true to the existing or required grade(s).

### **Post Installation**

Traffic on the product shall be restricted for at least 24 hours after installation or as required by the product manufacturer.

The Contractor shall restore damaged adjacent infrastructure (including vegetation) to their original condition or repair as directed at no additional cost to the state. This includes existing pavement on, or adjacent to, the installation site damaged because of the construction work.

If the porous paving surface becomes plugged with dirt or defective (in any other way) during construction, the porous paving surface shall be removed and replaced at no additional cost to the State. Any porous paving surface that becomes loose and broken prior to final contract closeout shall also be removed and replaced by the Contractor, at no additional cost to the owner.

### **METHOD OF MEASUREMENT**

The work will be measured as the number of square feet of porous paving surface installed.

**ITEM 420.9801NN04 – POROUS PAVING SURFACE PRODUCT, TYPE NN**

**BASIS OF PAYMENT**

The unit bid price per square foot of porous paving surface furnished and installed shall include the cost of all labor, materials, and equipment necessary to satisfactorily complete the work.

No direct payment will be made for any losses of material which may result from shrinkage, compaction, settlement, waste, overflow, or any other causes.

Excavation, furnishing and placement of subbase course materials (aggregate and geotextile) shall be paid for under separate payment items.

***Payment will be made under:***

<b>Item Number</b>	<b>Item Description</b>	<b>Unit</b>
420.9801NN04	Porous Paving Surface Product	SF

Where:

NN = A serialization pay item number for each unique color of porous paving surface installed.

## **ITEM 554.6000XX02 - STAIRWAY FOR FILL TYPE RETAINING WALL**

### **DESCRIPTION**

Under these items the Contractor shall furnish and install a stairway, consisting of precast or drycast concrete stairway and landings units, designed to provide access from the top to the bottom of a fill type retaining wall as shown in the contract documents. The precast or drycast concrete stairway and landings units shall meet the type and appearance of the selected fill type retaining wall.

### **MATERIALS**

Materials for this work shall meet the requirements of Standard Specifications §554-2 *Materials*.

### **CONSTRUCTION DETAILS**

The Contractor shall be responsible to submit an acceptable design for the stairway erection.

#### **Submittal**

Select a designer appearing on the Approved List for Fill Type Retaining Walls. The Contractor is responsible to ascertain which wall system designers provide designs and details for stairways that can be incorporated into the Fill Type Retaining Wall.

Obtain from the chosen designer a Fill Type Retaining Wall design stamped by a Professional Engineer. Submit the design package, including working drawings of the wall design, design calculations, and the designers Installation Manual in accordance with the requirements of Standard Specifications §554-3.01 B. *Fill Type Retaining Wall Submittal*.

#### **Installation**

Install the stairway units in accordance with the designer's approved shop drawings and Installation Manual, unless otherwise modified by the contract documents. Prior to installation of the stairway units, furnish the Engineer with detailed information concerning the proposed construction method, as well as the equipment planned for use.

Install by placing, positioning, and aligning stairway units in conformance with the designers Installation Manual. All stairway units shall be assembled and handled in accordance with the designer's instructions and the contract documents. Erect the stairway conforming to the lines, grades, and typical sections shown on the contract documents and in accordance with the designated manufacturer's installation manual. During erection, any stairway unit damaged beyond repair shall be removed and replaced by the Contractor with approved stairway units at no additional cost to the State.

For stairway units requiring unit infill, place unit infill to the limits indicated in the approved shop drawings. Before installing the next course of stairway units, compact the unit infill and brush the tops of the stairway units clean to ensure an even placement area. Protect unit infill from contamination during construction.

For installations requiring backfill between the stairway units and the fill type retaining wall, place and compact backfill and stairway unit infill simultaneously and in accordance with

**ITEM 554.6000XX02 - STAIRWAY FOR FILL TYPE RETAINING WALL**

*Compaction* in Section 203 Excavation and Embankment. Placement of stairway unit infill and backfill behind the units shall closely follow the erection of successive courses of stairway units.

Ensure the stairway is integral with or properly connected to the fill type retaining wall.

**METHOD OF MEASUREMENT**

This work shall be measured by the number of stairways furnished and installed in accordance with the contract documents.

**BASIS OF PAYMENT**

The unit price bid for furnishing and installing a stairway of precast or drycast concrete stairway units shall include the cost of furnishing all labor, materials and equipment necessary to satisfactorily complete the work.

Note: XX denotes serialized pay item, see §101-02 Definition of Terms, *Contract Pay Item*. The State will make payment for each stairway based on required access, i.e. height of the fill type retaining wall.

Payment will be made under:

<b>Item No.</b>	<b>Item</b>	<b>Pay Unit</b>
554.60000102	Stairway for Fill Type Retaining Wall (0 – 6 ft.)	Each
554.60000202	Stairway for Fill Type Retaining Wall (Greater than 6 ft. – 12 ft.)	Each
554.60000302	Stairway for Fill Type Retaining Wall (Greater than 12 ft. – 18 ft.)	Each
554.60000402	Stairway for Fill Type Retaining Wall (Greater than 18 ft. – 24 ft.)	Each
554.60000502	Stairway for Fill Type Retaining Wall (Greater than 24 ft. – 30 ft.)	Each
554.60000602	Stairway for Fill Type Retaining Wall (Greater than 30 ft.)	Each

## **ITEM 559.91100010 - ANTI-GRAFFITI PROTECTIVE COATING**

### **DESCRIPTION**

Under this item, the Contractor shall clean, furnish and place anti-graffiti protective coating on noise barrier walls, retaining walls, bridge structures, barriers, or other concrete surfaces at locations indicated in the contract documents or approved by the EIC. Wood surfaces shall not be treated with anti-graffiti protective coating under this item.

The Contractor shall apply the protective coating on selected surfaces within the limits in the contract documents. In addition, the Engineer may order that certain areas receive increased coverage or new locations be added.

### **MATERIALS**

The protective coating shall be a breathable, one component clear non-sacrificial urethane or acrylic water based formulation designed as an anti-graffiti solution.

The Contractor shall provide the manufacturer's product literature including surface preparation data, mixing, application, spread rates, storage and Volatile Organic Compounds (VOC) compliance certification.

All materials are to be approved by the Engineer and the Regional Landscape Architect before any work can begin.

### **CONSTRUCTION DETAILS**

1. The selected surfaces shall be thoroughly cleaned of dust, dirt, grease, oil, loose materials or other objectionable materials before applying the protective coating. No sandblasting will be allowed. Anti-graffiti coating shall be applied as soon as practicable after cleaning is completed. If in the opinion of the Engineer, the surface has become soiled, or otherwise contaminated, prior to the application of the protective coating; the surface shall be re-cleaned at no additional cost to the State.
2. Surface and material temperatures shall be a minimum of 40° F or as recommended by the manufacturer.
3. Material shall be applied by brush, roller or low-pressure spray. The rolling shall be done only on smooth surfaces and at such a pace that no spinning of the roller or throwing off of protective coating material occurs when the roller is lifted from the surface. Coverage rate shall be as recommended by the manufacturer and as approved by the Engineer.
4. The protective coating shall be applied in a uniform manner to evenly coat all pores and textured areas. Extremely textured or porous surfaces will require a second coat. Unless otherwise designated by the Engineer, the protective coating shall be applied from

## **ITEM 559.91100010 - ANTI-GRAFFITI PROTECTIVE COATING**

column to column, post to post, and from bottom to a height of 8 feet 2.5 for noise barrier wall panels, and from joint to joint or scoremark to scoremark and from bottom to a height of 8 feet for abutments, walls or other surfaces.

5. Avoid high wind and rain, prolonged exposure in summer sunlight, and keep from freezing 12 hours after application.
6. A test panel 5 foot x 5 foot shall be provided and coated to insure suitability, number of coats required, and desired results. The test panel application and results shall be inspected and approved by the Engineer and the Regional Landscape Architect.
7. All work must conform to the OSHA standards referred to in subsection 107-05 of the Standard Specifications.
8. No dilution can happen of dilution or cleaner.

### **METHOD OF MEASUREMENT**

This work will be measured by the number of square feet of surface covered with the anti-graffiti coating applied, in accordance with this specification. Test panels prepared under this item will not be measured for payment.

### **BASIS OF PAYMENT**

The unit price bid per square foot shall include the cost of furnishing all labor, materials and equipment necessary to prepare the surfaces and apply the coating in accordance with the contract documents and as directed by the Engineer. The cost of providing necessary test panels shall also be included in the price bid for this item.

## **ITEM 560.12010010 – SEAT WALL**

### **DESCRIPTION**

Under this item the Contractor shall furnish and install Seat Walls of the size and at the locations shown in the contract documents and as directed by the Engineer.

### **MATERIALS**

- Concrete for footing and core shall be Class A, conforming to Section 501.
- Portland Cement - Type 1 or Type 2, conforming to Section 701-01.
- Masonry Cement, conforming to Section 701-02.
- Fine Aggregates, conforming to Section 703-01.
- Coarse Aggregates, conforming to Section 703-02.
- Mortar Sand, conforming to Section 703-03.
- Masonry Mortar, conforming to Section 705-21.
- Epoxy Coated Bar Reinforcement, Grade 60, conforming to Section 709-04.
- Bluestone cap shall conform to Dimensional Masonry, Section 560-2.01.
- Manufactured Masonry Veneer shall match base of adjacent Taste NY building as follows:
  - A. Profile: Drystack. Include matching corner pieces.
  - B. Stone Accents:
    - 1. Color: To match main building. To be selected from the manufacturer's full range of material styles and colors.
    - 2. Texture: To match main building. To be selected from the manufacturer's full range of material styles.
  - C. Veneer Unit properties: Precast veneer units consisting of Portland cement, lightweight aggregates, and mineral oxide pigments.
  - D. Compressive Strength: ASTM C 192 and ASTM C 39, 5 sample average: greater than 1,800 psi (12.4MPa).
  - E. Shear Bond: ASTM C 482: 50 psi (345kPa), minimum.
  - F. Freeze-Thaw Test: ASTM C 67: Less than 3 percent weight loss and no disintegration.
  - G. Thermal Resistance: ASTM C 177: 0.473 at 1.387 inches thick.
  - H. Weight per square foot: 2012 IBC and 2012 IRC, ASTM C1670, 15 pounds, saturated
  - I. Manufacturer:
    - 1. Eldorado Stone, LLC  
1370 Grand Ave., Bldg. B  
San Marcos, CA 92069  
[www.eldoradostone.com](http://www.eldoradostone.com)



## **ITEM 560.12010010 – SEAT WALL**

2. Boral Stone Products LLC  
One Owens Corning Parkway  
Toledo, OH 43659 [www.culturedstone.com](http://www.culturedstone.com)
3. Quality Stone Veneer Inc.  
50 Refton Road  
Refton, PA 17568  
[info@qualitystoneveneer.com](mailto:info@qualitystoneveneer.com)

### **CONSTRUCTION DETAILS**

The Contractor shall perform all work necessary to construct seat walls at the locations shown on the Plans and as shown in the Details. Excavation shall be performed in accordance with Section 206 of the Standard Specifications. Masonry work shall comply with Section 560 of the Standard Specifications. Concrete for foundation and core shall meet the requirements for Class A concrete for structures as specified in Section 501.

General: No masonry shall be constructed when the ambient temperature is 40° F or below, or when any masonry unit exhibits frost, except by written permission of the Engineer and subject to any conditions he may require.

Masonry units shall not be dropped upon or slid over existing masonry, nor shall hammering or turning of masonry units on the existing masonry be allowed. Masonry units shall be carefully set without jarring masonry already laid, and they shall be handled in a manner so as not to cause disfigurement.

Protection and Handling: Upon delivery to the site, the masonry units shall be neatly piled off the ground, on pallets or other approved implements, and protected from moisture by wrapping them with 4 mil polyethylene. Masonry units which become wet shall be permitted to dry for at least seven days before being laid in the wall.

Laying: The manufactured masonry veneer masonry shall be laid up, in the pattern shown on the plans, by skilled masons and in first-class manner. The masonry shall be laid true to line and grade in level horizontal beds and be properly anchored. Each masonry unit shall be laid in a full mortar bed and in a manner to form a full end joint in one operation. The space between the masonry veneer and the adjacent concrete core shall be filled with mortar as each unit is placed.

### **METHOD OF MEASUREMENT**

The work will be measured as the number of linear feet of seat wall, measured along the center line of the top of the wall, furnished and erected in accordance with the contract documents.

**ITEM 560.12010010 – SEAT WALL**

**BASIS OF PAYMENT**

The unit price bid per linear foot of seat wall shall include the cost of furnishing all labor, materials, tools, and equipment necessary to satisfactorily complete the work for each sign. Excavation, concrete footing, masonry work and installation and disposal of excess materials and backfilling are all included in this item.

**601.040X0011– Methyl Methacrylate Color Surface Treatment (MMA-CST)**

**DESCRIPTION**

The work consists of furnishing and applying an MMA-CST at the location indicated in, and in accordance with, the contract documents and as ordered by the Engineer.

**MATERIALS**

The MMA-CST shall be capable of application on new and existing asphalt and Portland cement concrete surfaces, and shall:

- Be VOC compliant and lead chromate free.
- Not contain 0.1% or more of any chemical listed by the International Agency for Research on Cancer (IARC), the National Toxicology Program (NTP), or regulated by the US Occupational Safety and Health Administration (OSHA) as a carcinogen.
- Conform to current Federal, State and Local air pollution regulations, including those for the control (emission) of volatile organic compounds (VOC).
- Be packaged and stored in accordance with the manufacturer’s instructions and requirements for shelf life and storage conditions in original unopened containers. Shipping documents and containers shall have identification numbers or batch dates for confirmation of when products were manufactured, clearly labeled as to the type of material and the ratio of the components to be mixed by volume as well as showing resin or hardener components, brand name, name of manufacturer, lot or batch number, temperature range for storage, expiration date and the quantity contained. Include any special instructions regarding mixing and the Material Safety Data Sheets. This information shall be made available for inspection at any time.
- Color selection shall meet the color requirements below:

Colored green for bicycle lanes, meeting the color requirements below:

<b>GREEN:</b>							
Daytime chromaticity coordinates							
1		2		3		4	
X	y	x	y	x	y	x	y
0.230	0.754	0.266	0.460	0.367	0.480	0.444	0.583

Daytime luminance factor (Y) shall be at least 7, but no more than 35.

Colored red for bus lanes, meeting the color requirements below:

<b>RED:</b>							
Daytime chromaticity coordinates							
1		2		3		4	
x	y	x	y	x	y	x	y
0.420	0.330	0.450	0.380	0.560	0.370	0.540	0.320

other colors are specified in the Contract Documents for other applications.

- Incorporate aggregates compatible approved by the MMA manufacture for compatibility and handling in compliance with manufacturer recommendations – providing a surface friction level equivalent or better than existing pavement.

## **601.040X0011– Methyl Methacrylate Color Surface Treatment (MMA-CST)**

**APPROVED MATERIALS.** Products appearing on the list below with a Manufacturer’s certification that the product meets the requirements of this specification, or a Product approved equal as determined by the Engineer, are deemed acceptable for use:

Color-Safe®  
Transpo Industries, Inc.  
20 Jones Street  
New Rochelle, NY 10801  
800-321-7870  
[www.transpo.com](http://www.transpo.com)

MMA®  
Ennis-Flint  
115 Todd Court  
Thomasville, NC 27360  
336-475-6600  
[www.ennisflint.com](http://www.ennisflint.com)

Safetrack®SC  
GCP Applied Technologies, Inc.  
2325 Lakeview Parkway  
Alpharetta, GA 30009  
<https://gcpat.com>

or equal as approved by the Engineer.

### **CONSTRUCTION DETAILS**

**General.** MMA-CST shall be placed as shown on the contract or work order documents.

- Before any surface treatment work is begun, a schedule of operations shall be submitted for the approval. At least five (5) days prior to starting application, the Contractor shall provide the MMA color manufacturer's written instructions for use. These instructions shall include, but not be limited to, material mixing ratios and application temperatures.
- When MMA-CST is applied under traffic, the Contractor shall provide all necessary flags, markers, signs, etc. in accordance with the MUTCD to maintain and protect traffic, and to protect marking operations and the markings until thoroughly set.
- The Contractor shall be responsible for removing, to the satisfaction of the Engineer, all tracking marks, spilled MMA-CST applied in unauthorized areas.

**Atmospheric Conditions.** MMA-CST shall only be applied during conditions of dry weather and on dry pavement surfaces. At the time of installation, the pavement surface temperature shall be at or above manufacturer recommendations.

**Surface Preparation.** The Contractor shall clean the pavement and existing durable markings according to manufacturer’s recommendations and to the satisfaction of the Engineer. At the time of application, all pavement surfaces and existing durable markings shall be free of oil, dirt, dust, grease, and similar foreign materials.

**Application Equipment.** Equipment for the placement of MMA-CST shall be approved prior to the start of work. Application equipment shall include:

1. Squeegees designed for heavy duty use (3/16” notched)
2. Rollers that are medium nap in texture and contain a roller cage and handle

## **601.040X0011– Methyl Methacrylate Color Surface Treatment (MMA-CST)**

3. High speed, high torque drills capable of supplying enough power to thoroughly mix MMA-CST additives when paired with a paint mixing paddle

**Application.** MMA-CST shall be placed at the width, thickness, and pattern designated in the contract documents. Surface treatment operations shall not begin until applicable surface preparation work is completed and approved, and the atmospheric conditions and pavement surface temperature are acceptable.

If recommended by the MMA-CST manufacturer, a primer shall be applied to the surfaces where the MMA-CST is to be installed.

MMA-CST shall be poured onto pavement and evenly distributed using a squeegee. The applied film thickness shall be about 95 +/- 5 mils (based on manufacturers recommendations). Trowels may be used in cases where squeegees are not effective. Rollers should then be used to distribute MMA-CST, remove working lines, and create a consistent anti-slip texture. Masking tape or similar should be removed as material gels, but before it cures. If required by manufacturer, all concrete surface areas to be coated with MMA-CST shall be masked with primer prior to MMA-CST application.

**Defective Results.** MMA-CST, which after application and curing is determined to be defective and not in conformance with this specification, shall be repaired. Repair of defective MMA-CST shall be the responsibility of the Contractor and shall be performed as follows:

1. Insufficient film thickness:

Repair Method.

- Prepare the surface of the MMA-CST to the satisfaction of the Engineer.
- Repair shall be made by reapplying MMA-CST over the cleaned surface in accordance with the requirements of this specification at the full thickness.

2. Uncured or discolored MMA-CST and/or insufficient bond (to pavement surface or existing durable marking):

Repair Method. The defective MMA-CST shall be completely removed and cleaned to the underlying pavement surface.

After surface preparation work is complete, repair shall be made by reapplying MMA color over the cleaned pavement surface in accordance with the requirements of this specification.

Other defects not noted above but determined to need repair, shall be repaired, or replaced.

All work in conjunction with the repair or replacement of defective MMA color shall be performed at the Contractor's expense.

**Personal Protective Equipment.** Follow all exposure, respiratory and personal protective equipment controls, handling and safety precautions and spill and disposal procedures as identified by safety data sheets (SDS), labels and other manufacturer's recommendations for the products used.

**601.040X0011– Methyl Methacrylate Color Surface Treatment (MMA-CST)**

**WORK ZONE TRAFFIC CONTROL (WZTC).** The Contractor is responsible for ensuring appropriate WZTC in compliance with the MUTCD appropriate for the dry time of the selected material applied. The Contractor is responsible to ensure adequate WZTC to prevent those walking, skating, bicycling, and driving from meeting applied material that is still capable of being tracked. The Contractor shall be liable for such tracking and property damage should it occur.

**METHOD OF MEASUREMENT**

The work will measure in square feet, computed within the payment lines shown on the contract documents or otherwise ordered, of methyl methacrylate color surface treatment installed.

**BASIS OF PAYMENT**

The unit bid price per square foot of all methyl methacrylate color surface treatment shall include the cost of furnishing all labor, materials, and equipment necessary to satisfactorily complete the work.

**Payment will be made under:**

Item No.	Item Description	Pay Unit
601.04030011	Methyl Methacrylate Color Surface Treatment for Pavements (MMA-CST) - Green for Bicycle Facilities	Square Foot
601.04040011	Methyl Methacrylate Color Surface Treatment for Pavements (MMA-CST) - Red for Bus Lanes and Pull-Offs	Square Foot
601.04050011	Methyl Methacrylate Color Surface Treatment for Pavements (MMA-CST) - Other Colors for Miscellaneous Applications	Square Foot

**606.31120010 – SINGLE SLOPE FULL SECTION CONCRETE BARRIER CAST WITH SIMULATED STONE PATTERN FINISH (PRECAST)**

**606.31130010 - SINGLE SLOPE HALF SECTION CONCRETE BARRIER CAST WITH SIMULATED STONE PATTERN FINISH (PRECAST)**

**DESCRIPTION:**

This work shall consist of furnishing and installing a single slope full or half section precast concrete barrier cast with a simulated stone pattern finish as indicated in the contract documents and as directed by the Engineer.

**MATERIALS:**

The following sections of the standard specifications shall apply:

Concrete Barrier	606-2
Precast Concrete – General	704-03

The following ASTM references shall apply:

Standard Practice for Determination of the Effectiveness of Anti-Graffiti Coating for use on Concrete, Masonry and Natural Stone Surfaces by Pressure Washing	ASTM D7089
---------------------------------------------------------------------------------------------------------------------------------------------------------------	------------

**Precast Concrete Barrier** (additional information): The precast concrete barrier unit shall:

- consist of precast concrete per §704-03,
- be integrally colored by use of a “color pigment additive” per §704-03 C. (color as shown on the contract documents), and
- include a stone pattern facing (hereafter, “pattern”) of the type, dimensions, and/or finish shown in the contract documents. This pattern shall comply with §704-03 A and be placed on the road side face of both the full and half section barrier. The application of the pattern shall not compromise the required minimum concrete cover over reinforcing steel at any point as shown in the contract documents.

Each precast concrete barrier unit shall consist of three form liner segments. Each form liner segment shall have different configurations of “stones” to create a random masonry pattern. All three form liner segments shall be able to interlock with each other. The Contractor shall fabricate at least three distinct precast concrete barrier units, each with a different sequence of form liner segments.

Surface Finish Guidelines:

1. Textures added after formlined casting, if specified, shall have a maximum relief of a third of an inch.
2. All form lined “mortar joints” and any other gaps, slots or grooves shall be less than a half an inch in depth and one inch in width.

**606.31120010 – SINGLE SLOPE FULL SECTION CONCRETE BARRIER CAST WITH SIMULATED STONE PATTERN FINISH (PRECAST)**

**606.31130010 – SINGLE SLOPE HALF SECTION CONCRETE BARRIER CAST WITH SIMULATED STONE PATTERN FINISH (PRECAST)**

3. Any pattern shall have a maximum relief of three quarters of an inch over a distance of one foot.
4. For any pattern that begins two feet or higher above the base of the precast concrete barrier, the maximum relief shall be two and one half inches. No part of the pattern shall protrude beyond the projected surface plane of the lower two feet of the precast concrete barrier.
5. Regardless of where the patterning begins, all the leading edges of the precast concrete barrier units shall be rounded or sloped to minimize the potential for vehicle snagging.

The precast concrete barrier units shall be nominal 20.0 ft. in length to the greatest extent possible to provide a homogeneous appearance. At locations where unit lengths required are not equal to 20.0 feet, the Contractor shall adjust the form liner patterning so that a homogeneous appearance is maintained.

**Anti-Graffiti Protective Coating:** The protective coating shall be:

- tested according to ASTM D7089 and capable of achieving a rating of “Cleanability Level 1” after cleaning,
- non-sacrificial (permanent),
- applied at the precast manufacturer, no anti-graffiti coating shall be field applied, and
- applied according to manufacturer’s instructions.

**Submittals – Fabrication Drawings and Samples:**

The Contractor shall provide fabrication drawings of the precast concrete barriers for approval. Fabrication drawings shall include:

- details showing the configuration of “stones” on each of the form liner segments proposed.
- details showing the placement of each form liner segment on the precast concrete barrier. The Contractor shall show at least three (3) different layouts of form liner segments on precast concrete barrier units.
- “Pattern layout plans” showing the placement of each precast concrete barrier unit at each discrete location. The Contractor’s “Pattern Layout Plan” shall verify that the layout of the precast concrete barriers will be done in a manner that maximizes a random appearance of the simulated stone. No identically patterned precast concrete barrier units shall be placed adjacent to each other.

The Contractor shall provide and assemble three 20.0 ft. samples of the precast concrete barrier at a designated location, for use as a visual standard. Each sample shall show a different configuration of the form liner segments. Additional precast concrete barrier shall not be constructed until the sample is approved in writing. Once approved, sample precast concrete barrier units shall be returned to the precast manufacturer and used as visual standards



**606.31120010 – SINGLE SLOPE FULL SECTION CONCRETE BARRIER CAST WITH SIMULATED STONE PATTERN FINISH (PRECAST)**

**606.31130010 – SINGLE SLOPE HALF SECTION CONCRETE BARRIER CAST WITH SIMULATED STONE PATTERN FINISH (PRECAST)**

throughout fabrication of subsequent units. The Contractor shall furnish and install precast concrete barrier conforming to approved visual standards.

**CONSTRUCTION DETAILS:**

The following sections of the standard specifications shall apply:

Trench, Culvert and Structure Excavation	206-3
Precast Concrete Barrier	606-3.05

**Inspection, Storage and Handling of Barrier Sections:**

The precast sections will be inspected at the installation site for the following:

- Damage during shipment
- Conformance to the material requirements
- Dimensional tolerances under §606-3.05 A. 3.

An additional inspection will be made prior to placement of the barrier sections to determine any damage during storage.

**Installation of Barrier Sections:**

**A. Excavation and Backfill.** The requirements specified in §206-3 Trench, Culvert and Structure Excavation, shall apply. The bottom of the barrier shall have a full and even bearing on the surface under it. After the barrier is in place, the excavation shall be backfilled in accordance with §206-3.04.

**B. Placement of Barrier.** Sections shall be installed to form a longitudinal barrier in accordance with §606-3.05A, true to line and grade on concrete leveling pads on prepared, compacted sub base, as specified in the contract plans. If required on plans, weep holes for drainage shall be provided.

The Contractor shall vary the order of the precast concrete barrier units so that the:

- proposed sequence of precast concrete barrier units at each location shall maximize a random appearance of the simulated stone, with no identical units adjacent to each other (“Pattern layout plans” shall be submitted for approval with the fabrication drawings as noted above).
- flow of joints from one form liner segment to the other or from one precast concrete barrier unit (consisting of three form liner segments) to the other does not appear unnatural.

**C. Half section barrier.** Half section concrete barrier shall be erected in accordance with §606-3.05A and with the appropriate continuity plates and back-up posts or earth back-up as shown on the standard sheets and in the contract documents.

**606.31120010 – SINGLE SLOPE FULL SECTION CONCRETE BARRIER CAST WITH SIMULATED STONE PATTERN FINISH (PRECAST)**

**606.31130010 – SINGLE SLOPE HALF SECTION CONCRETE BARRIER CAST WITH SIMULATED STONE PATTERN FINISH (PRECAST)**

**D. Joints.** Barrier sections shall be installed and sealed as per the details of the system. The Contractor shall use joint details provided by the manufacturer of the barrier and approved by the Department.

**METHOD OF MEASUREMENT:**

This work will be measured as the number of feet, to the nearest one third of a foot, of the Concrete Barrier Cast with Simulated Stone Pattern Finish (Precast) furnished and installed. The measurement will be taken along the centerline of top of the barrier. Measurement will not include any sample barrier sections not incorporated into the work.

**BASIS OF PAYMENT:**

The unit price bid for each foot of Concrete Barrier Cast with Simulated Stone Pattern Finish (Precast) furnished and installed shall include the cost of all labor, materials and equipment necessary to satisfactorily complete the work. Work includes excavation, grading, compaction, back up posts, continuity connections and anti-graffiti protective coating.

*Payment will be made under:*

<b>Item No.</b>	<b>Item</b>	<b>Pay Unit</b>
606.31120010	Single Slope Concrete Barrier Cast with Simulated Stone Pattern Finish (Precast)	FEET
606.31130010	Single Slope Half Section Concrete Barrier Cast with Simulated Stone Pattern Finish (Precast)	FEET

**ITEM 607.91120001 - STEEL RAILING AND HANDRAIL**

**DESCRIPTION:**

Under this work the Contractor shall furnish and install steel railing and handrail, including all necessary appurtenances as shown on the plans or indicated in the contract documents.

All work shall be in accordance with the plans in contract documents.

**MATERIALS:**

All materials shall conform to the plans.

**CONSTRUCTION DETAILS:**

All construction details shall conform to the plans in the contract documents

The steel railing and handrail shall be assembled and installed true to line and grade with posts vertical as shown on the plans or as directed by the Engineer.

The Contractor shall protect all parts of the steel railing and handrail and maintain it in an undamaged condition until completion and acceptance of the work. Any sections damaged at any time prior to final acceptance shall be repaired at the Contractors expense.

**METHOD OF MEASUREMENT:**

The quantity to be measured under this item shall be the number of linear feet of steel railing and handrail, including all appurtenances installed in accordance with the plans and directions of the Engineer.

**BASIS OF PAYMENT:**

The unit price bid shall include the cost of furnishing all materials, labor, and all equipment necessary to satisfactorily complete the work. This includes welding, painting and all other incidentals necessary to complete installation.

**608.010X0005 - COLORED AND IMPRINTED PORTLAND CEMENT CONCRETE  
SIDEWALK AND DRIVEWAYS**

**DESCRIPTION**

The work shall consist of furnishing and installing colored, imprinted, or colored and imprinted Portland cement concrete sidewalks as shown on the contract documents and as directed by the Engineer.

**MATERIALS**

The following sections of the standard specifications shall apply:

Sidewalks, Driveways, Bicycle Paths, and Vegetation Control Strips 608-2

The following ASTM Specifications shall apply:

Standard Specification for Pigments for Integrally Colored Concrete C979

Integral Color Concrete Admixture.

The color shall be as indicated in the contract documents. For each color used, the pigment shall be from the same batch or lot unless otherwise approved.

Color admixtures for integrally colored concrete shall be:

- certified by the manufacturer as meeting the requirements of ASTM C979. The Contractor shall provide the manufacturer’s certification verifying that the colored concrete admixture meets ASTM C979.
- added to the concrete mix per manufacturer’s recommendations at a dosage rate to achieve the color specified in the contract documents; the manufacturer’s recommended maximum dosage rate shall not be exceeded.
- packaged so that each dose is the proper dose for 1 cubic yard of concrete.

Imprinted Concrete

Use imprinting tools capable of imprinting the surface of the concrete with a uniform and aligned pattern and/or texture. Use a clear release agent as specified by the imprinting tool manufacturer. These materials shall be approved prior to their use. Formliners shall be composed of elastomeric urethane, polyvinyl chloride (PVC) or ABS material designed for their intended shape and number of reuses to achieve the desired pattern. Formliners shall not be worn, damaged, compromise the desired patterning effect, or cause damage to the concrete during form removal.

Color Matching Joint Material

When specified for any location, use a color matched caulking compound designed for joint sealing.

**608.010X0005 - COLORED AND IMPRINTED PORTLAND CEMENT CONCRETE  
SIDEWALK AND DRIVEWAYS**

**CONSTRUCTION DETAILS**

The following sections of the standard specifications shall apply:

Sidewalks, Driveways, Bicycle Paths, and Vegetation Control Strips 608-3

with the following modifications:

Test Panels

Per §105-02, The Contractor shall have sufficient skill and experience to properly perform colored and imprinted concrete work. The Contractor shall construct a job site test panel for each individual color and pattern or combination of color and pattern specified in the contract documents. The test panel(s) shall be 5 feet x 5 feet, minimum, constructed at a selected location. As many test panels will be constructed as are necessary to produce approved sample panels. The permanent work shall be consistent with the appearance of the approved test panel(s). The test panel(s) shall not be incorporated into the work and will be removed when ordered.

Color Concrete Admixture

Add the integral color admixture at the manufacturer’s recommended dosage rate. This rate is to remain constant for all batches of concrete produced. Prior to placing concrete, the Contractor shall protect adjacent surfaces and structures from spatters. Once a portion of the batch has been placed, no additional water shall be added to the remaining batch.

To integrally color the concrete, introduce the color additive into the mixer drum in a manner recommended by the manufacturer. The quantity of concrete being delivered shall be no less than one-third the capacity of the mixer drum. Batch the concrete in full cubic yard increments.

After the concrete is placed, apply a color matching hardener evenly to the plastic surface by the “dry shake” method as recommended by the manufacturer.

Architectural Patterned and Textured Concrete

The Contractor shall,

- screed concrete to the finished grade and apply the release agent evenly over the entire imprinting tool. Using methods recommended by the manufacturer, apply pre-approved imprinting tools to the surface while the concrete is still plastic. The requirement for a lightly broomed surface is waived.
- unless otherwise specified, score or saw cut the surface to a minimum depth of ¼ the thickness of the slab at intervals that are consistent with the architectural pattern or as indicated in the contract documents. If the saw cut option is used, the Contractor shall be responsible for performing the saw cut operation at such time as to minimize the possibility of spalling and/or cracking.

**608.010X0005 - COLORED AND IMPRINTED PORTLAND CEMENT CONCRETE  
SIDEWALK AND DRIVEWAYS**

- tool the edges, joints and scored areas in a manner consistent with the imprinting pattern.

Within 24 hours, remove release agent with pressure wash and apply a pre-approved sealer, recommended by the coloring manufacturer, at a rate consistent with manufacturer’s specifications.

Color Matching Joint Material

Install pre-molded resilient joint filler (§705-07) where the sidewalk line intersects a building, walk, permanent structure, or other location designated, to within 1-inch of the top of the slab. Caulk the top 1-inch of the joint with color matching caulking compound.

**METHOD OF MEASUREMENT**

The work will be measured as the number of cubic yards, to the nearest 0.1 cubic yard of colored, imprinted, or colored and imprinted Portland cement concrete sidewalk installed.

**BASIS OF PAYMENT**

The unit bid price per cubic yard of colored, imprinted, or colored and imprinted Portland cement concrete sidewalk furnished and installed shall include the cost of all labor, equipment and materials necessary to satisfactorily complete the work.

The cost of construction and removal of the test panel(s) is to be included in the price bid for the specified item(s).

*Payment will be made under:*

<b>ITEM NUMBER</b>	<b>ITEM DESCRIPTION</b>	<b>UNIT</b>
608.01020005	Colored and Imprinted Portland Cement Concrete Sidewalk	CY
608.01030005	Colored Portland Cement Concrete Sidewalk	CY
608.01040005	Imprinted Portland Cement Concrete Sidewalk	CY

**ITEM 608.21000003 - CAST IRON EMBEDDED DETECTABLE WARNING UNITS**

**DESCRIPTION**

Section §608-1 of the Standard Specifications shall apply.

**MATERIALS**

Section §608-2.07 of the Standard Specification shall apply with the following modifications:

Embedded Detectable Warning Units 726-02

All embedded detectable warning units shall be cast iron. No other material will be accepted. Installation of detectable warning units shall be in accordance with manufacturer's recommendations. All detectable warning units shall have a natural finish color.

**CONSTRUCTION DETAILS**

Cast iron detectable warning units shall be installed in wet concrete as directed by the manufacturer. Follow all applicable manufacturer's requirements for environmental conditions, surface preparation, installation procedures, curing procedures, and materials compatibility.

**METHOD OF MEASUREMENT**

Section §608-4.07 of the Standard Specifications shall apply.

**BASIS OF PAYMENT**

The unit bid price per square yard shall include all labor, material, and equipment necessary to satisfactorily complete the work, including bedding material. No adjustment shall be made for concrete removed to accommodate embedded units.

Payment will be made under:

<b>Item No.</b>	<b>Item</b>	<b>Pay Unit</b>
608.21000003	Cast Iron Embedded Detectable Warning Units	Square Yard

**ITEM 611.19010024 - POST-PLANTING CARE WITH REPLACEMENT - MAJOR DECIDUOUS TREES**

**ITEM 611.19020024 - POST-PLANTING CARE WITH REPLACEMENT - MINOR DECIDUOUS TREES**

**ITEM 611.19030024 - POST-PLANTING CARE WITH REPLACEMENT - CONIFEROUS TREES**

**ITEM 611.19040024 - POST-PLANTING CARE WITH REPLACEMENT - DECIDUOUS SHRUBS**

**ITEM 611.19050024 - POST-PLANTING CARE WITH REPLACEMENT - EVERGREEN SHRUBS**

**ITEM 611.19060024 - POST-PLANTING CARE WITH REPLACEMENT - VINES, GROUNDCOVERS**

**ITEM 611.19070024 - POST-PLANTING CARE WITH REPLACEMENT - HERBACEOUS PLANTS**

**DESCRIPTION**

This work consists of the care of newly planted and transplanted trees, shrubs, vines, groundcovers and other plants and replacement of plants in kind and as necessary, in accordance with the contract documents and as directed by the Engineer.

**MATERIALS**

Materials shall meet the requirements of the following subsections of Section 700 *Materials and Manufacturing*.

Water	712-01
Topsoil	713-01
Mulch for Landscape Bedding	713-05
Trees, Shrubs and Vines	713-06
Materials for the Protection of Plants	713-08
Pesticides	713-13

**CONSTRUCTION**

**Post-Planting Care.** The Contractor shall perform all work as specified under Standard Specification section **611-3.05 Post-Planting Care**.

**Replacement Planting.** Plants that die, become diseased or badly impaired during Post-Planting Care shall be removed and replaced in kind once with new, healthy plant material, in the same location as the initial planting. Replacement planting shall occur within the planting seasons shown in Standard Specification **Table 611-1**. For any plants replaced during the Post-Planting Care period, Post-Planting Care shall continue to the end of the period.

Replacement plants shall be planted, maintained and accepted per Standard Specification **Section 611-3.01**. Planting soil used in the initial planting shall be reused for replacement plants and shall be supplemented with topsoil at no additional cost if additional material is needed to meet grade and surface finish. Watering shall accompany backfilling, at no additional cost. No replacement tree shall be staked, guyed or anchored.



**ITEM 611.19010024 - POST-PLANTING CARE WITH REPLACEMENT - MAJOR DECIDUOUS TREES**

**ITEM 611.19020024 - POST-PLANTING CARE WITH REPLACEMENT - MINOR DECIDUOUS TREES**

**ITEM 611.19030024 - POST-PLANTING CARE WITH REPLACEMENT - CONIFEROUS TREES**

**ITEM 611.19040024 - POST-PLANTING CARE WITH REPLACEMENT - DECIDUOUS SHRUBS**

**ITEM 611.19050024 - POST-PLANTING CARE WITH REPLACEMENT - EVERGREEN SHRUBS**

**ITEM 611.19060024 - POST-PLANTING CARE WITH REPLACEMENT- VINES, GROUNDCOVERS**

**ITEM 611.19070024 - POST-PLANTING CARE WITH REPLACEMENT - HERBACEOUS PLANTS**

**METHOD OF MEASUREMENT.**

The quantity to be measured for payment will be the number of plants of each type cared for and, if necessary, replaced in kind.

**BASIS OF PAYMENT.**

The unit price bid shall include the cost of all labor, materials, and equipment necessary to satisfactorily complete the work.

Payment will be made under:

<b>Item No.</b>	<b>Item</b>	<b>Pay Unit</b>	
611.19010024	Post Planting Care with Replacement - Major Deciduous Trees		Each
611.19020024	Post Planting Care with Replacement - Minor Deciduous Trees		Each
611.19030024	Post Planting Care with Replacement - Coniferous Trees		Each
611.19040024	Post Planting Care with Replacement - Deciduous Shrubs		Each
611.19050024	Post Planting Care with Replacement - Evergreen Shrubs		Each
611.19060024	Post Planting Care with Replacement- Vines, Groundcovers		Each
611.19070024	Post Planting Care with Replacement - Herbaceous Plants		Each

**ITEM 615.08XX0005 – BENCH, TYPE XX**

**DESCRIPTION:**

The Contractor shall furnish and install benches as shown in the Contract Documents. The Contractor shall verify the type, quantity, location and installation method for each bench with the Engineer prior to ordering. This may include approval by owning or maintaining agencies other than NYSDOT.

**MATERIALS:**

As indicated in the contract documents.

**CONSTRUCTION DETAILS:**

The benches shall be installed in the locations indicated in the contract documents, in accordance with the manufacturer's instructions and as approved by the Engineer.

**METHOD OF MEASUREMENT:**

Quantity will be measured by the number of benches installed to the satisfaction of the Engineer.

**BASIS OF PAYMENT:**

The unit price bid for each bench shall include the cost of all labor, materials and equipment necessary to satisfactory complete the work.

**ITEM 615.92010011 – PRECAST CONCRETE STEPS (STRAIGHT)**

**ITEM 615.92020011 – PRECAST CONCRETE STEPS (RADIAL)**

**DESCRIPTION**

Under this work, the Contractor shall furnish and install precast concrete steps of the size and type, and at the locations as shown on the Contract Drawings.

**MATERIALS**

Materials shall meet the requirements specified in the following subsections of 700 – Materials except where modified herein.

Precast Concrete	704-03
Masonry Mortar	705-21

A. Reinforcing Bars: Reinforcing Bars shall comply with Section 709-01 *Bar Reinforcement* and be Epoxy-Coated Grade 60.

B. Grout Materials:

Nonmetallic, Nonshrink Grout: Premixed, nonmetallic, noncorrosive, nonstaining grout containing selected silica sands, portland cement, shrinkage-compensating agents, plasticizing and water-reducing agents, complying with ASTM C 1107, Grade A for drypack and Grades B and C for flowable grout and of consistency suitable for application within a 30-minute working time or approved equal.

Sand-Cement Mortar: Portland cement, ASTM C 150, Type I, and clean, natural sand, ASTM C 144. Mix at ratio of 1 part cement to 4 parts sand, by volume, with minimum water required for placement.

Latex-Portland Cement Pointing Grout: ANSI A118.6 and as follows:

1. Dry-grout mixture, factory prepared, of portland cement, graded aggregate, and dry, redispersible, ethylene-vinyl-acetate additive for mixing with water; uniformly colored.
2. Commercial portland cement grout, factory prepared, with liquid styrene-butadiene rubber or acrylic-resin latex additive; uniformly colored.
3. Or approved equal

Colors: Steps shall match color and finish of approved sample.

C. Design Standards: Comply with ACI 318 and design recommendations of PCI MNL 120, "PCI Design Handbook - Precast and Prestressed Concrete," applicable to types of precast concrete units indicated.

All precast walking surfaces (steps) to have a minimum slip resistance of 0.65. Design Standards:

**ITEM 615.92010011 – PRECAST CONCRETE STEPS (STRAIGHT)**

**ITEM 615.92020011 – PRECAST CONCRETE STEPS (RADIAL)**

Comply with ACI 318 and design recommendations of PCI MNL 120, "PCI Design Handbook - Precast and Prestressed Concrete," applicable to types of precast concrete units indicated.

All precast walking surfaces (steps) to have a minimum slip resistance of 0.65.

**CONSTRUCTION DETAILS**

- A. Precast concrete steps shall be laid on the alignment and grade as shown on the plans to provide a uniform surface. No installation shall be done at temperatures below 32°F. Precast concrete steps shall not be placed on frozen subgrade as determined by the Engineer. The temperature of the subbase shall be 36°F or higher. There shall be no snow, frost, or standing water on the subbase.

The Contractor shall use installation equipment which is not bent, twisted, warped or damaged in any way. All wire ropes for cranes or lifting bars shall be of full sections and shall not be bent, kinked, twisted, torn or stretched. The lifting capacity of each lifting device shall be clearly marked.

- B. Reinforcement: Reinforce precast concrete units to resist handling, transportation, and erection stresses. Comply with recommendations in PCI MNL 117 for fabricating, placing, and supporting reinforcement. Clean reinforcement of loose rust and mill scale, earth, and other materials that reduce or destroy the bond with concrete. When damage to epoxy-coated reinforcing exceeds limits specified in ASTM A 775/A 775M, repair with patching material compatible with coating material and epoxy coat bar ends after cutting. Accurately position, support, and secure reinforcement against displacement during concrete-placement and consolidation operations. Completely conceal support devices to prevent exposure on finished surfaces. Place reinforcement to maintain at least 2-inch minimum coverage. Arrange, space, and securely tie bars and bar supports to hold reinforcement in position while placing concrete. Direct wire tie ends away from finished, exposed concrete surfaces. Arrange, space, and securely tie bars and bar supports to hold reinforcement in position while placing concrete. Install welded wire fabric in lengths as long as practicable. Lap adjoining pieces at least one full mesh spacing and wire tie laps, where required by design. Offset laps of adjoining widths to prevent continuous laps in either direction.
- C. Grouting Connections: Grout connections where required or indicated. Retain grout in place until hard enough to support itself. Pack spaces with stiff grout material, tamping until voids are completely filled. Place grout to finish smooth, level, and plumb with adjacent concrete surfaces. Keep grouted joints damp for not less than 24 hours after initial set. Promptly remove grout material from exposed surfaces before it affects finishes or hardens.

**ITEM 615.92010011 – PRECAST CONCRETE STEPS (STRAIGHT)**  
**ITEM 615.92020011 – PRECAST CONCRETE STEPS (RADIAL)**

**METHOD OF MEASUREMENT**

Precast concrete steps will be measured as the number of cubic yards of precast concrete steps incorporated in the completed work.

**BASIS OF PAYMENT**

The unit price bid per cubic yard of Precast Concrete steps shall cover the cost of furnishing all labor, material, equipment, insurance, and incidentals required to furnish, deliver, and install precast concrete steps.

Payment will be made as follows:

<b>Item:</b>	<b>Description:</b>	<b>Pay Unit:</b>
615.92010011	Precast Concrete Steps (Straight)	C.Y.
615.92020011	Precast Concrete Steps (Radial)	C.Y.

## **ITEM 627.50140008 - CUTTING PAVEMENT**

### **DESCRIPTION:**

The contractor shall cut existing asphalt pavement, concrete pavement, asphalt surface course, or asphalt concrete overlay on concrete pavement at the locations indicated and detailed on the plans and as directed by the Engineer.

### **MATERIALS:**

None specified.

### **CONSTRUCTION DETAILS:**

Existing pavement and overlay shall be cut perpendicular to the roadway surface along neat lines, and to the depth indicated on the plans and typical sections, using appropriate equipment. After the pavement has been cut through, the Contractor may use pry bars, pneumatic tools or other methods, to pry loose the pavement to be removed from the pavement that is to remain. A pavement breaker may be used to break up the pavement to be removed after the pavement has been completely cut through and completely free from the pavement to remain.

When pavement cutting is called for in the Contract documents, if a neat vertical face with minimal shatter is obtained by performing an adjacent operation (such as milling) which eliminates the need to perform a separate pavement cutting operation, payment will be made for both the pavement cutting item and the item for the adjacent operation.

Any existing pavements and curbs not indicated to be removed that are damaged by the contractor's operations, shall be repaired at no additional cost to the State. Pavement cutting that the contractor chooses to do for his/her own convenience shall not receive any additional payment from the State.

### **METHOD OF MEASUREMENT:**

The quantity to be measured will be the number of linear feet of pavement cutting satisfactorily completed.

### **BASIS OF PAYMENT:**

The unit price bid per linear foot of pavement cutting shall include the cost of all labor, materials, and equipment necessary to satisfactorily complete the work.

Payment for prying, breaking, removal and disposal of cut pavement shall be made through other appropriate items.

**ITEM 640.25000010 - BLUE REFLECTORIZED PAVEMENT MARKING PAINT  
FOR HANDICAPPED PARKING SPACES**

All of the provisions of Section 640 pertaining to White Paint ReflectORIZED Pavement Stripes shall apply except for the following:

The pavement marking paint shall be tinted blue prior to application. The color of the paint shall be such that a prepared color chip shall be a reasonable visual match to Federal Color Standard No. 595B, Color 15180. Viewing shall be done under normal daylight.

Application of the blue reflectORIZED pavement marking paint will be restricted to parking and passenger loading zones and other marking which are specifically intended for accessibility by handicapped persons, as detailed in the plans.

## **ITEM 645.7300001 - ORNAMENTAL SIGN**

### **DESCRIPTION**

Under this item, the Contractor shall furnish and install an ornamental sign, as shown in the Contract Documents or as directed by the Engineer.

### **MATERIALS**

As indicated in the contract documents.

### **CONSTRUCTION DETAILS**

The Contractor shall submit shop drawings showing the dimensioned layout of lettering and artwork, color keys and other details as indicated in the Contract Documents to the Regional Landscape Architect for approval prior to beginning work.

Signs shall be installed as depicted and at the locations shown in the Contract Documents.

### **METHOD OF MEASUREMENT**

The quantity of signs to be paid for under this item will be the number of signs furnished and installed as indicated in the Contract Documents or as directed by the Engineer.

### **BASIS OF PAYMENT**

The unit price bid per sign furnished and installed will include the cost of all labor, materials, hardware, paint, and equipment necessary to satisfactorily complete the work.



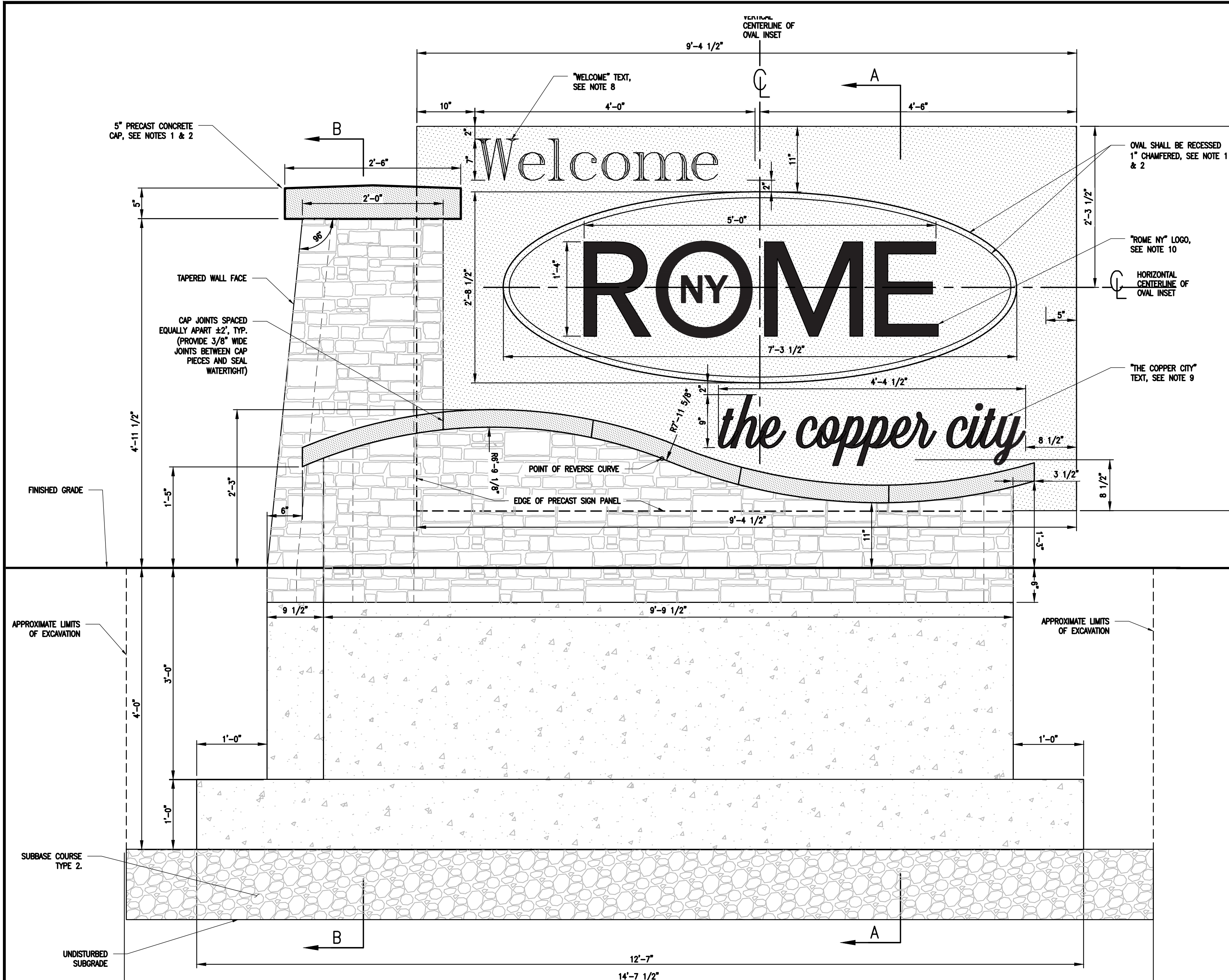

GATEWAY MONUMENT SIGN | FRONT

SCALE: 1" = 1'-0"

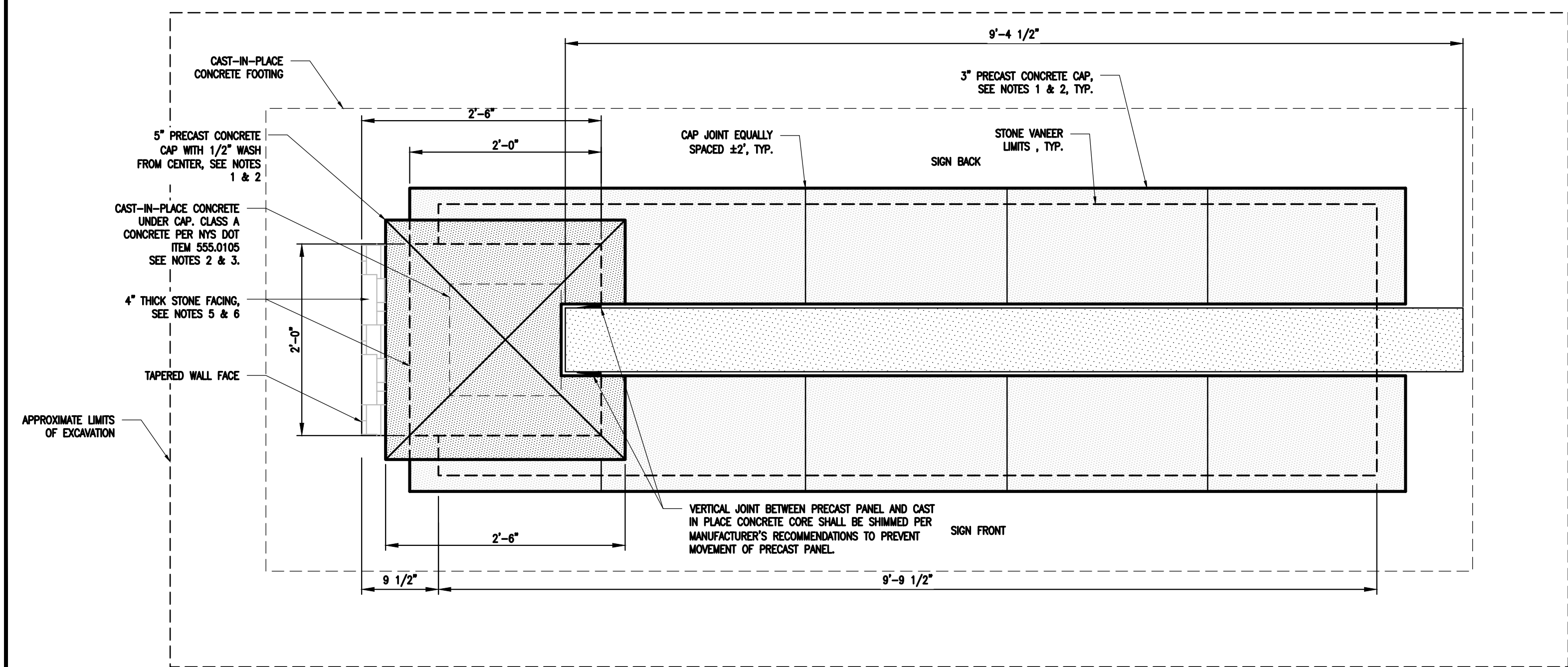

PLAN VIEW

SCALE: 1" = 1'-0"

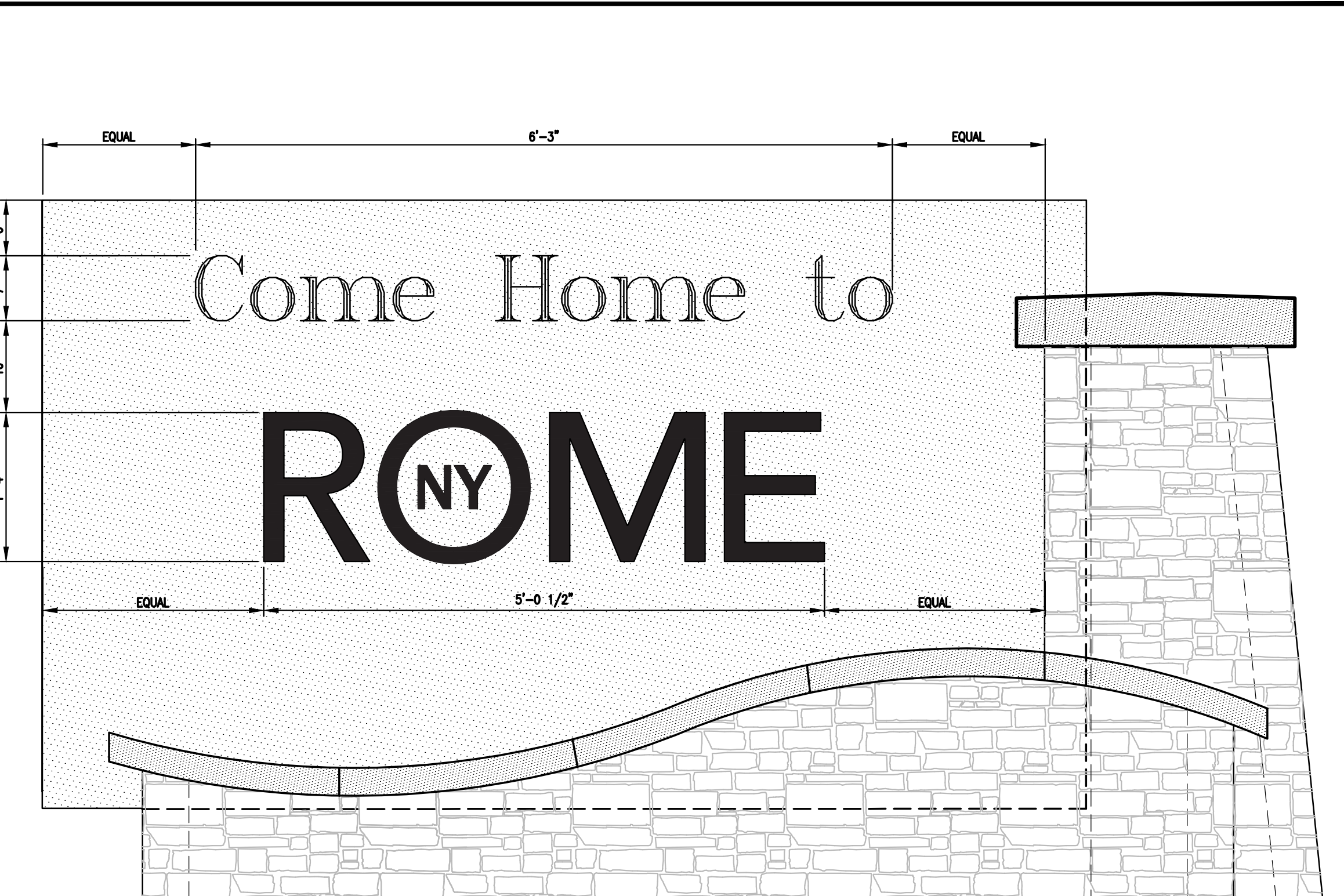

GATEWAY MONUMENT SIGN | BACK

GATEWAY MONUMENT SIGN NOTES:

- PRECAST CONCRETE SIGN PANEL COLOR SHALL BE WHITE. FINISH SHALL BE LIGHT ETCH. PRECAST CONCRETE CAP COLOR SHALL BE WHEAT. FINISH SHALL BE LIGHT ETCH, AS MANUFACTURED BY SOUTHSIDE PRECAST (WWW.SOUTHSIDEPRECAST.COM) OR APPROVED EQUAL. CONTRACTOR SHALL SUBMIT SAMPLES OF PRECAST CONCRETE IN THE SPECIFIED COLOR AND FINISH FOR APPROVAL PRIOR TO CONSTRUCTION.  
INTERIOR SURFACE OF OVAL ON THE PRECAST CONCRETE SIGN PANEL SHALL BE STAINED TO MATCH COLOR OF THE PRECAST CONCRETE CAPS. CONTRACTOR SHALL SUBMIT COLOR SAMPLE OF STAIN ON THE SPECIFIED PRECAST CONCRETE COLOR AND FINISH FOR APPROVAL PRIOR TO FABRICATION.
- CONTRACTOR SHALL SUBMIT SHOP DRAWINGS DETAILING CONNECTIONS BETWEEN PRECAST CONCRETE ELEMENTS AND CAST-IN-PLACE CONCRETE FOOTINGS AND BETWEEN ONE ANOTHER. CONNECTIONS SHALL BE HIDDEN FROM VIEW IN THE FINISHED PRODUCT. DESIGN SHALL COMPLY WITH ACI 318 AND DESIGN RECOMMENDATIONS OF PCI MNL-120, "PCI DESIGN HANDBOOK".  
ALL RECESSED LIFTING DEVICES SHALL BE LIMITED TO THE TOP AND BOTTOM OF PRECAST CONCRETE ELEMENTS AND ARE NOT ALLOWED ON THE EXPOSED FACES ON FRONT, BACK OR SIDES OF THE ELEMENTS.
- EXPOSED JOINTS BETWEEN PRECAST CONCRETE ELEMENTS SHALL BE SEALED WITH SIKAFLEX-15 LM HIGH PERFORMANCE, LOW-MODULUS ELASTOMERIC SEALANT BY SIKA (USAKIKO.COM) OR APPROVED EQUAL. CONTRACTOR SHALL PROVIDE COLOR SAMPLES OF SEALANT TO BE MATCHED WITH PRECAST CONCRETE ELEMENTS PRIOR TO INSTALLATION.
- ALL EXPOSED PRECAST CONCRETE SURFACES SHALL BE TREATED WITH AN ANTI-GRAFFITI PROTECTIVE COATING. ANTI-GRAFFITI SHALL BE SURE KLEAN WEATHER SEAL BLOK-GUARD & GRAFFITI CONTROL II OR APPROVED EQUAL. CONTRACTOR SHALL PROVIDE A SAMPLE OF THE ANTI-GRAFFITI ON THE SPECIFIED PRECAST CONCRETE MATERIAL, COLOR AND FINISH. SAMPLE SHALL NOT BE PART OF THE FINISHED GATEWAY SIGN.
- 4" THICK STONE VENEER SHALL BE BARNWOOD BLUE BY BUECHEL STONE CORP WWW.BUECHELSTONE.COM OR APPROVED EQUAL. PATTERN SHALL BE ASHLAR. FINISH SHALL BE SPLIT. MORTAR SHALL BE GRAY.  
CONTRACTOR SHALL PROVIDE A 5'X5' MOCKUP OF STONE VENEER WITH SPECIFIED STONE, FINISH, PATTERN AND MORTAR COLOR FOR APPROVAL PRIOR TO CONSTRUCTION. SAMPLE SHALL NOT BE PART OF THE FINISHED GATEWAY SIGN.
- CONTRACTOR SHALL SUBMIT SHOP DRAWINGS DETAILING THE CONNECTION OF THE STONE VENEER TO CAST-IN-PLACE CONCRETE CORE PRIOR TO CONSTRUCTION.
- PLASTIC TUBING WEEP SHALL BE ONE PIECE FLEXIBLE EXTRUSION MADE FROM UV RESISTANT POLYPROPYLENE COPOLYMER LENGTH TO EXTEND FROM EXTERIOR FACE OF STONE TO CAVITY BEHIND. COLOR SELECTED FROM MANUFACTURERS STANDARDS TO CLOSELY MATCH STONE.
- "WELCOME" AND "COME HOME TO" TEXT SHALL BE LASER CUT ACRYLIC SIGN LETTERS BY GEMINILETTERSDIRECT.COM OR APPROVED EQUAL. LETTERS SHALL BE MOUNTED FLUSH WITH PRECAST PANEL.  
- FONT SHALL BE ROMANT  
- COLOR SHALL BE ORANGE (RGB 204, 115, 60 CMYK 16, 63, 87, 3)  
- LETTER THICKNESS SHALL BE 3/8"  
- LETTERS SHALL HAVE 1-1/2" METAL THREADED PORTS ON THE REAR OF THE LETTER AS PER MANUFACTURERS RECOMMENDATIONS.
- "THE COPPER CITY" LOGO SHALL BE LASER CUT ACRYLIC SIGN LETTERS BY GEMINILETTERSDIRECT.COM OR APPROVED EQUAL. LETTERS SHALL BE MOUNTED FLUSH WITH PRECAST PANEL.  
- "THE COPPER CITY" LOGO SHALL BE PROVIDED TO THE CONTRACTOR IN ELECTRONIC FORMAT BY THE CITY OF ROME PRIOR TO FABRICATION  
- COLOR SHALL BE ORANGE (RGB 204, 115, 60 CMYK 16, 63, 87, 3)  
- LETTER THICKNESS SHALL BE 3/8"  
- LETTERS SHALL HAVE 1-1/2" METAL THREADED PORTS ON THE REAR OF THE LETTER AS PER MANUFACTURERS RECOMMENDATIONS.
- "ROME NY" LOGO SHALL BE LASER CUT ACRYLIC SIGN LETTERS BY GEMINILETTERSDIRECT.COM OR APPROVED EQUAL. LETTERS SHALL BE MOUNTED FLUSH WITH PRECAST PANEL.  
- "ROME NY" LOGO SHALL BE PROVIDED TO THE CONTRACTOR IN ELECTRONIC FORMAT BY THE CITY OF ROME PRIOR TO FABRICATION  
- COLOR SHALL BE BLACK  
- LETTER THICKNESS SHALL BE 3/8"  
- LETTERS SHALL HAVE 1-1/2" METAL THREADED PORTS ON THE REAR OF THE LETTER AS PER MANUFACTURERS RECOMMENDATIONS.
- LOCATION OF GATEWAY MONUMENT SIGN TO BE VERIFIED BY CITY OF ROME PRIOR TO FABRICATION AND INSTALLATION.



280 East Broad Street  
Suite 200  
Rochester, NY 14604  
www.bergmannpc.com

CITY OF ROME

198 North Washington Street  
Rome, New York 13440

WELCOME TO ROME  
GATEWAY SIGN

State Route 26  
Rome, New York

Date Revised	Description

Professional Certification: I certify that these documents were prepared or approved by me, and that I am a duly licensed Landscape Architect under the laws of the state, commonwealth or district of New York. License No. 001725  
Expiration Date: 4/30/2024



9-12-23

BID SET

Copyright © Bergmann Associates, Architects, Engineers, Landscape Architects & Surveyors, D.P.C.

Project Manager L. PODOWSKI KING	Discipline Lead L. PODOWSKI KING
Designer T. LIDDELL / H. ONEILL	Reviewer E. SHAW
Date Issued SEPTEMBER 12, 2023	Project Number 016258.00

Sheet Name

GATEWAY SIGN DETAILS

Drawing Number

C500



**ITEM 645.81090003 – RETROREFLECTIVE SIGN POST STRIP**

**DESCRIPTION**

This work shall consist of furnishing and installing Retroreflective Sign Post Strips in accordance with the contract documents.

**MATERIALS**

The retroreflective surface of Retroreflective Sign Post Strip shall conform to §730-05 Retro-Reflective Sign Sheeting - NYSDOT Class A sign sheeting and appear on the Department’s Approved List of Materials and Equipment for Reflective Sign Sheeting.

Note: Signs supplied before March 1, 2023, may be fabricated with NYSDOT approved ASTM D4956 Type III/IV and IX retro-reflective sign sheeting. The grade of sheeting shall match the grade of sheeting on the sign panel that the strip supplements.

Nylon or plastic washers shall be installed between fastener bolt heads (or nuts) and the reflective sheeting on the face of the strip.

The color of the retroreflective sheeting on the Retroreflective Sign Post Strip shall match the background color of the sign, except that the color of the strip for the YIELD and DO NOT ENTER signs shall be red.

Retroreflective Sign Post Strips shall be made of durable, UV-stabilized plastics or aluminum panels in accordance with §730-01.

Hardware to mount Retroreflective Sign Post Strips to sign posts shall conform to §715-16 Stainless Steel Connecting Products, or §730-22 Stiffeners, Overhead Brackets, and Miscellaneous Hardware. Hardware to connect Retroreflective Sign Post Strips to sign posts shall be tamper resistant.

**CONSTRUCTION DETAILS**

Retroreflective Sign Post Strips shall be at least 2 inches in width and shall be in accordance with the contract documents. Retroreflective Sign Post Strips shall be placed for the full length of the support from the sign to 2 feet above the edge of the roadway.

Retroreflective Sign Post Strips shall be attached to the sign posts by mechanical means with standard nuts and bolts, clamps, brackets, or strapping according to the manufacturer’s instructions. Retroreflective Sign Post Strips shall not be attached to sign posts with adhesives.

**METHOD OF MEASUREMENT**

This work will be measured as the number of Retroreflective Sign Post Strips satisfactorily furnished and installed.

**BASIS OF PAYMENT**

The unit price bid shall include the cost of furnishing all labor, materials, and equipment necessary to satisfactorily complete the work.

**ITEM 647.83001002 - REMOVAL AND DISPOSAL OF DELINEATORS AND/OR  
REFERENCE MARKERS WITH OR WITHOUT POSTS**

**DESCRIPTION:**

This work shall include the removal and disposal of existing delineators and/or reference markers, including posts and associated hardware, as designated in the Contract Documents.

All provisions of Section 647 shall apply to this specification except as modified below.

**MATERIALS:**

Not specified.

**CONSTRUCTION DETAILS:**

Existing delineators and/or reference markers and supports (when an independent system, and not part of a sign support system) shall be removed from the site and become the property of the contractor. Post foundations shall be completely removed (when applicable).

**METHOD OF MEASUREMENT:**

The work will be measured as the number of delineators and/or reference markers removed and disposed. When multiple delineators/markers are attached to the same support or support system or delineators/markers are mounted back to back, the work shall be paid as 1 each.

**BASIS OF PAYMENT:**

The unit price bid shall include the cost of furnishing all labor, materials, and equipment necessary to satisfactorily complete the work.

**ITEM 655.05010010 - RESETTING EXISTING SANITARY SEWER MANHOLE CASTINGS**

**DESCRIPTION:**

This work shall consist of resetting the frame (bottom ring) on the existing sanitary sewer manholes after replacing the brick masonry collar. This method shall be used for adjusting existing sanitary sewer manholes as indicated on the "Table of Sanitary Sewer Structures", unless otherwise directed and/or approved by the Engineer.

**MATERIALS:**

Materials shall meet the requirements of the following subsections of Section 700, "Materials Details".

Precast Concrete Paver	704-13
Mortar for Concrete Masonry	705-21

**CONSTRUCTION DETAILS:**

The existing frames, covers and appurtenances shall be removed, stored if necessary, cleaned and reset to the proposed grade indicated in the plans or as directed by the Engineer.

The Contractor shall remove the existing brick masonry collar in its entirety and construct a new brick masonry collar of the height required.

The Contractor shall thoroughly clean the surface of the top slab of the manhole around the opening to insure proper bond to the satisfaction of the Engineer for the construction of the new brick masonry collar.

Upon completion, each structure shall be cleaned of any accumulation of silt, debris or foreign matter of any kind and shall be kept clean of such accumulation until final acceptance of the work.

**METHOD OF MEASUREMENT:**

This work will be measured by the number of existing frames, complete with covers and appurtenances, reset to grade on existing sanitary sewer manholes as specified herein.

**BASIS OF PAYMENT:**

The unit price bid for resetting each frame shall include the cost of all labor, materials and equipment necessary to complete the work.

Any frames, covers and appurtenances damaged or misplaced shall be replaced at the Contractor's expense.

**ITEM 655.07010010 - CAST FRAME F1, WITHOUT CURB BOX AND WITH  
RETICULINE GRATE G1**

**ITEM 655.07020010 - CAST FRAME F2, WITHOUT CURB BOX AND WITH  
RETICULINE GRATE G2**

**ITEM 655.07030010 - CAST FRAME F3, WITHOUT CURB BOX AND WITH  
RETICULINE GRATE G3**

All conditions and requirements of Items 655.0701, 655.0702, and 655.0703 of the Standard Specifications shall apply except for the following modifications:

These shall be cast frame without curb box and with reticuline grate as detailed on the plans.

**ITEM 660.6500NN01 - ALTERING UTILITY MANHOLES AND VAULTS**

**DESCRIPTION:**

The work shall consist of the alteration of existing utility manholes and vaults in accordance with the contract plans.

**MATERIALS:**

Materials used for the alteration of utility manholes and vaults shall meet the requirements of §604-2.01 and shall be as indicated on the contract plans. Structures originally constructed with concrete block, common brick, or concrete brick shall be altered with Precast Concrete Pavers, §704-13, unless indicated otherwise on the contract plans.

**CONSTRUCTION DETAILS:**

Excavation shall be in conformance with the construction details of Subsection 206-3, Trench Culvert and Structure Excavation.

Reconstruction and adjustment of existing utility manholes and vaults shall be as detailed and specified on the contract plans. Construction with cast-in-place concrete shall conform to the requirements of Section 555, Structural Concrete.

Frames and covers to be reused shall be removed, cleaned, and reset at the required elevations. New frames and manhole covers shall be installed when specified.

No structure shall be backfilled until all the mortar has completely set. The requirements of Subsection 203-3.15, Fill and Backfill at Structures, Culverts, Pipes Conduits, Direct Burial Cable, shall apply.

**METHOD OF MEASUREMENT:**

Altering utility manholes and vaults will be measured by the number of structures altered.

**BASIS OF PAYMENT:**

The unit price bid for each shall include the cost of all materials, labor, and equipment necessary to satisfactorily complete the work, including all necessary cleaning, excavation, backfill, and replacement of any pavement, shoulder, and sidewalk courses, subcourses, curbs, drives, lawns, and any other surface. Frames and covers to be reused that are broken by the Contractor's operations shall be replaced in-kind at the Contractor's expense. New frames and covers will be paid for under the appropriate payment items for Frames and Grates in Section 655.

Payment will be made under:

<b><u>ITEM NO.</u></b>	<b><u>ITEM DESCRIPTION</u></b>	<b><u>PAY UNIT</u></b>
660.6500NN01	Altering Utility Manholes and Vaults	Each

NN = Serialized 01 to 99

## **ITEM 670.03020011 - RELOCATE LAMPOST ASSEMBLY**

### **DESCRIPTION:**

Under this item the contractor shall remove, store and install at a new location the lamppost assemblies designated on the plans or ordered relocated by the Engineer.

### **MATERIALS:**

Anchor Bolts - Anchor Bolts shall be manufactured from ASTM A449 or A576 steel, grades 1020 through 1050, inclusive, having a minimum yield strength of 50K psi. A hex nut, lock washer, and flat washer shall be supplied with each anchor bolt. The hex nut and flat washer shall be manufactured in accordance with ASTM A325 and the lock washer shall be manufactured in accordance with ANSI B18.21.1. The nuts, washers, and the top 12 in. of the anchor bolts shall be galvanized in accordance with the requirements for Type II galvanizing as stated in Section 719-01, Galvanized Coatings and Repair Methods. The anchor bolts shall be arranged on a bolt circle diameter matching the existing transformer base.

### **CONSTRUCTION DETAILS:**

Subsection 670-3.01, 3.06, 3.14, 3.15, 3.16, and 3.17 shall apply. The contractor shall carefully remove the existing lamppost assembly, including any arms, luminaires, bases, etc. from its existing location and store if necessary. The complete lamppost assembly shall be installed and made operational at the new location in accordance with the plans, specifications and as ordered by the Engineer. All connections in the new pullboxes and relocated transformer bases shall be similar to those in the existing transformer bases and shall be subject to the approval of the Engineer. Where possible, existing connectors, shall be used as approved by the Engineer. Any components of the lamppost assembly damaged during removal, storage or installation shall be replaced or repaired to the satisfaction of the Engineer at the contractor's expense. The contractor shall be responsible for notifying the Utility Company prior to beginning any operations so that the affected circuit may be disconnected. In order to minimize darkened roadway/stairway areas the contractor will not be permitted to have more than one circuit disconnected at any one time.

### **METHOD OF MEASUREMENTS:**

The work shall be measured by the number of complete lamppost assemblies relocated in accordance with the plans, specifications and directions of the Engineer.

### **BASIS OF PAYMENT:**

The unit price bid shall cover the cost of removing, storing and reinstalling the lamppost assembly including all connections in the transformer base and pullbox, conductor, electrical components, splices, fuses and connectors, anchor bolts, hardware, incidentals, labor, equipment and all other materials necessary to complete the work.



**ITEM 670.14480010 - RESETTING ELECTRIC PULLBOX COVERS AND FRAMES**

**DESCRIPTION.**

Under this item the Contractor will be required to raise or lower existing electric pullbox covers and frames complete to the grade as furnished by the Engineer.

**MATERIALS.**

Concrete shall be Class A meeting the requirements of Section 501. Other materials shall meet the requirements specified in the following subsections of Section 700 of the Standard Specifications:

Common Brick	704-01
Masonry Mortar	705-21

**CONSTRUCTION DETAILS.**

All adjustments shall be made with Class A Concrete and/or common brick.

Where ordered, the covers and frames shall be set in a mortar bed on the existing structures.

If any part of the pullbox, cover or frame is broken through carelessness on the part of the Contractor, it shall be replaced by the Contractor.

**METHOD OF MEASUREMENT.**

This work will be measured as the number of pullbox covers and frames reset.

**BASIS OF PAYMENT.**

The unit price bid for each pullbox cover and frame reset shall include the cost of all labor, materials, including cement, equipment and incidentals necessary to complete the work. No extra payment will be made for the replacement of the pullbox, cover or frame broken through carelessness on the part of the Contractor.

12/23/08E

3/15/96 M  
Rev 01/04/2001

**ITEM 670.15NN0005 – FURNISH AND INSTALL DECORATIVE LIGHT POLE ASSEMBLY**

The requirements of NYSDOT Standard Specification Section 670 – Highway Lighting System shall apply except as modified below:

**DESCRIPTION**

This work shall consist of furnishing and installing Decorative Light Pole Assembly as indicated and in accordance with the Contract Documents and as directed by the Engineer, including all material necessary to make the light operational.

**MATERIALS**

A Decorative Light Pole and Luminaire consists of the entire above ground assembly, including the pole, pole arm, photocell and/or luminaire as specified in the contract documents.

**CONSTRUCTION DETAILS**

The Decorative Light Pole Assembly shall be installed at locations shown in the contract documents. The manufacturer's installation instructions shall be strictly followed. All Roadway Light Poles and Luminaires shall be installed in accordance with the National Electrical Code (NEC) in force at time of construction, the Local Utility Companies Regulations and any Local Ordinances. The Contractor shall be responsible for all electrical inspections, inspections fees, permits, and permit fees.

The Contractor is responsible for any damage to the light poles and/or luminaires which resulted from their delivery / operations. Any component so damaged shall be replaced or repaired, as directed by the Engineer, at no cost to the Contract.

**METHOD OF MEASUREMENT**

The quantity will be measured as the number of Decorative Light Poles and Luminaires satisfactorily furnished and installed in accordance with the Contract Documents or as directed by the Engineer.

**BASIS OF PAYMENT**

The unit price bid shall include the cost of furnishing all labor, materials and equipment necessary to complete the work including poles, arms, brackets, luminaires, photocells, in pole wiring, fuse assemblies and terminations, base covers, and all necessary hardware/fittings for a complete operation of unit.

**ITEM 670.15NN0005 – FURNISH AND INSTALL DECORATIVE LIGHT POLE ASSEMBLY**

The cost of the foundation will be paid for under its respective item.

<b><u>ITEM NO.</u></b>	<b><u>ITEM DESCRIPTION</u></b>	<b><u>UNIT</u></b>
670.15NN0005	Furnish and Install Decorative Light Pole Assembly	Each

Note: NN – Serialization by type as shown on plans.

## **ITEM 670.5307NN04 - POWER POINT DISCONNECT ASSEMBLY**

### **DESCRIPTION:**

This work shall consist of the Contractor furnishing and installing new power point disconnect equipment in accordance with contract documents, specifications or at the direction of the Engineer.

### **MATERIALS:**

The specific components used in the construction of new power point disconnect equipment shall be as shown on the contract documents and meet the requirements of Section 670-2.

If a meter is required, it shall be furnished by the utility company and installed by the Contractor.

The Contractor shall submit shop drawings or catalog cuts of all proposed equipment to the Engineer for approval in accordance with Section 670-3.02.

### **CONSTRUCTION DETAILS:**

The requirements of Section 670-3 shall apply.

### **METHOD OF MEASUREMENT:**

The work will be measured as the number of complete units installed and operational.

### **BASIS OF PAYMENT:**

The unit price bid for each unit shall include the cost of labor, materials and equipment necessary to satisfactorily complete the work, including conduit elbows, anchor bolts, grounding system, all appurtenances, excavation, special fill, and any protective system(s) required to ensure the safety of the workers and the public.

NN = Serialized Location

**ITEM 680.51010009 - Alter Elevation of Pullbox, Type 1 (Raising above 5 inches)**

**ITEM 680.51020009 - Alter Elevation of Pullbox, Type 2 (Raising below 5 inches or resetting)**

**ITEM 680.51030009 - Alter Elevation of Pullbox, Type 3 (Lowering)**

## **DESCRIPTION**

This work shall consist of altering the elevation of an existing pullbox frame and cover in accordance with the details in the plans, specifications, or directions of the Engineer.

## **MATERIALS**

The materials used to alter the existing pullbox shall conform to the requirements of Subsection 680-2 MATERIALS, Section 701-02 MASONRY AND MORTAR CEMENT, and Section 704-01 COMMON BRICK. Materials not specified shall be approved by the Engineer

## **CONSTRUCTION DETAILS**

The applicable provisions of Subsection 680-3 CONSTRUCTION DETAILS, shall apply in addition to the following:

Existing pullbox covers are intended to be reused. If damaged or lost by the contractor, they will be replaced by the contractor. If the pullbox cover is found to be missing or unsatisfactory, through no fault of the Contractor, the state will supply the cover that shall be properly replaced by the Contractor.

## **METHOD OF MEASUREMENT**

The measure for payment is the number of pullbox covers that are altered in accordance with the contract documents.

## **BASIS OF PAYMENT**

The requirements of Subsection 680-5.01 General, shall apply with the following additional provisions:

The unit price bid for each altered pullbox shall include all costs for excavation, backfill, removal of concrete, furnishing concrete, placing concrete, bonding compounds, reinforcing bars, bricks and drilling and grouting to reset frames.

- ITEM 680.51010009 ALTER ELEVATION OF PULLBOX, TYPE 1 (RAISING ABOVE 5 INCHES)
- ITEM 680.51020009 ALTER ELEVATION OF PULLBOX, TYPE 2 (RAISING BELOW 5 INCHES OR RESETTING)
- ITEM 680.51030009 ALTER ELEVATION OF PULLBOX, TYPE 3 (LOWERING)

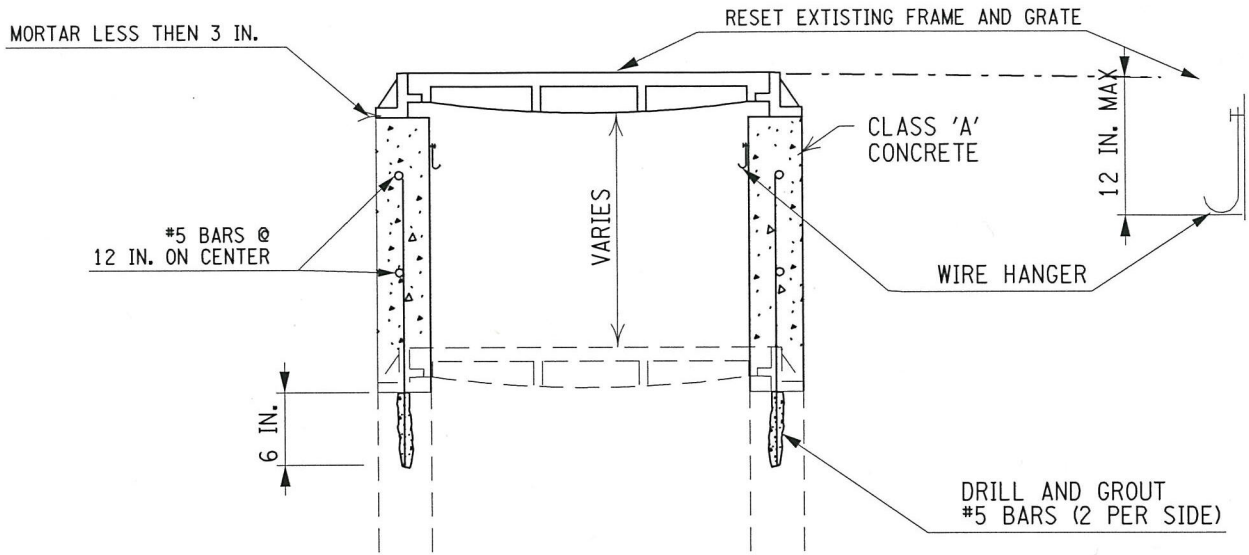

DETAIL ITEM 680.51010009 ALTER ELEVATION OF PULL BOX  
 TYPE I - RAISING (ABOVE 5 INCHES)  
 N.T.S.

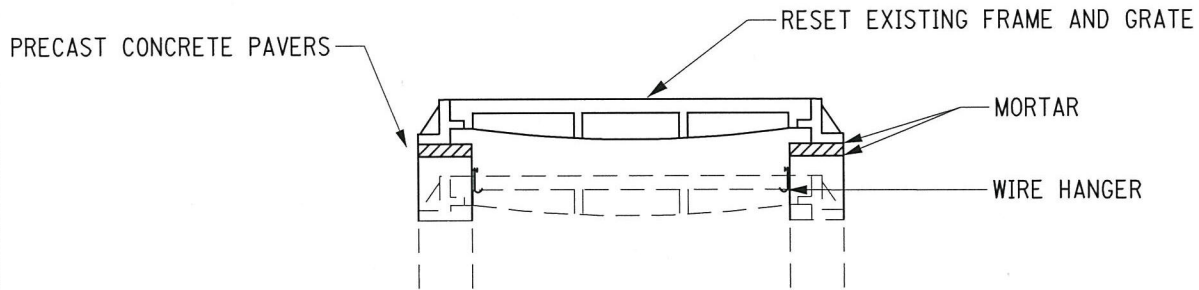

DETAIL ITEM 680.51020009 ALTER ELEVATION OF PULL BOX  
 TYPE II - RESETTING OR RAISING (BELOW 5 INCHES)  
 N.T.S.

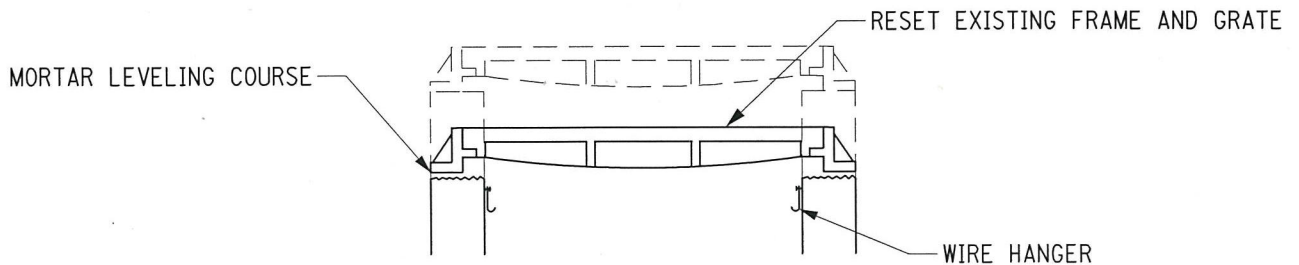

DETAIL ITEM 680.51030009 ALTER ELEVATION OF PULL BOX  
 TYPE III - LOWERING  
 N.T.S.

**ITEM 680.77XXX05 - MODIFY TRAFFIC SIGNAL INSTALLATION**  
**ITEM 680.79XXX05 - REMOVE TRAFFIC SIGNAL INSTALLATION**  
**ITEM 680.50XXX05 - ALTER ELEVATION OF POLE FOUNDATION**  
**ITEM 680.50500005 - REMOVE POLE FOUNDATION**  
**ITEM 680.51XXX05 - ALTER ELEVATION OF PULL BOXES**  
**ITEM 680.90000005 - RESET POLE**

**DESCRIPTION:**

This work shall consist of modifying, removing, storing and/or disposing, reinstalling, refurbishing or replacing of elements of a traffic signal system in accordance with the contract documents and/or directions of the Engineer.

Where not specifically covered in the contract documents the work shall be in accordance with the latest national, local and industrial standards or codes which are usually applied to such work and the requirements of the maintaining agency.

**MATERIALS:**

When an existing system is to be altered, modified or relocated, the existing material shall be reused in the revised system, removed, salvaged or disposed of as shown in the contract documents, as specified in the special provisions or as directed by the Engineer. When new materials must be provided under the modification work they shall conform to the requirements of Standard Specifications Section 680-2, Materials whenever applicable. Materials not specified in Section 680-2 shall match the existing system as nearly as possible and meet the requirements of the owning agency.

**CONSTRUCTION DETAILS:**

The applicable provisions of Standard Specifications Section 680-3, Construction Details shall be complied with, in addition to the following:

Removing and Salvaging

Care shall be exercised in removing signal and electrical equipment and any appurtenances attached to them so that elements to remain or be salvaged will not be damaged.

The Contractor will be required to replace or repair, to the satisfaction of the Engineer, any equipment damaged, destroyed or lost by the Contractor's operations or negligence as determined by the Engineer.

Existing equipment or material intended to be reused and found to be missing or unsatisfactory, through no fault of the Contractor, shall be properly replaced by the Contractor, using equipment or material supplied by the owning agency or under other items.

All equipment or materials specified for removal but not intended to be incorporated in the work shall be removed and disposed of as specified in the contract documents.

The owners of appurtenances attached to signal equipment (e.g. street lighting) must be given adequate notification to allow sufficient time for them to remove or maintain their work

Alter Elevation of Pole Foundation or Pull Boxes

When adjustments to existing pole foundations and pull boxes are specified, the poles or frames and covers shall be removed and the foundation (anchor bolts, conduits, ground wires, conductor cables, etc.) or walls

**ITEM 680.77XXX05 - MODIFY TRAFFIC SIGNAL INSTALLATION**  
**ITEM 680.79XXX05 - REMOVE TRAFFIC SIGNAL INSTALLATION**  
**ITEM 680.50XXX05 - ALTER ELEVATION OF POLE FOUNDATION**  
**ITEM 680.50500005 - REMOVE POLE FOUNDATION**  
**ITEM 680.51XXX05 - ALTER ELEVATION OF PULL BOXES**  
**ITEM 680.90000005 - RESET POLE**

reconstructed as required in the contract documents.

Remove Pole Foundations

Support poles are to be removed in their entirety to permit reuse by the owner. Anchor base poles shall be removed from the foundation and the foundation shall be cut one foot below final grade surface or subgrade, whichever is lower, unless the foundation interferes with the construction and will have to be removed in order to complete the work. Embedded poles shall be removed in their entirety (including all foundation materials from around the pole) unless it is determined by the Engineer that such removal will cause damage to existing underground facilities. If the Engineer orders the Contractor in writing to leave an embedded pole foundation in place, the pole and foundation shall be cut one foot below finished grade or subgrade, whichever is lower.

Holes

All holes resulting from this work shall be backfilled with suitable material and if so specified the disturbed areas restored to match the adjacent surface as approved by the Engineer.

**METHOD OF MEASUREMENT:**

Each

The following items will be measured for payment as the number of each operation completed in accordance with the contract documents to the satisfaction of the Engineer.

680.50XXX05 - Alter Elevation of Pole Foundation  
680.51XXX05 - Alter Elevation of Pull Boxes  
680.90000005 – Reset Pole

Foot

The following item will be measured for payment as the number of feet of pole foundation removed measured (to the nearest one half foot) from the top of anchor bolts, for anchor base poles, and the top of concrete, for embedded poles, to the depth of removal.

680.50500005 - Remove Pole Foundation.

Each Location

The quantity for each location includes all the work described in the contract documents for each serialized pay item. The following items will be measured for payment as the number of locations completed in accordance with the contract documents to the satisfaction of the Engineer.

680.77XXX05 - Modify Traffic Signal Installation  
680.79XXX05 - Remove Traffic Signal Installation

**BASIS OF PAYMENT:**

The requirements of Standard Specifications Section 680-5.01, General shall apply with the following



**ITEM 680.77XXX05 - MODIFY TRAFFIC SIGNAL INSTALLATION**  
**ITEM 680.79XXX05 - REMOVE TRAFFIC SIGNAL INSTALLATION**  
**ITEM 680.50XXX05 - ALTER ELEVATION OF POLE FOUNDATION**  
**ITEM 680.50500005 - REMOVE POLE FOUNDATION**  
**ITEM 680.51XXX05 - ALTER ELEVATION OF PULL BOXES**  
**ITEM 680.90000005 - RESET POLE**

additional provisions:

Modify Traffic Signal Installation

The unit bid per location shall include all costs for grounding and the repairing or replacing of equipment damaged, destroyed or lost by the Contractor's operations or negligence. Installation of replacement equipment and materials supplied by the owning agency is also included unless provided for under other items.

Progress payments for each location will be made in the following manner:

Sixty-five percent of the bid price of each location modified will be paid after it is completed and ready for testing.

Twenty-five percent of the bid price will be paid after satisfactory completion of all tests required by these specifications, including the function test for ten days of continuous satisfactory operation of the traffic signal system at each location.

The remaining ten percent will be paid when all the traffic signals in the contract are functioning to the satisfaction of the Engineer.

Remove Traffic Signal Installation

The unit price bid for each location removed shall include the cost for removing, storing and/or disposing as indicated in the contract documents.

Progress payments for each location removed will be made in the following manner:

Sixty-five percent will be paid when the elements to be removed are taken down.

Twenty percent will be paid when the elements are disposed of off the job site or salvaged by the owning agency.

The remaining fifteen percent will be paid when the location is restored to the satisfaction of the Engineer.

Alter Elevation of Pull Boxes and Pole Foundations

The unit price bid for each alteration operation as specified in the contract documents shall include all costs for excavation, backfill, removing and/or cutting off concrete, reinforcing or anchor bolts, furnishing and installing concrete, bonding compounds, reinforcing bars, anchor bolt extensions and necessary drilling and grouting, removing, storing or resetting frames and grates and restoration of the site as specified. Removing and resetting poles made necessary by this work shall be paid for under their respective items.

Remove Pole Foundations

The unit price bid per foot of pole foundation removed shall include all costs for excavation and disposal, backfill, removing and/or cutting off reinforcing or anchor bolts and restoring the site if specified in the

**ITEM 680.77XXX05 - MODIFY TRAFFIC SIGNAL INSTALLATION**  
**ITEM 680.79XXX05 - REMOVE TRAFFIC SIGNAL INSTALLATION**  
**ITEM 680.50XXX05 - ALTER ELEVATION OF POLE FOUNDATION**  
**ITEM 680.50500005 - REMOVE POLE FOUNDATION**  
**ITEM 680.51XXX05 - ALTER ELEVATION OF PULL BOXES**  
**ITEM 680.90000005 - RESET POLE**

contract documents.

Reset Pole

The unit price bid for each pole reset shall include the cost for refurbishing, handling, erecting (including signs, push buttons, street lighting and other appurtenances if attached), furnishing anchor bolts (installed under another item) if required, field galvanizing, drag wires, conductor cable connection, grounding and incidental connecting hardware as specified. Removing the pole will be paid for under the item for Remove Traffic Signal Installation.

Payment will be made under:

<u>ITEM NO.</u>	<u>ITEM DESCRIPTION</u>	<u>PAY UNIT</u>
680.77XXX05	Modify Traffic Signal Installation Location _____	Each Location
680.79XXX05	Remove Traffic Signal Installation Location _____	Each Location
680.50000105	Alter Elevation of Pole Foundations Type 1	Each
680.50000205	Alter Elevation of Pole Foundations Type 2	Each
680.50000305	Alter Elevation of Pole Foundations Type 3	Each
680.50500005	Remove Pole Foundations	Foot
680.51000105	Alter Elevation of Pull Boxes Type 1	Each
680.51000205	Alter Elevation of Pull Boxes Type 2	Each
680.51000305	Alter Elevation of Pull Boxes Type 3	Each
680.90000005	Reset Pole	Each

**ITEM 680.51100010 - CLEAN EXISTING PULLBOX**

**DESCRIPTION:**

The Contractor shall clean existing pullboxes as indicated on the plans or as directed by the Engineer.

**MATERIALS:**

Not applicable.

**CONSTRUCTION DETAILS:**

Existing pullboxes shall be cleaned to the base of its walls in a workmanlike manner and maintained clean as determined by the Engineer for the duration of the contract.

Existing pullboxes shall be dried by pumping, bailing, hauling or by any other method approved by the Engineer. Drying operations shall not cause soil erosion and shall be performed so as to avoid contamination of other new or existing facilities.

Material removed from the pullboxes shall be disposed of in accordance with provisions of Subsection 203-3.08, Disposal of Surplus Excavated Materials.

The Contractor shall execute care and protect all facilities within the pullboxes and the area adjacent to the work.

The Contractor shall replace in kind, any pullboxes or other facilities damaged by his operations at his own expense.

**METHOD OF MEASUREMENT:**

Cleaning existing pullboxes will be measured by the number of pullboxes actually cleaned and maintained in accordance with the Contract Documents and as directed by the Engineer.

**BASIS OF PAYMENT:**

The unit price bid to clean each existing pullbox shall include the cost of furnishing all labor, materials, and equipment necessary to satisfactorily complete the work. Payment will be made for only those existing pullboxes designated by the Engineer to be cleaned. Only one payment for each existing pullbox will be made regardless of the number of times it is cleaned. No payments will be made for pullboxes which are installed by the Contractor under this contract. No separate payments will be made for pullboxes damaged by the Contractor's operations.

06/26/97M

**ITEM 680.78010005 - Alter Pullbox for Conduit(s)**

**DESCRIPTION**

The work shall consist of providing openings in an existing pullbox to facilitate the installation of new conduit(s).

**MATERIALS**

None

**CONSTRUCTION DETAILS**

The Contractor shall create the opening using industry accepted standards. The area around the conduit shall be sealed as shown on the standard sheets. The Contractor will be required to replace or repair, to the satisfaction of the Engineer, any equipment damaged or destroyed by the Contractors operations or negligence as determined by the Engineer.

**METHOD OF MEASUREMENT**

The work shall be measured as the number of pullboxes altered.

**BASIS OF PAYMENT**

The unit price bid for each altered pullbox shall include the cost of all equipment, labor and materials, to satisfactorily complete the work.

Conduit(s) will be paid for under its respective item.

**ITEM 680.82250101 - REMOVE PEDESTRIAN PUSHBUTTON AND SIGN ASSEMBLY**

**DESCRIPTION:**

Under this item, the Contractor shall remove pedestrian pushbutton and sign assemblies from existing traffic signal poles, pedestrian signal head poles, or pedestrian pushbutton and sign posts.

**MATERIALS:**

Not specified.

**CONSTRUCTION DETAILS:**

Under this item, the Contractor shall remove pedestrian pushbutton and sign assemblies from existing traffic signal poles, pedestrian signal head poles, or pedestrian pushbutton and sign posts at the locations indicated in the plans, or where ordered by the Engineer. Where the poles are to be reused, any holes caused by the removal shall be retapped when necessary and new screws and bolts shall be placed to fill the voids; larger holes shall either be tapped for insertion of threaded plugs or shall be welded shut and field galvanized as per Section 719-01, Galvanized Coatings and Repair Methods of the Standard Specifications. In locations where the assembly is located on a pedestrian pushbutton and sign post, the post shall be removed to below ground level and the surface shall be restored to match existing conditions. The material removed shall become the property of the Contractor and shall be removed from the site.

**METHOD OF MEASUREMENT:**

This work will be measured as the number of pedestrian pushbuttons and signs removed.

**BASIS OF PAYMENT:**

The unit price bid for each removal shall cover the cost of all labor, material, and equipment necessary to complete the work.

**ITEM 680.82250108 - RELOCATE PEDESTRIAN PUSHBUTTONS AND SIGNS**

**ITEM 680.82250208 - REMOVE AND STORE PEDESTRIAN PUSHBUTTONS AND SIGNS**

**ITEM 680.82250308 - REMOVE AND DISPOSE PEDESTRIAN PUSHBUTTONS AND**

**SIGNS**

**ITEM 680.82250408 - RELOCATE PEDESTRIAN POLE**

**ITEM 680.82250508 - REMOVE AND STORE PEDESTRIAN POLE**

**ITEM 680.82250608 - REMOVE AND DISPOSE PEDESTRIAN POLE AND FOUNDATION**

**DESCRIPTION:**

This work shall consist of relocating, removing, storing and/or disposing, refurbishing, or replacing of elements of a pedestrian traffic signal system in accordance with the plans, specifications or as directed by the Engineer.

Where not specifically covered in the contract documents, the work shall be in accordance with the latest national, local and industrial standards or codes which are usually applied to such work, and the requirements of the maintaining agency.

**MATERIALS:**

When an existing system is to be relocated, the existing material shall be reused in the revised system, removed, salvaged, or disposed of as shown on the plans, as specified in the special provisions, or as directed by the Engineer. When new materials must be provided under the modification work, they shall conform to the material requirements of Section 680-2 whenever applicable. Materials not specified in 680-2 shall match the existing system as nearly as possible, and meet the requirements of the owning agency and/or as approved by the Engineer.

**CONSTRUCTION DETAILS:**

The applicable provisions of Subsection 680-3, Construction Details shall be complied with in addition to the following:

Removing and Salvaging

Care shall be exercised in removing signal and electrical equipment and any appurtenances attached to them so that elements to remain or be salvaged will not be damaged.

The contractor will be required to replace or repair, to the satisfaction of the Engineer, any equipment damaged, destroyed or lost due to the contractor's operations or negligence as determined by the Engineer.

Existing equipment or material intended to be reused and found to be missing or unsatisfactory, through no fault of the contractor, shall be properly replaced by the contractor, using equipment or material supplied by the owning agency or under other items.

**ITEM 680.82250108 - RELOCATE PEDESTRIAN PUSHBUTTONS AND SIGNS**  
**ITEM 680.82250208 - REMOVE AND STORE PEDESTRIAN PUSHBUTTONS AND SIGNS**  
**ITEM 680.82250308 - REMOVE AND DISPOSE PEDESTRIAN PUSHBUTTONS AND**  
**SIGNS**

**ITEM 680.82250408 - RELOCATE PEDESTRIAN POLE**  
**ITEM 680.82250508 - REMOVE AND STORE PEDESTRIAN POLE**  
**ITEM 680.82250608 - REMOVE AND DISPOSE PEDESTRIAN POLE AND FOUNDATION**

All equipment or materials specified for removal but not intended to be incorporated in the new or modified system shall be removed from the site and disposed of as specified in the contract documents and/or as directed by the Engineer.

Removing Pole Foundations

Pedestrian poles are to be removed in their entirety to permit reuse by the owner. Poles shall be removed from the foundation and the foundation shall be cut 2 ft. below final grade or subgrade, whichever is lower, unless the foundation interferes with the construction and will have to be removed in order to complete the work.

Holes

All holes resulting from this work shall be backfilled with suitable material and if so specified the disturbed areas restored to match the adjacent surface as approved by the Engineer.

**METHOD OF MEASUREMENT:**

Each Unit

The quantity to be paid for under this item(s) will be the number of pedestrian signal system elements actually relocated, removed, stored and/or disposed of as shown on the plans or in the contract documents.

**BASIS OF PAYMENT:**

The requirements of Subsection 680-5.01 General shall apply with the following additional provisions:

RELOCATE PEDESTRIAN PUSHBUTTONS AND SIGNS  
REMOVE AND STORE PEDESTRIAN PUSHBUTTONS AND SIGNS  
REMOVE AND STORE PEDESTRIAN POLE

The unit price bid per each shall include all costs for removal of any conduit riser on wooden poles to nearest pullbox, removal of cable to nearest pullbox or as shown on plans or as directed by the Engineer, and the repairing or replacing of equipment damaged, destroyed, or lost by the Contractor's operations or negligence. Installation of replacement equipment and materials supplied by the owning agency is also included unless noted for payment under other items.

**ITEM 680.82250108 - RELOCATE PEDESTRIAN PUSHBUTTONS AND SIGNS**

**ITEM 680.82250208 - REMOVE AND STORE PEDESTRIAN PUSHBUTTONS AND SIGNS**

**ITEM 680.82250308 - REMOVE AND DISPOSE PEDESTRIAN PUSHBUTTONS AND  
SIGNS**

**ITEM 680.82250408 - RELOCATE PEDESTRIAN POLE**

**ITEM 680.82250508 - REMOVE AND STORE PEDESTRIAN POLE**

**ITEM 680.82250608 - REMOVE AND DISPOSE PEDESTRIAN POLE AND FOUNDATION**

RELOCATE PEDESTRIAN POLE

The unit price for each pole reset shall include the cost for removing the pole from the existing foundation, refurbishing, handling, erecting (including signs, push buttons, and other appurtenances if attached), furnishing anchor bolts (installed under another item) if required, field galvanizing, drag wires, conductor cable connection, grounding and incidental connecting hardware as specified. The cost of the new foundation, including excavation shall be paid for under their respective items

REMOVE AND DISPOSE PEDESTRIAN PUSHBUTTONS AND SIGNS

REMOVE AND DISPOSE PEDESTRIAN POLE AND FOUNDATION

The unit price bid per each shall include all costs for removal of any conduit riser on wooden poles to nearest pullbox, removal of cable and conduit to nearest pullbox or as shown on plans or as directed by the Engineer



## **ITEM 680.82250201 - REMOVE PEDESTRIAN SIGNAL ASSEMBLIES**

### **DESCRIPTION:**

Under this item, the Contractor shall remove pedestrian signal head assemblies from existing traffic signal or pedestrian signal head poles.

### **MATERIALS:**

Not specified.

### **CONSTRUCTION DETAILS:**

Under this item, the Contractor shall remove pedestrian signal heads and all associated fittings and conduits from existing traffic signal or pedestrian signal head poles at the locations indicated in the plans, or when ordered by the Engineer. Where the poles are to be reused, any holes caused by the removal shall be retapped when necessary and new screws and bolts shall be placed to fill the voids; larger holes shall either be tapped for insertion of threaded plugs or shall be welded shut and field galvanized as per Section 719-01, Galvanized Coatings and Repair Methods of the Standard Specifications. The pedestrian signal heads and associated fittings and conduits removed are to be delivered to the New York State Department of Transportation Traffic Signal Maintenance Shop located in Waterford, New York.

### **METHOD OF MEASUREMENT:**

This work will be measured as the number of pedestrian signal heads removed from existing traffic signal or pedestrian signal head poles. Where two pedestrian signal heads are mounted on a single post-top bracket, two removals shall be paid for.

### **BASIS OF PAYMENT:**

The unit price bid for each pedestrian head assembly to be removed shall cover the cost of all labor, material and equipment

**ITEM 680.8225XY10 - RECTANGULAR RAPID FLASHING BEACON (RRFB)**  
**ASSEMBLY**

**1.0 DESCRIPTION**

This work shall consist of furnishing and installing a Rectangular Rapid Flashing Beacon (RRFB) assembly in accordance with the contract documents or as directed by the Engineer. All materials and labor required to provide a complete functioning system are to be included.

**1.1 General Requirements**

- 1.1.1 RRFB unit shall consist of two rapidly flashed, rectangular-shaped yellow indications with an LED-array-based light source. It shall be designed, located, and operated in accordance with the detailed requirements of the contract and as specified below.
- 1.1.2 Each RRFB shall conform to all provisions of the MUTCD.
- 1.1.3 Each RRFB shall be a complete assembly consisting of supporting structure (pole, breakaway transformer base, sign, cabinet, and solar panel supports), indications, signage, cabinet, solar panel, and electrical components (wiring, solid-state circuit boards, etc.).
- 1.1.4 Each RRFB shall be supplied with all required hardware to install assembly.
- 1.1.5 Each RRFB shall be ADA compliant.
- 1.1.6 Each RRFB shall be rated for 90 mph wind conditions.
- 1.1.7 All components shall be designed to operate under ambient temperature conditions from -30 to 165 °F.

**1.2 Functional Requirements**

- 1.2.1 The RRFB shall be normally dark, shall initiate operation only upon pedestrian actuation, and shall cease operation after a predetermined period of operation. The predetermined period of operation shall be based on the procedures provided in Section 4E.06 of the current MUTCD for the timing of pedestrian clearance times for pedestrian signals.
- 1.2.2 When actuated, all RRFB units associated with a given crosswalk shall simultaneously commence operation of their rapid-flashing indications within 120 milliseconds. All RRFB units associated with a given crosswalk shall simultaneously cease operation of their rapid-flashing indications within 120 milliseconds.
- 1.2.3 During activation, a small light, directed at and visible to pedestrians in the crosswalk, shall be installed integral to the RRFB to give confirmation that the RRFB is in

**ITEM 680.8225XY10 - RECTANGULAR RAPID FLASHING BEACON (RRFB)**  
**ASSEMBLY**

operation. The pedestrian indication shall flash concurrently with one of the vehicle indications to give confirmation that the RRFB is in operation.

- 1.2.4 Upon actuation, the two or four yellow indications in each RRFB unit shall flash in a sequence of 75 cycles per minute. The left and right RRFB indications shall operate using the following sequence during each 800-millisecond cycle:

The RRFB indication on the left-hand side shall be illuminated for approximately 50 milliseconds.

Both RRFB indications shall be dark for approximately 50 milliseconds.

The RRFB indication on the right-hand side shall be illuminated for approximately 50 milliseconds.

Both RRFB indications shall be dark for approximately 50 milliseconds.

The RRFB indication on the left-hand side shall be illuminated for approximately 50 milliseconds.

Both RRFB indications shall be dark for approximately 50 milliseconds.

The RRFB indication on the right-hand side shall be illuminated for approximately 50 milliseconds.

Both RRFB indications shall be dark for approximately 50 milliseconds.

Both RRFB indications shall be illuminated for approximately 50 milliseconds.

Both RRFB indications shall be dark for approximately 50 milliseconds.

Both RRFB indications shall be illuminated for approximately 50 milliseconds.

Both RRFB indications shall be dark for approximately 250 milliseconds.

- 1.2.5 The flash rate of each individual RRFB indication, as applied over the full flashing sequence, shall not be between 5 and 30 flashes per second to avoid frequencies that might cause seizures in anyone viewing the activated RRFB.

- 1.2.6 The light intensity of the yellow indications during daytime conditions shall meet the minimum specifications for Class 1 yellow peak luminous intensity in the current Society of Automotive Engineers (SAE) Standard J595 (Directional Flashing Optical Warning Devices for Authorized Emergency, Maintenance, and Service Vehicles).

**ITEM 680.8225XY10 - RECTANGULAR RAPID FLASHING BEACON (RRFB)**  
**ASSEMBLY**

- 1.2.7 To minimize excessive glare, an automatic signal dimming device shall be used to reduce the brilliance of the RRFB indications during nighttime conditions.

## **2.0 MATERIALS**

All provisions of §709-01, §715, §723, §724 and §730 shall apply except as detailed below:

### **2.1 Indicators:**

- 2.1.1 Each RRFB facing shall consist of two rectangular-shaped yellow indications each with an LED-array-based light source. The size of each RRFB indication shall be at least 5 inches wide by at least 2 inches high and shall be aligned horizontally, with the longer dimension horizontal and with a minimum space between the two indications of at least 7 inches, measured from the nearest edge of one indication to the nearest edge of the other indication.
- 2.1.2 The outside edges of the RRFB indications, including any housings, shall not project beyond the outside edges of the signage of the RRFB.
- 2.1.3 Indicators shall be mounted in a housing constructed of durable, corrosion resistant, powder-coated aluminum with stainless steel fasteners.
- 2.1.4 Mounting hardware shall be stainless steel.
- 2.1.5 The indicator housing shall be located between and immediately adjacent to the bottom of the crossing warning sign and the top of the supplemental downward diagonal arrow plaque (or, in the case of a supplemental advance sign, the AHEAD or distance plaque).
- 2.1.6 All RRFB light bars shall be field adjustable to maximize the field of view on each vehicle approach.
- 2.1.7 Shall be rated for a minimum 15-year life span.

### **2.2 Radio Network Controller and Cabinet:**

- 2.2.1 The local equipment controlling the components of the beacon assembly shall be housed in a lockable, weatherproof, vandal and tamper resistant NEMA 3R rated aluminum enclosure, intended for outdoor use, primarily to provide a degree of protection against corrosion, windblown dust and rain, splashing water, hose-directed water, and damage from ice formation.
- 2.2.2 The cabinet shall be mounted on the pole and a work pad shall be provided, in accordance with signal system details. Cabinet shall not intrude into sidewalk or obstruct the pedestrian push button.
- 2.2.3 The cabinet shall be mounted on the side of the pole away from approaching traffic at a height between 3.5 – 4.5 feet from the bottom of the cabinet to the ground. In unpaved areas a concrete work pad shall be installed in front of the cabinet door not to exceed 5 feet by 5 feet by 4 inches deep and shall abut the pole foundation.

**ITEM 680.8225XY10 - RECTANGULAR RAPID FLASHING BEACON (RRFB)**  
**ASSEMBLY**

- 2.2.4 The cabinet shall be of sufficient size to house all required equipment.
- 2.2.5 Cabinet locking mechanisms shall meet NYSDOT standards currently used by the regional traffic signal groups. All keys to installed locking mechanisms shall be supplied to the Engineer upon acceptance of the work. The cabinet shall be secured with a Corbin lock and keyed as directed by the Regional Traffic Engineer for securing the cabinet door.
- 2.2.6 The controller shall be replaceable independently of other components.

**2.3 Controls:**

- 2.3.1 Controls shall include integrated constant current LED drivers with a minimum of two output channels for driving one or two assemblies.
- 2.3.2 Controls shall be completely programmable:
  - 2.3.2.1 To run for a user specified time period when activated via switch, button contact closure, or when triggered from an external sensor such as a wireless transmitter, radar detector, presence detector, or wireless walk through bollard with a compatible sensor output.
- 2.3.3 Controls shall be capable of being programmed for alternate flash rates and patterns with a minimum resolution of 0.25s per trigger action.
- 2.3.4 Controls shall seamlessly integrate with the wireless transceiver to form a network of connected devices.
- 2.3.5 Controls shall allow adjustable and programmable light intensity levels for the beacons. Intensity level programming shall allow for manual and automatic modes. Manual mode shall allow the light intensity to be configured for a constant output on every available intensity level. Automatic mode shall allow for automatic intensity adjustment based upon assembly's ambient light conditions. Assemblies shall have a minimum of two brightness intensities available, exclusive of any unlit condition.
- 2.3.6 Controls shall include data-logging capabilities with selectable interval from one minute to one day with at least a 60-day logging period.
- 2.3.7 Controls shall include an RS232 serial interface and ethernet interface for local programming. Controls may include USB cable interfaces for supplemental data connections.
- 2.3.8 Controls shall be locally programmable using software for Microsoft Windows 2007 or later or web based program.
- 2.3.9 The controller software shall allow programmable operation of the Assembly. Direct control of functions such as lighting controls shall be possible.

**2.4 Transceiver:**

- 2.4.1 Shall provide wireless communication between the assemblies to integrate the

**ITEM 680.8225XY10 - RECTANGULAR RAPID FLASHING BEACON (RRFB)**  
**ASSEMBLY**

- pushbutton activation of indications.
- 2.4.2 Shall seamlessly integrate with the controller to ensure sequential activation of other radio-equipped devices in the system.
- 2.4.3 Shall synchronize the system components to activate the indications within 120 ms of one another and remain synchronized throughout the duration of the flash (timeout) cycle.
- 2.4.4 Shall include network-wide modification of sign controller settings and output durations using programmability from any networked transceiver without the use of additional equipment or software.
- 2.4.5 Shall be capable of operating as a parent (gateway) or child (node or repeater).
- 2.4.6 Shall be capable of providing site-survey data for verification of signal strength between network devices.
- 2.4.7 Shall operate on the license-free ISM band.
- 2.4.8 Radio control shall operate on an FCC approved 900 MHz frequency, hopping spread spectrum network with a normal operating range of ~1000 feet.
- 2.4.9 Shall operate from 3.3 to 15 VDC input.
- 2.4.10 Shall comply with 47 CFR Part 15.
- 2.4.11 Shall be replaceable independently of other components.
- 2.4.12 The product must be FCC certified to comply with all 47 CFR Part 15 Subpart B Emission requirements.

**2.5 Emergency Shutoff:**

- 2.5.1 One toggle-type power switch, for either the AC or solar power source, shall be provided for emergency shutoff at the local cabinet on the pole.

**2.6 Power Supply:**

- 2.6.1 The power supply shall be either solar or 120 VAC and meet all applicable codes.
- 2.6.2 With the exception of conduits run for service entrance cables as detailed in NFPA 70: National Electric Code, the assembly shall contain no externally mounted wiring or wiring conduits.
- 2.6.3 Autonomy with a fully charged battery shall be at least 30 days of continuous operation without charging at an ambient temperature of 70 °F with at least ten actuations per hour.
- 2.6.4 Battery:
  - 2.6.4.1 Shall have a nominal output voltage of 12 VDC and a capacity of 48 Ah at a C100 discharge rate.
  - 2.6.4.2 Shall be sealed and spill proof.
  - 2.6.4.3 Shall have terminals that accept screws or bolts for secure wiring connections.
  - 2.6.4.4 Shall be replaceable independently of other components.

**ITEM 680.8225XY10 - RECTANGULAR RAPID FLASHING BEACON (RRFB)**  
**ASSEMBLY**

2.6.4.5 Shall be fused for short circuit protection.

**2.7 Solar Power:**

- 2.7.1 One solar array with a bracket for mounting to the top of the pole.
- 2.7.2 Flexible, liquid tight conduit shall be used from the solar panel to the weather head/pole cap or as instructed by the solar panel manufacturer's instructions.
- 2.7.3 The solar panel shall be affixed to an aluminum plate and bracket, adjustable at an angle of 45 – 60 degrees to facilitate adjustment for maximum solar collection and optimal battery strength.
- 2.7.4 The solar panel assembly (panel, plate and bracket) shall be secured to a pole cap mount, capable of 360-degree rotation, to facilitate adjustment for maximum solar collection and optimal battery strength.
- 2.7.5 The solar panel shall be capable of withstanding operating temperatures of -30 to 165 °F.
- 2.7.6 If an Accessible Pedestrian Signal (APS) system is called for in the contract documents, all provisions for the continuous operation of the APS will be accounted for in the solar power system.
- 2.7.7 Solar Charge Controller:**
  - 2.7.7.1 Shall automatically provide Low Voltage Disconnect (LVD) to protect diminished power batteries.
  - 2.7.7.2 Shall automatically provide Load-Reconnection once battery levels have been restored to an acceptable power level.
  - 2.7.7.3 Shall protect against and automatically recover from short circuits, overloads, reverse polarities, high temperatures, lightning and transient surges, and voltage spikes.
  - 2.7.7.4 Shall be independently replaceable of other control panel components.

**2.8 Electrical Power:**

- 2.8.1 The AC input terminals shall be equipped with a 210 J (joule) capacity power line surge suppressor. The suppressor shall have noise blanking capability.
- 2.8.2 Where required by the contract documents, or as required by the utility company, a meter shall be included.
- 2.8.3 All electrical components and wiring shall be approved to CSA or UL standards as applicable.
- 2.8.4 AC Power shall have electrical service disconnect.

**2.9 Pole Shaft:**

- 2.9.1 Shall be a standard 4.5-inch OD galvanized steel pole as per §724 with 4 bolt base plate with a 12.75-inch bolt circle.
- 2.9.2 Shall meet MUTCD height requirements.

**ITEM 680.8225XY10 - RECTANGULAR RAPID FLASHING BEACON (RRFB)**  
**ASSEMBLY**

**2.10 Pole Pedestal Base:**

- 2.10.1 Shall conform to §723-15 and mount on a concrete foundation attached by four anchor 'J' bolts that are to be imbedded in a concrete foundation.
- 2.10.2 Shall meet or exceed AASHTO break-away requirements for traffic signal supports.

**2.11 Pedestrian Push Buttons:**

- 2.11.1 A piezo pushbutton shall be ADA compliant, and shall operate as normally open (n/o) circuit.

**2.12 Static Signs:**

- 2.12.1 All signs shall conform to the MUTCD and the NYS Supplement to the MUTCD.
- 2.12.2 All sign panels and plaques shall conform to the requirements of §645-2.02 of the NYS Standard Specifications.
- 2.12.3 Sign sheeting shall conform to the requirements in §645-2.02.
- 2.12.4 All sign assemblies shall use anti-vandal fasteners and tools to mount components to sign and sign to fixture.
- 2.12.5 Crossing sign assemblies shall consist of one of the following with the appropriate plaque: Pedestrian Crossing (W11-2), a School Crossing (S1-1), or a Trail Crossing (W11-15).
- 2.12.6 R10-25 shall be furnished, at least a size of 9 by 12 inches, to be mounted adjacent to and above each pedestrian pushbutton.

**3.0 CONSTRUCTION DETAILS**

- 3.1 All provisions of §645 and §680 shall apply except for all electrical wiring and as modified below.
- 3.2 Electrical and communication wires shall be run in separate conduits.
- 3.3 Prior to any fabrication or installation of any of the components of the Flashing Beacon Assembly, the Contractor shall submit detailed specifications, parts lists, manufacturer's cut sheets, instruction sheets, and wiring diagrams to the Engineer for approval at least 14 calendar days before installation.
- 3.4 The Contractor shall install and position the beacon assembly in such a manner as to optimize visibility for roadway traffic, and optimize incident light for the solar assembly, using the manufacturer's recommendations and instructions for installation.



**ITEM 680.8225XY10 - RECTANGULAR RAPID FLASHING BEACON (RRFB)**  
**ASSEMBLY**

3.5 If the Engineer determines that the unit is not functioning properly, the Contractor shall secure the services of the manufacturer's representative for installation and testing.

3.6 Where new work is to meet existing infrastructure, the Contractor's methods shall provide for neat lines, to achieve a satisfactory installation.

**4.0 METHOD OF MEASUREMENT**

This work will be measured as the number of RRFB assemblies furnished and installed in accordance with the Contract Documents, or as directed by the Engineer.

**5.0 BASIS OF PAYMENT**

5.1 The unit price bid shall include the cost of furnishing all labor, materials, and equipment necessary to satisfactorily complete the work, including the signs shown in the associated details.

5.2 Note:

X= 2 = two forward beacons,

4 = four beacons, two forward facing beacons, and two rearward facing beacons;

Y= 1 = AC powered (overhead supply),

2 = AC powered (underground supply),

3 = Solar powered

2 OR 4 - AMBER LED SIGNAL INDICATIONS

**TOP VIEW**

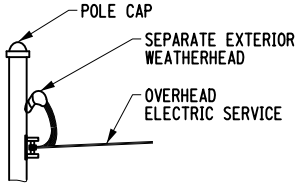

**OVERHEAD ELECTRICAL (120V) SERVICE DETAIL OPTION**

(SEE DETAIL ON SHEET 2 AND NOTE 9 ON SHEET 3)

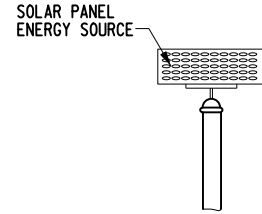

**SOLAR PANEL DETAIL OPTION**

SEE OVERHEAD ELECTRICAL (120V) SERVICE & SOLAR PANEL DETAIL OPTIONS ON THIS SHEET

W16-7P SUPPLEMENTAL SIGN (SEE NOTES 4 ON SHEET 3)

FOR ELECTRICAL (120V) SERVICE OPTIONS: METER PAN (SEE DETAIL ON SHEET 2 AND NOTE 9 ON SHEET 3)

FOR ELECTRICAL (120V) SERVICE OPTIONS: WATERTIGHT DISCONNECT BOX (SEE DETAIL ON SHEET 2 AND NOTE 9 ON SHEET 3)

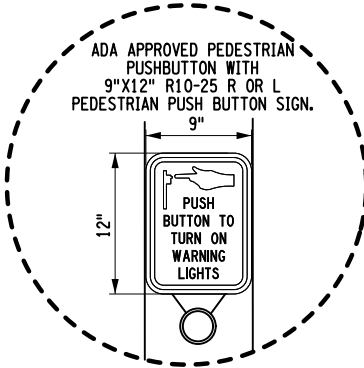

GALVANIZED STEEL SIGNAL POLE (SEE NOTE 11 ON SHEET 3)

GROUND TERMINAL

BREAKAWAY TRANSFORMER BASE (SEE NOTE 11 ON SHEET 3)

POLE-MOUNTED RADIO NETWORK CONTROLLER WITH WORK PAD (SEE NOTE 8 ON SHEET 3)

(SEE NOTE 8 ON NYSDOT STANDARD SHEET 645-03)

GROUNDWIRE (SEE NOTE 10 ON SHEET 3)  
NUMBER AND SIZE OF CONDUIT AS SPECIFIED ON THE PLANS

CONCRETE FOUNDATION (SEE NOTE 11 ON SHEET 3)

**FRONT VIEW**

SEE NOTES ON SHEET 3 OF 3

SHEET 1 OF 3

ALL DIMENSIONS ARE IN FT UNLESS OTHERWISE NOTED



**Department of Transportation**

ITEM 680.8225XY10- RECTANGULAR RAPID FLASHING BEACON (RRFB) ASSEMBLY

FILE NAME = PED\_X\_SIGNAL\_CPEG.V.3.DGN  
DATE/TIME = 28-OCT-2021 09:48  
USER = rfoote

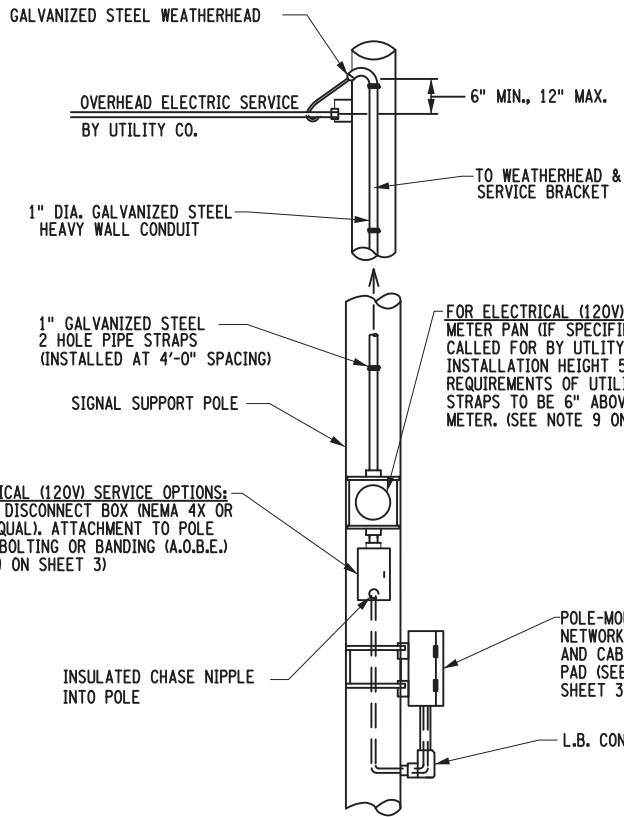

**OVERHEAD ELECTRICAL SERVICE DETAIL  
(POLE MOUNTED CABINET)**

(NOT TO SCALE)

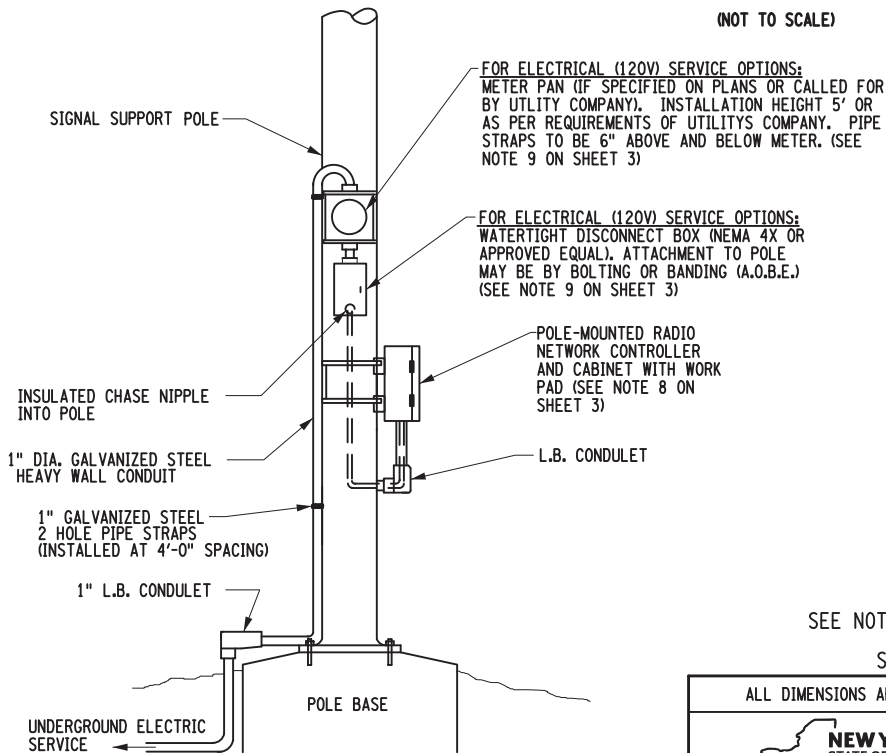

**UNDERGROUND ELECTRICAL SERVICE DETAIL  
(POLE MOUNTED CABINET)**

(NOT TO SCALE)

SEE NOTES ON SHEET 3 OF 3

SHEET 2 OF 3

ALL DIMENSIONS ARE IN FT UNLESS OTHERWISE NOTED



**Department of  
Transportation**

ITEM 680.8225XY10- RECTANGULAR RAPID FLASHING BEACON (RRFB) ASSEMBLY

FILE NAME = PED\_X\_SIGNAL\_CPFG\_V.2.DSN  
DATE/TIME = 29-JUN-2018 14:36  
USER = wdevies

NOTES:

1. NOTIFY DIG SAFELY - NEW YORK AT (800) 962-7962 PRIOR TO ANY EXCAVATION.
2. WIDTH OF SOLAR PANEL AND LED SIGNAL INDICATION ASSEMBLY SHALL NOT EXCEED THE WIDTH OF SIGN PANEL.
3. WHEN MULTIPLE UNITS ARE USED AT A LOCATION CONTRACTOR SHALL USE DIFFERENT RADIO FREQUENCIES TO AVOID COMMUNICATION ISSUES.
4. SEE CONTRACT DOCUMENTS FOR THE TYPE(S) AND LOCATION(S) OF PROPOSED RRFB ASSEMBLIES . IN THE ITEM NUMBER:

X INDICATES IF IT IS A FORWARD FACING ASSEMBLY ONLY OR FORWARD AND REARWARD FACING (BACK-TO-BACK) ASSEMBLY WHERE:

X=2 A FORWARD FACING ASSEMBLY CONSISTING OF 2 AMBER LED BEACON INDICATIONS WITH 1-W11-2 OR S1-1 OR W11-15 CROSSING SIGN AND 1-W16-7P SUPPLEMENTAL SIGN.

X=4 FOR A FORWARD AND REARWARD FACING (BACK-TO-BACK) ASSEMBLY CONSISTING OF 4 AMBER LED BEACON SIGNAL INDICATIONS (TWO FORWARD FACING AND TWO REARWARD FACING) WITH 2-W11-2 OR S1-1 OR W11-15 CROSSING SIGNS AND 2-W16-7P SUPPLEMENTAL SIGNS (ONE SET OF EACH FACING FORWARD AND REARWARD),

Y IS METHOD OF PROVIDING ELECTRICAL SERVICE WHERE:

Y=1 FOR OVERHEAD ELECTRICAL SERVICE

Y=2 FOR UNDERGROUND ELECTRICAL SERVICE.

Y=3 FOR SOLAR POWER

SEE DETAILS ON SHEET FOR ADDITIONAL REQUIREMENTS.

5. CROSSING SIGNS AND SUPPLEMENTAL PLAQUES SHALL UTILIZE FLUORESCENT YELLOW-GREEN TYPE IX SHEETING. SIGN AND PLAQUE SIZES SHALL CONFORM TO THE MUTCD. ALL SIGNS AND PLAQUES SHALL CONFORM TO THE MATERIAL REQUIREMENTS IN SECTION 645 OF THE STANDARD SPECIFICATIONS.
6. WHEN USED IN PAIRS/SET (SUCH AS ON BOTH TERMINUS POINT OF A CROSSWALK) ACTIVATION OF ONE SHALL ACTIVATE THE OTHER(S) IN THE SET/SYSTEM.
7. POLE PENETRATING MOUNTING DEVICES (RELATING TO LIGHTS, SIGNS, CABINETS, CONDUITS, CLAMPS, BUTTONS, ETC.) SHALL NOT SIGNIFICANTLY DEGRADE THE INTEGRITY OF THE SIGNAL POLE.
8. THE POLE-MOUNTED RADIO NETWORK CONTROLLER CABINET SHALL NOT INTRUDE INTO THE SIDEWALK AREA OR OBSTRUCT THE PEDESTRIAN PUSHBUTTON. THE CABINET SHALL BE MOUNTED ON THE SIDE OF THE POLE AWAY FROM APPROACHING TRAFFIC AT A HEIGHT BETWEEN 3.5-4.5 FROM THE BOTTOM OF THE CABINET TO THE FINISHED GROUND SURFACE. IN UNPAVED AREAS A CONCRETE WORK PAD SHALL BE CONSTRUCTED IN FRONT OF THE CABINET DOOR (AOBE) NOT TO EXCEED 5'X5'X4" DEEP AND SHALL ABUT AND BE FLUSH WITH THE POLE FOUNDATION. THE CABINET SHALL BE OF SUFFICIENT SIZE TO HOUSE ALL REQUIRED EQUIPMENT.
9. ELECTRICAL SERVICE MAY ALSO BE PROVIDED UNDERGROUND AND ENTER THROUGH THE BASE AS SPECIFIED ON THE PLANS. WHERE ELECTRICAL SERVICE IS PROVIDED OVERHEAD, THE POLE HEIGHT SHALL BE AS NECESSARY TO ACHIEVE MINIMUM SERVICE CABLE CLEARANCES AND/OR AVOID CONFLICTS. SEE DETAILS ON SHEET 1 & 2 FOR ADDITIONAL REQUIRMENTS.
10. SEE NOTES 3.6 & 3.7 ON STANDARD SHEET 680-04 FOR ADDITIONAL GROUNDING REQUIREMENTS.
11. THIS ASSEMBLY SHALL INCLUDE A GALVINIZED STEEL POLE WITH AN APPROVED BREAKAWAY TRANSFORMER BASE AND CONCRETE FOUNDATION MEETING ALL THE MATERIAL REQUIREMENTS OF STANDARD SPECIFICATION SECTION 680-2 AND BE SUITABLE TO HANDLE THE STATIC & DYNAMIC LOADING OF THE ASSEMBLY AS PER MANUFACTURER REQUIREMENTS. FOR FOUNDATION REINFORCEMENT, SEE STANDARD SHEET FOR TRAFFIC SIGNAL POLE FOUNDATIONS, CODE J-2.

SHEET 3 OF 3

ALL DIMENSIONS ARE IN FT UNLESS OTHERWISE NOTED



**Department of  
Transportation**

ITEM 680.8225XY10- RECTANGULAR RAPID FLASHING  
BEACON (RRFB) ASSEMBLY

FILE NAME = PED\_X\_SIGNAL\_CPFG\_V.2.DGN  
DATE/TIME = 29-JUN-2018 14:37  
USER = wdevies

**ITEM 680.90920008 - ELECTRIC METER SOCKET, 200 AMP, SINGLE PHASE,  
240/120 VOLT W/ BYPASS SWITCH FOR SIGNAL  
INSTALLATIONS**

**DESCRIPTION**

The Contractor shall furnish and install electric meter sockets for traffic signal installations with a lever operated bypass switch where shown on the plans or where directed by the Engineer.

**MATERIALS**

All materials shall be approved by the local electrical utility company.

The electric meter socket shall be a 200 ampere, 240/120 volt, 4-terminal, ringless with a lever operated bypass switch, single phase 3 wire, lay-in type with line and load connectors sized for #6 AWG wire gauge.

**CONSTRUCTION DETAILS**

The meter box assembly shall be installed in-line with the service entrance, positioned and mounted according to the utility specifications, and properly grounded.

All work shall be done in a manner satisfactory to the Engineer-In-Charge and the utility company.

**METHOD OF MEASUREMENT**

This work will be measured as the number of meter box installations made in accordance with the plans and accepted by the Engineer-In-Charge.

**BASIS OF PAYMENT**

The unit price bid for this item shall include the cost of furnishing all labor, material and equipment necessary to complete the work.

**ITEM 680.93510008 - GPS TIME SYNCHRONIZATION ANTENNA AND INTERFACE MODULE**

**DESCRIPTION**

This work shall consist of furnishing and installing Global Positioning System (GPS) time synchronization interface module and antenna system in accordance with the contract documents and as directed by the Engineer.

**MATERIALS**

The GPS time synchronization system shall consist of a programmable GPS interface module, GPS antenna, antenna cable, interface to controller cable and power cable. The system shall be designed to reset the clock time for 179, 2070 or NEMA type traffic signal controllers using a reference signal from the GPS system. The components of the system shall meet the following requirements:

**GPS Antenna**

Tamperproof and vandal resistant  
UV resistant materials

**GPS interface Module**

Temperature Rating: 165° F to -30° F  
Input Voltage: 6-30 VDC  
Solid-State construction

**CONSTRUCTION DETAILS**

The GPS antenna shall be designed to mount on the exterior of a traffic signal cabinet via a single hole. The GPS antenna case shall be made of a vandal resistance long life exterior grade UV resistant plastic. The GPS antenna mount shall include a suitable gasket or gasket material to ensure a raintight and secure connection between the antenna unit and the traffic signal cabinet. The contractor shall clean the exterior surface of the cabinet thoroughly prior to installing the GPS antenna gasket material.

The GPS interface module may be either a stand alone unit or rack mounted card. The stand alone unit shall be contained in a fully enclosed metal or plastic case which is suitable for wall mounting or shelf mounting inside a traffic signal controller cabinet. If the case is metal, it shall be bonded. The module shall be mounted so that it does not interfere with other equipment within the traffic signal controller cabinet. The rack mounted interface card shall be compatible with the traffic signal controller.

The GPS antenna shall be connected to the GPS interface module or rack mounted card via a single wiring cable. Any extra cable shall be neatly coiled and tied so as to not interfere with other equipment within the traffic signal controller cabinet. The cable shall be labeled.

**ITEM 680.93510008 - GPS TIME SYNCHRONIZATION ANTENNA AND INTERFACE MODULE**

The GPS interface module shall be connected to the traffic signal controller via a single controller specific wiring cable. Any extra cable shall be neatly coiled and tied so as to not interfere with other equipment within the traffic signal controller cabinet. The cable shall be labeled.

The contractor shall provide 2 copies of the user manual, installation instructions, and all product warranty documentation. The instructions shall include setup, maintenance information, troubleshooting, and error message guide. Parts list, circuit diagrams and service information shall also be included. The contractor shall also provide any software necessary to configure or test the system.

**METHOD OF MEASUREMENT**

This work will be measured as the number of GPS time synchronization interface module and antenna satisfactorily furnished and installed.

**BASIS OF PAYMENT**

The unit price bid shall include the cost of furnishing all labor, materials, and equipment necessary to satisfactorily complete the work.