

Jeffrey M. Lanigan
MAYOR



Jennifer Gleasman
PURCHASING AGENT

PURCHASING DEPARTMENT
ROME CITY HALL ♦ 198 N. WASHINGTON STREET
ROME, NEW YORK 13440-5815
(315) 339-7665
www.RomeNewYork.com

BID NUMBER: RFB - 2024 - 002
BID TITLE: SUPPLY AND DELIVER STEEL CASTINGS FOR STRUCTURES
BID DUE: MARCH 21, 2024 at 11:00 AM
BID OPENING: MARCH 21, 2024 at 11:00 AM

COMPANY NAME: EJ USA, Inc.

MAILING ADDRESS: 301 Spring Street, PO Box 439
East Jordan, MI, 49727

PHONE: 1-(800)-874-4100

EMAIL: us.bids@ejco.com

WEBSITE: ejco.com

SIGNATURE: 

PRINTED NAME/TITLE: Vice President & General Manager

TOTAL OF BID IN FIGURES: \$184,976.77

TOTAL OF BID IN WORDS: One Hundred Eighty Four Thousand, Nine Hundred Seventy-Six dollars and Seventy-Seven Centss

PROPOSER'S WARRANTY: The above-signed person by his/her affixed signature certifies that he/she is an officer of the organization. He/she has been specifically authorized to offer a proposal in full compliance with all requirements and conditions, as set forth in this Proposal, other than those deviations noted above. He/she has fully read and understands the Proposal and has full knowledge of the scope, nature, quantity, and quality of work to be performed and that he/she has carefully examined and checked the materials, equipment, labor, service, and cost thereof, and hereby states that the amount or amounts set forth in the proposal is or are correct. The bidder further agrees not to make claim for reformation, modification, or correction of this proposal after the scheduled closing time for receipt of proposal bids.



TABLE OF CONTENTS

<i>Page Title</i>	<i>Page No.</i>
<i>Cover Sheet of Bid Package</i>	<i>1</i>
<i>Table of Contents</i>	<i>2</i>
<i>Invitation and Instructions to Bid</i>	<i>3</i>
<i>General Conditions</i>	<i>4 – 8</i>
<i>General Municipal Law Compliance</i>	<i>9</i>
<i>Attention</i>	<i>10</i>
<i>Responsible Bidder</i>	<i>11</i>
<i>Non-Collusive Bidding Certificate</i>	<i>12</i>
<i>Technical Specifications</i>	<i>13</i>
<i>Bid Total Itemization Sheet</i>	<i>14</i>



INVITATION AND INSTRUCTIONS TO BID

The City of Rome, New York invites your firm to participate in the enclosed Request for Bid Proposal for:

BID NUMBER: RFB - 2024 - 002
BID TITLE: SUPPLY AND DELIVER STEEL CASTINGS FOR STRUCTURES
BID DUE: MARCH 21, 2024 at 11:00 AM
BID OPENING: MARCH 21, 2024 at 11:00 AM

This sealed bid will be opened and read in the Common Council Chambers and can be viewed on the City of Rome Facebook© Live page.

**March 21, 2024 at 11:00 AM
198 N WASHINGTON ST
ROME, NY 13440**

Proposer's Warranty Form, Responsible Bidder Form and Non-Collusive Statement must be completed and signed and returned with proposal.

Bid must be covered by Money Order, Certified Check, or Bid Bond in the amount of 5% of the amount of the total bid.

Sealed bids must be clearly marked with the bid number and title and sent to the address below, where they will be time-stamped, local time to:

**Office of the City Clerk
Rome City Hall
Suite 1A
198 North Washington Street
Rome, NY 13440**

To view bid docs electronically at www.romenewyork.com; click on Purchasing Department; Bid Opportunities. The City of Rome, New York, reserves the right to reject any or all proposals or to accept any bid deemed to be in its best interest.



GENERAL CONDITIONS

A. SCOPE OF WORK:

- Work shall include the supply and delivery of Steel Castings for Structures as well as other miscellaneous construction materials used by the City of Rome Dept of Public Works.

B. QUESTIONS REGARDING SPECIFICATIONS:

Questions must be directed to:

Patrick D. Surace, PE

PSurace@romecitygov.com

(315) 335-2653

C. CONTRACT PERIOD:

Effective from date of execution to [December 31, 2025](#).

D. TAX:

Purchases by the City of Rome, New York, are not subject to any sales tax, federal excise tax or transportation tax.

E. FINANCE CHARGES:

The City of Rome will not be subjected to finance or late charges under this contract.

F. PRICE AND PRICE ADJUSTMENTS:

Unless otherwise stated in this document, at no time during the term of any contract arising from an award by the City of Rome may any of the contract pricing be changed for any reason without written approval by the City. All pricing shall remain firm for the first six months from the date of award. Once, per each twelve-month period the vendor or the City may request a price adjustment. The vendor shall give the City a minimum of thirty (30) calendar days notification of any request for a price adjustment. Said adjustment may at no time exceed the Consumer Price Index for all items as calculated by the City of Rome Purchasing Department. Should the City deem the requested adjustment unacceptable, the City reserves the right to terminate the contract in accordance with the terms of the bid and seek pricing from whatever sources legally available.

G. DURATION OF PROPOSAL OFFER:

Proposals are irrevocable for a period of forty five (45) calendar days following the closing date of this bid proposal.

H. METHOD OF AWARD:

The contract shall be awarded to the lowest responsible and responsive bidder whose proposal meets the requirements set forth herein. Final determination will be made by the City as deemed to be in its best interests. Taken into consideration will be the reliability of the bidder, the quality of the materials/services offered, their level of quality and conformity with the specifications, and the terms of delivery.

I. ACCEPTANCE OR REJECTION:

The City of Rome Board of Estimate and Contract reserves the right to accept or reject any or all bids received.

J. COMPLETION DATE & DELIVERY SCHEDULE:

Each bidder must include in the proposal an approximate delivery date from contract award. Delivery time may or may not be considered at the time of bid consideration.

K. TIME IS OF THE ESSENCE: All times stated herein are of the essence.

L. NOTICE OF DELAY:

If the successful bidder encounters difficulty in meeting performance requirements or has knowledge of a possible delay, the vendor shall immediately notify the Purchasing Agent, preferably in writing. A slippage will require the vendor to demonstrate an alternate means of recovering the anticipated or actual delay in contract performance.

M. GUARANTEE/WARRANTY

The bidder must guarantee that the equipment offered is a model of regular stock product, with parts regularly used for this type of equipment offered; also, that no attachment or part has been substituted or applied contrary to manufacturer's recommendations or standard practices. The unit delivered must be warranted against faulty materials and workmanship for a period that should such faults develop, the bidder agrees to replace/repair the unit or part affected without cost to the City of Rome, New York, with all replacement parts paid for by the contractor.

N. INSURANCE

The City of Rome New York requires general liability coverage in the amount of \$1,000,000 each occurrence /\$2,000,000 general aggregate, with The City of Rome, New York as certificate holder and additional insured. The accepted form of proof is ACORD 25 (2009/09) – Certificate of Liability Insurance.

For workers' Compensation and Disability Benefits insurance, please use forms C-105.2, U-26.3 or DB120.1, respectively. Information on these forms are located at website (<http://www.wcb.state.ny.us/content/main/Forms.jsp>).

Forms must be signed by an authorized representative of the insurer. All policies must provide for written notice to the City of Rome to be delivered in accordance with the policy provisions. All forms may be completed by your agent/broker, do not require notarization and will be accepted electronically when sent directly from your agent/broker.

<p>C-105.2 (9/07)</p>	<p>Certificate of NYS Workers' Compensation Insurance Coverage (All private NYS licensed workers' compensation carriers are required to issue the C-105.2. Please note that the State Insurance Fund issues a different form, the U-26.3 form, as its version of the C-105.2)</p>	<p>Employers insured for workers' compensation through a private insurance carrier</p>	<p>Filed with any entity requesting to be a certificate holder including a government agency issuing a permit, license or contract. The C-105.2 must be completed by the insurance carrier or its licensed insurance agent.</p>	<p><u>Employers must obtain this form from either their NYS workers' compensation insurance carrier or a licensed NYS insurance agent of that carrier.</u></p> <p>Carriers, their licensed agents, and Self-Insured Employers may email the Board at Certificates@wcb.ny.gov to obtain controlled forms not available on this website.</p>
<p>DB-120.1 (5/06)</p>	<p>Certificate of Insurance Coverage Under the NYS Disability Benefits Law</p>	<p>Employers insured for NYS statutory disability benefits insurance through an insurance carrier.</p>	<p>Filed with any entity requesting to be a certificate holder including a government agency issuing a permit, license or contract. The DB-120.1 must be completed by either the NYS statutory disability benefits insurance carrier, or a licensed NYS insurance agent of that carrier.</p>	<p><u>Employers must obtain this form from either their NYS statutory disability benefits insurance carrier or a licensed NYS insurance agent of that carrier.</u></p> <p>Carriers, their licensed agents, and Self-Insured Employers may email the Board at Certificates@wcb.ny.gov to obtain controlled forms not available on this website.</p>
<p>CE-200 (12/08)</p> <p>(Replaces WC/DB-100 and Form C-105.21)</p>	<p>Certificate of Attestation of Exemption from NYS Workers' Compensation and/or Disability Benefits Coverage</p>	<p>Applicants for permits, licenses or contracts from State, county or municipal agencies in New York State that are not required to carry NYS workers' compensation and/or disability benefits insurance coverage.</p>	<p>Please file with the government agency that is issuing the permit, license or contract. (Examples: The New York City Department of Buildings or the New York State Department of Health)</p>	<p>These exemption forms can <u>ONLY</u> be used to attest to a government entity that an applicant requesting a permit, license or contract from that <u>government</u> entity is not required to carry NYS workers' compensation and/or disability benefits insurance. (Instructions)</p>

O. MINORITY BUSINESS ENTERPRISE PARTICIPATION:

1. Minority and women-owned business enterprises are encouraged in the performance of all City material, supply, professional and construction contracts and sub-contracts;
2. A "minority business enterprise" is defined as a business firm which is at least fifty-one percent (51%) owned by minority group members. The minority ownership must exercise actual day-to-day management and control of the business.
3. "Minority" means Blacks, Hispanics, American Indians, Alaskan Natives, Asians and Pacific Islanders.
4. A "women-owned business enterprise" is defined as a business firm which is at least fifty-one percent (51%) owned by women. The women ownership must exercise actual day-to-day management and control of business.
5. Bidders are requested to provide the following:
 - a. Is your company 51% or more women owned?
 yes no
 - b. Is your company 51% or more minority owned?
 yes no
 - c. If you answer YES to Letter B, check one of the following:
 Black Hispanic Alaskan Native
 Asian/Pacific Islands American Indian

P. CONTRACT TERMINATION:

The City may terminate for cause if the vendor fails to perform any material condition of the contract and such failure continues unresolved for thirty (30) days after receipt of notice from the City.

Q. LIMITATIONS:

1. Neither the vendor nor its affiliates shall be liable in any way for delay, failure in performance, loss damage due to any of the following conditions: fire, explosion, power blackout, earthquake, flood, the elements, civil or military authority, or acts of God.
2. The vendor shall be liable for any delay, loss, and property damage attributable to any service or actions of any of its employees or agents.

R. GENERAL:

1. Any modification or waiver of any provision of the Contract must be in writing and signed by authorized representatives of both parties.
2. If any term or provision of the contract shall be held invalid or unenforceable, the remainder of the contract shall not be affected.
3. The waiver by either party of any breach of the Contract by the other party will not operate as a waiver of subsequent breaches of the same or different kind.

S. DEVIATIONS FROM SPECIFICATIONS: (not applicable)

T. LITERATURE:

Each bidder shall include product or equipment literature as available.

U. PROTEST AND APPEAL PROCEDURES:

1. Protests regarding the validity or appropriateness of the specifications or of the Request for proposal shall be filed in writing with the City Clerk no later than two (2) days prior to the closing of the bids. The address to submit the protest is:
City Clerk
City of Rome
198 N. Washington St.
Rome, New York 13440
2. Such protests will not be considered if received later than the date established in paragraph above.
3. Protests shall be explicit and in sufficient detail to stand on their own record.
4. Post-award protests shall be in writing in a diligent and timely fashion and to be received in the City Clerk's Office no later than five (5) days after receipt of the award notice.



STATE OF NEW YORK, Section 103-a

GENERAL MUNICIPAL LAW COMPLIANCE

"Upon the refusal of a person, when called before a Grand Jury to testify concerning any transaction or contract had with the State, any political subdivision thereof, a public authority or with any public department, agency or an official of the state or any political subdivision thereof or of a public authority, to sign a waiver of immunity against subsequent criminal prosecution or to answer any relevant questions concerning such transaction or contract, (a) such person, and any firm, partnership or corporation of which he is a member, partner, or director or officer shall be disqualified from thereafter selling to or submitting bids to or receiving awards from or entering into any contracts with any municipal corporation or any public department, agency or official thereof for goods, work or services, for a period of five years after such refusal, and (b) any and all contract made with any municipal corporation or any public department, agency or official thereof, since the effective date of this law, by such person, and by any firm, partnership or corporation of which he is a member, partner, director or officer may be cancelled or terminated by the municipal corporation without incurring any penalty or damages on account of such cancellations or termination, by any monies owing by the municipal corporation for goods delivered or work done prior to the cancellation or termination shall be paid all pursuant to Section 103-a of the General Municipal Law of the State of New York."

Effective: July 1, 1959



ATTENTION

This bid may not be acceptable without completing the following information. For your protection, please review your bid and indicate by a check mark that all requested information has been included.

1. () BID BOND OR CERTIFIED CHECK
2. () BID SPECIFICATIONS
3. () BIDDERS MANUFACTURING SPECIFICATIONS IF APPLICABLE
4. () BIDDERS REFERENCES
5. () BIDDERS QUALIFICATIONS
6. () MANUFACTURERS WARRANTIES
7. () INSTRUCTIONS TO BIDDERS
8. () RESPONSIBLE BIDDER FORM
9. () PROPOSER'S WARRANTY (On Page 1)
10. () NON-COLLUSIVE STATEMENT
11. () DELIVERY DATE

Do not separate or remove any pages from this bid package. Doing so may render your bid invalid. Please return the checklist with your bid.



RESPONSIBLE BIDDER

Each bidder will complete the following to enable the City to determine a Responsible Bidder.

- A. Is your firm presently engaged in actions which will lead to a merger, consolidation, or other form of reorganization?

_____ yes x no

- B. Has your firm filed for bankruptcy? _____ yes x no

In determining the "lowest responsible bidder," in addition to price, the purchasing authority shall consider the ability, capacity and skill of the bidder to perform the contract or provide the service required; whether the bidder can perform the contract or provide the service promptly or within the time specified, without delay or interference; the character, integrity, reputation, judgment, experience and efficiency of the bidder; the quality of performance or previous contracts or services; the and existing compliance by the bidder with laws and ordinances relating to the contract or service; the sufficiency of the financial resources and ability of the bidder to perform the contract or provide the service; the quality, availability and adaptability of the supplies or contractual services to the particular use required; the ability of the bidder to provide future maintenance and service for the use of the subject of the contract; and the number and scope of conditions attached to the bid.



NON-COLLUSIVE BIDDING CERTIFICATE

Pursuant to Chapter 675, Laws of 1966

(a) By submission of this bid, each bidder and each person signing on behalf of any bidder certifies, and in the case of a joint bid, each party thereto certifies as to its own organization, under penalty of perjury, that to the best of knowledge and belief:

- (1) The prices in this bid have been arrived at independently without collusion, consultation, communication, or agreement, for the purpose of restricting competition, as to any matter relating to such process with any other bidder or with any competitor:
- (2) Unless otherwise required by law, the prices which have been quoted in this bid have not been knowingly disclosed by the bidder and will not knowingly disclosed by the bidder prior to opening, directly or indirectly, to any other bidder or to any competitor; and
- (3) No attempt has been made or will be made by the bidder to induce any other person, partnership or corporation to submit or not submit a bid for the purposes of restricting competition.

EJ USA, Inc.

(Name of Bidder)



(Official capacity)

Richard Brandell, Vice President & General Manager



TECHNICAL SPECIFICATIONS

Supply and Deliver Steel Castings for Structures

- Delivery of materials will be made to:

City of Rome Dept of Public Works
132 Race Street
Rome, NY 13440
- Construction materials will be ordered by the City of Rome from the successful bidder on an as need basis throughout the contract period.
- Quantities of materials ordered will vary throughout the contract period, however at a minimum no separate order will amount to less than \$2,000.00.
- Each bid item pricing will include all costs of delivery.
- Complete material orders must be delivered and received within two weeks of the order date, unless a mutual agreement is arranged between the successful bidder and the City of Rome to allow for an extended delivery date.
- Partial deliveries will only be accepted if an agreement is arranged between the successful bidder and the City of Rome.
- Please include all standard construction material specification sheets listed on the bid itemization list with Bid Package. Specification sheets should include all relevant product information including but not limited to product materials, product numbers, dimensions, and all other pertinent information, etc.
- All bid items listed are manufactured by EJ USA INC. Alternate products may be approved and accepted as an equal substitution by the City of Rome upon review of bid packages received. Review of bid packages and specification sheets submitted will determine the acceptance or denial of an equal product substitution.

RFB 2024-002 Supply and Deliver Steel Castings for Structures

ITEM NO.	DESCRIPTION	QTY	UNIT PRICE	TOTAL AMOUNT
1	EJ USA 32 Inch MH Frame & Cover 1322Z Frame – 1480C Cover Products #00132213 & #00148089	6 EA	\$698.15	\$4,188.90
2	EJ USA 25 In Sq CB Frame & Grate 7295Z Frame – 7295M Grate Products #00729510 & #00729530	140 EA	\$607.46	\$85,044.40
3	EJ USA 25 In MH Frame & Cover Self Level Frame – 1203C Cover Products #00302433 & #00120423	10 EA	\$1,054.15	\$10,541.50
4	EJ USA Curb DI CB Frame & Grate 7010Z Frame – 7010M1 Grate Products #00701010 & #00701030	12 EA	\$690.88	\$8,290.56
5	EJ USA 24 Inch MH Frame & Cover 1310Z Frame – 11310C2 Cover Products #00131011 & #001310007	125 EA	\$330.37	\$41,296.25
6	EJ USA 1.5 Inch Riser 24 Inch Opening M5 Adjustable Steel Riser Product #M5 Riser	20 EA	\$258.68	\$5,173.60
7	EJ USA ADA Detectable Warning Plate 7007 Duralast Detectable 30 In x 24 In Product #00700721	80 EA	\$125.73	\$10,058.40
8	EJ USA 24 In Round CB Frame & Grate 1312Z Frame – 1310 Grate Products #00131211 & #00131034	20 EA	\$311.14	\$6,222.80
9	EJ USA 12 Inch Valve Box - Top Section 8550 Valve Box Top – 12T Product #85507012	24 EA	\$58.55	\$1,405.20
10	EJ USA 16 Inch Valve Box - Top Section 8550 Valve Box Top – 16T Product #85507016	36 EA	\$82.50	\$2,970.00
11	EJ USA 26 Inch Valve Box - Top Section 8550 Valve Box Top – 26T Product #85507026	36 EA	\$104.95	\$3,778.20
12	EJ USA 24 Inch Valve Box - Bottom 8560 Valve Box Bottom – 24B Product #85606024	24 EA	\$84.79	\$2,034.96
13	EJ USA 12 Inch Valve Box - Base 8560 #6 Valve Box Base Product #85605006	24 EA	\$85.94	\$2,062.56
14	EJ USA 6 Inch Valve Box Cover 6800 Valve Box Cover Product #06800001	72 EA	\$26.52	\$1,909.44
	TOTAL BID AMOUNT IN FIGURES:		\$184,976.77	
	COMPANY NAME:	EJ USA, Inc.		



Current Contracts

City of Chicago

Agency/Owner: City of Chicago
Contract Number: 124843
Goods Provided: Manhole/Catch Basin Frames, Lids
Name & Location: City of Chicago, IL
Start/Completion: 6/1/2015 - 11/29/2023
Contract Amount: \$6,571,177
Contact: Aileen Velazquez, Chief Procurement Officer, 312-744-9750

Delaware Department of Transportation

Agency/Owner: Delaware Department of Transportation
Contract Number: DOT1909
Goods Provided: Catch Basin Components
Name & Location: Delaware DOT, Dover, DE
Start/Completion: 7/19/2019 - 1/31/2022
Contract Amount: \$253,882
Contact: Buffy Gerald, Administrative Specialist, 302-760-2410

City of Naperville

Agency/Owner: City of Naperville
Contract Number: 18-052
Goods Provided: Manhole Frames & Grates
Name & Location: City of Naperville, IL
Start/Completion: 8/7/2018 - 12/31/2022
Contract Amount: \$118,257
Contact: Bryn Wildman, Procurement Officer, 630-420-6720

City of Framingham

Agency/Owner: City of Framingham
Contract Number: PW-437
Goods Provided: Manhole and Catch Basin Frames & Covers
Name & Location: City of Framingham, MA
Start/Completion: 7/15/2020 - 7/15/2023
Contract Amount: \$113,149
Contact: Ann O'Regan, Capital Procurement Administrator, 508-532-6040

Monroe County

Agency/Owner: Monroe County
Contract Number: 4700007549
Goods Provided: Construction Castings
Name & Location: Monroe County, NY
Start/Completion: 11/13/2019 - 9/30/2023
Contract Amount: \$258,181
Contact: Sean Wilcox, Buyer, 585-753-1136



CERTIFICATE OF LIABILITY INSURANCE

DATE (MM/DD/YYYY)
03/01/2024

THIS CERTIFICATE IS ISSUED AS A MATTER OF INFORMATION ONLY AND CONFERS NO RIGHTS UPON THE CERTIFICATE HOLDER. THIS CERTIFICATE DOES NOT AFFIRMATIVELY OR NEGATIVELY AMEND, EXTEND OR ALTER THE COVERAGE AFFORDED BY THE POLICIES BELOW. THIS CERTIFICATE OF INSURANCE DOES NOT CONSTITUTE A CONTRACT BETWEEN THE ISSUING INSURER(S), AUTHORIZED REPRESENTATIVE OR PRODUCER, AND THE CERTIFICATE HOLDER.

IMPORTANT: If the certificate holder is an ADDITIONAL INSURED, the policy(ies) must have ADDITIONAL INSURED provisions or be endorsed. If SUBROGATION IS WAIVED, subject to the terms and conditions of the policy, certain policies may require an endorsement. A statement on this certificate does not confer rights to the certificate holder in lieu of such endorsement(s).

PRODUCER MARSH USA LLC. 125 Ottawa Avenue NW Suite 400 Grand Rapids, MI 49503 Attn: grandrapids.certrequest@marsh.com CN107506037-EAST-GAWUP-24-25	CONTACT NAME: PHONE (A/C, No, Ext): FAX (A/C, No): E-MAIL ADDRESS:														
	<table border="1"> <thead> <tr> <th>INSURER(S) AFFORDING COVERAGE</th> <th>NAIC #</th> </tr> </thead> <tbody> <tr> <td>INSURER A : National Union Fire Insurance Co. of Pittsburgh, PA</td> <td>19445</td> </tr> <tr> <td>INSURER B : New Hampshire Insurance Company</td> <td>23841</td> </tr> <tr> <td>INSURER C : Safety National Casualty Corporation</td> <td>15105</td> </tr> <tr> <td>INSURER D : N/A</td> <td>N/A</td> </tr> <tr> <td>INSURER E : N/A</td> <td>N/A</td> </tr> <tr> <td>INSURER F :</td> <td></td> </tr> </tbody> </table>		INSURER(S) AFFORDING COVERAGE	NAIC #	INSURER A : National Union Fire Insurance Co. of Pittsburgh, PA	19445	INSURER B : New Hampshire Insurance Company	23841	INSURER C : Safety National Casualty Corporation	15105	INSURER D : N/A	N/A	INSURER E : N/A	N/A	INSURER F :
INSURER(S) AFFORDING COVERAGE	NAIC #														
INSURER A : National Union Fire Insurance Co. of Pittsburgh, PA	19445														
INSURER B : New Hampshire Insurance Company	23841														
INSURER C : Safety National Casualty Corporation	15105														
INSURER D : N/A	N/A														
INSURER E : N/A	N/A														
INSURER F :															
INSURED EJ USA, Inc. Attn: Tina Anderson PO Box 439 301 Spring Street East Jordan, MI 49727															

COVERAGES **CERTIFICATE NUMBER:** CHI-007135355-24 **REVISION NUMBER:** 4

THIS IS TO CERTIFY THAT THE POLICIES OF INSURANCE LISTED BELOW HAVE BEEN ISSUED TO THE INSURED NAMED ABOVE FOR THE POLICY PERIOD INDICATED. NOTWITHSTANDING ANY REQUIREMENT, TERM OR CONDITION OF ANY CONTRACT OR OTHER DOCUMENT WITH RESPECT TO WHICH THIS CERTIFICATE MAY BE ISSUED OR MAY PERTAIN, THE INSURANCE AFFORDED BY THE POLICIES DESCRIBED HEREIN IS SUBJECT TO ALL THE TERMS, EXCLUSIONS AND CONDITIONS OF SUCH POLICIES. LIMITS SHOWN MAY HAVE BEEN REDUCED BY PAID CLAIMS.

INSR LTR	TYPE OF INSURANCE	ADDL INSD	SUBR WVD	POLICY NUMBER	POLICY EFF (MM/DD/YYYY)	POLICY EXP (MM/DD/YYYY)	LIMITS
A	<input checked="" type="checkbox"/> COMMERCIAL GENERAL LIABILITY <input type="checkbox"/> CLAIMS-MADE <input checked="" type="checkbox"/> OCCUR GEN'L AGGREGATE LIMIT APPLIES PER: <input checked="" type="checkbox"/> POLICY <input type="checkbox"/> PRO-JECT <input type="checkbox"/> LOC OTHER:			GL 5180142	03/01/2024	03/01/2025	EACH OCCURRENCE \$ 2,000,000 DAMAGE TO RENTED PREMISES (Ea occurrence) \$ 100,000 MED EXP (Any one person) \$ 25,000 PERSONAL & ADV INJURY \$ 2,000,000 GENERAL AGGREGATE \$ 4,000,000 PRODUCTS - COMP/OP AGG \$ 4,000,000 \$
	AUTOMOBILE LIABILITY <input type="checkbox"/> ANY AUTO <input type="checkbox"/> OWNED AUTOS ONLY <input type="checkbox"/> SCHEDULED AUTOS <input type="checkbox"/> HIRED AUTOS ONLY <input type="checkbox"/> NON-OWNED AUTOS ONLY						COMBINED SINGLE LIMIT (Ea accident) \$ BODILY INJURY (Per person) \$ BODILY INJURY (Per accident) \$ PROPERTY DAMAGE (Per accident) \$ \$
	<input type="checkbox"/> UMBRELLA LIAB <input type="checkbox"/> OCCUR <input type="checkbox"/> EXCESS LIAB <input type="checkbox"/> CLAIMS-MADE DED RETENTION \$						EACH OCCURRENCE \$ AGGREGATE \$ \$
B	WORKERS COMPENSATION AND EMPLOYERS' LIABILITY <input type="checkbox"/> Y / <input checked="" type="checkbox"/> N ANY PROPRIETOR/PARTNER/EXECUTIVE OFFICER/MEMBER EXCLUDED? (Mandatory in NH) If yes, describe under DESCRIPTION OF OPERATIONS below			WC 12016145 (AOS)	03/01/2024	03/01/2025	<input checked="" type="checkbox"/> PER STATUTE <input type="checkbox"/> OTH-ER
A				WC 080756335 (CA)	03/01/2024	03/01/2025	E. L. EACH ACCIDENT \$ 1,000,000
C				SP 4066302	03/01/2024	03/01/2025	E. L. DISEASE - EA EMPLOYEE \$ 1,000,000
				(Subject to SIR per terms & cond's)			E. L. DISEASE - POLICY LIMIT \$ 1,000,000

DESCRIPTION OF OPERATIONS / LOCATIONS / VEHICLES (ACORD 101, Additional Remarks Schedule, may be attached if more space is required)
THE CITY OF ROME, NEW YORK IS/ARE INCLUDED AS ADDITIONAL INSURED WHERE REQUIRED BY WRITTEN CONTRACT WITH RESPECT TO GENERAL LIABILITY.

CERTIFICATE HOLDER

THE CITY OF ROME, NEW YORK
ATTN: DONNA PIEKARSKI, PURCHASING AGENT
198 NORTH WASHINGTON STREET
ROME, NY 13440

CANCELLATION

SHOULD ANY OF THE ABOVE DESCRIBED POLICIES BE CANCELLED BEFORE THE EXPIRATION DATE THEREOF, NOTICE WILL BE DELIVERED IN ACCORDANCE WITH THE POLICY PROVISIONS.

AUTHORIZED REPRESENTATIVE

Marsh USA Inc.

© 1988-2016 ACORD CORPORATION. All rights reserved.



EJ
301 Spring Street
PO Box 439
East Jordan, MI 49727-0439

+1 231 536 2261
800 574 4100
ejco.com

January 26, 2024

Dear Valued Customer

SUBJECT: Warranty: Construction Castings

Customer Terms and Conditions of Sale for EJ USA, Inc., can be viewed on our website at r.ejco.com/ustc and contains our general warranty information.

Section 6 of our Customer Terms and Conditions contains warranty information for our products:

Warranties and Limited Remedies. Unless otherwise set forth in the quotation, Seller warrants to Buyer only that, at the time of delivery, the goods will be free from defects in material and workmanship and will conform to any mutually agreed upon written specifications and/or drawings. If, however, Buyer's representative agrees, either orally or in writing, to a change in or waiver of a portion of the specifications for any shipment of goods, then such goods shall be considered conforming if they conform to the specifications as changed or with such waived portion excluded. The warranty period for the goods shall be as follows:

- a. For hydrants, valves, or detectable warning plates manufactured by Seller, the warranty period shall be ten years from the date of delivery.
- b. For aluminum hatches manufactured by Seller, the warranty period shall be five years from the date of delivery.
- c. For all other goods manufactured by Seller, the warranty period shall be one year from the date of delivery.

Buyer agrees to inspect all of the goods immediately upon receipt from Seller. In the event that Buyer believes that a good is non-conforming with the warranties specified herein, then Buyer will promptly notify Seller of the alleged defect in writing and provide to Seller as much information as is available to Buyer about the alleged non-conformity. If requested by Seller, Buyer will return to Seller all (or, if not feasible, a statistically significant sample) of the allegedly non-conforming goods and the assemblies into which such goods are incorporated, if applicable, together with any additional information or documentation reasonably requested by Seller, for the purpose of determining if the goods are non-conforming with the warranties specified herein.

If Seller determines that the goods are non-conforming, Seller's sole liability to Buyer and Buyer's SOLE AND EXCLUSIVE REMEDY under this warranty (whether or not the non-conforming goods have been installed and must be the subject of a recall, customer satisfaction or other service campaign or similar action) is limited to the repair or replacement of the non-conforming goods only; provided, however, that written notice that the goods are potentially non-conforming must be given by Buyer to Seller within five (5) days after the delivery of the goods to Buyer or, if Buyer's inspection of the goods could not have uncovered the potential non-conformance, within thirty (30) days after Buyer knew or reasonably should have known that the goods were potentially non-conforming, including, but not limited to, through information received from Buyer's direct or indirect customer or any other third party. For clarity, Seller shall not be responsible for the expense of locating or removing the non-conforming goods or re-installing any repaired or replacement goods. Except as stated herein, Buyer shall not have any right of rejection or revocation of acceptance of goods.

SPECIFICALLY EXCLUDED FROM THIS PARAGRAPH AND ANY WARRANTY ARE THE FOLLOWING, FOR WHICH SELLER SHALL HAVE NO LIABILITY WHATSOEVER: (i) Design defects in the goods, to the extent that the goods are designed, in whole or in part, by Buyer or a third party; (ii) defects or damage caused by unauthorized or improper installation, alteration, repair, maintenance (including failure to provide appropriate maintenance), storage, handling or operation of the goods by Buyer or any third party; (iii) goods considered by Seller to be

samples, prototype, development or pre-production, which are provided on an "AS IS" basis only; (iv) goods sold by Seller but manufactured by a different entity, which are sold by Seller on an "AS IS" basis, provided, however, that Seller assigns to Buyer any warranties provided by the manufacturers of such goods, to the extent that they are assignable; (v) any product, system, or assembly not manufactured or sold by Seller and/or the integration, incorporation, interaction, connection, placement, or use of the goods in or with any such product, system, or assembly, (vi) goods that have been subject to damage attributable to or caused by: (a) misuse, abuse, or vandalism or any transit related damage; (b) acts of God or insurrection; (c) normal wear and tear; (d) or any other acts that are beyond Seller's reasonable control.

THE FOREGOING WARRANTIES ARE EXCLUSIVE AND ARE GIVEN AND ACCEPTED IN LIEU OF ANY AND ALL OTHER WARRANTIES, EXPRESS OR IMPLIED, INCLUDING, WITHOUT LIMITATION, THE IMPLIED WARRANTIES OF MERCHANTABILITY, FITNESS FOR A PARTICULAR PURPOSE, AND AGAINST INFRINGEMENT, AND BUYER IS SOLELY RESPONSIBLE FOR THE SELECTION OF THE GOODS AND DETERMINING THE PROPER APPLICATION AND USE OF THE GOODS. THE REMEDIES OF THE PURCHASER SHALL BE LIMITED TO THOSE PROVIDED HEREIN TO THE EXCLUSION OF ANY AND ALL OTHER REMEDIES. NO AGREEMENT VARYING OR EXTENDING THE FOREGOING WARRANTIES, REMEDIES, OR THIS LIMITATION WILL BE BINDING UPON SELLER UNLESS IN WRITING AND SIGNED BY A DULY AUTHORIZED OFFICER OF SELLER.

Sincerely,

EJ USA, Inc.

A handwritten signature in blue ink, appearing to read "Richard Brandell".

Richard Brandell
Vice President and General Manager

1322Z Frame

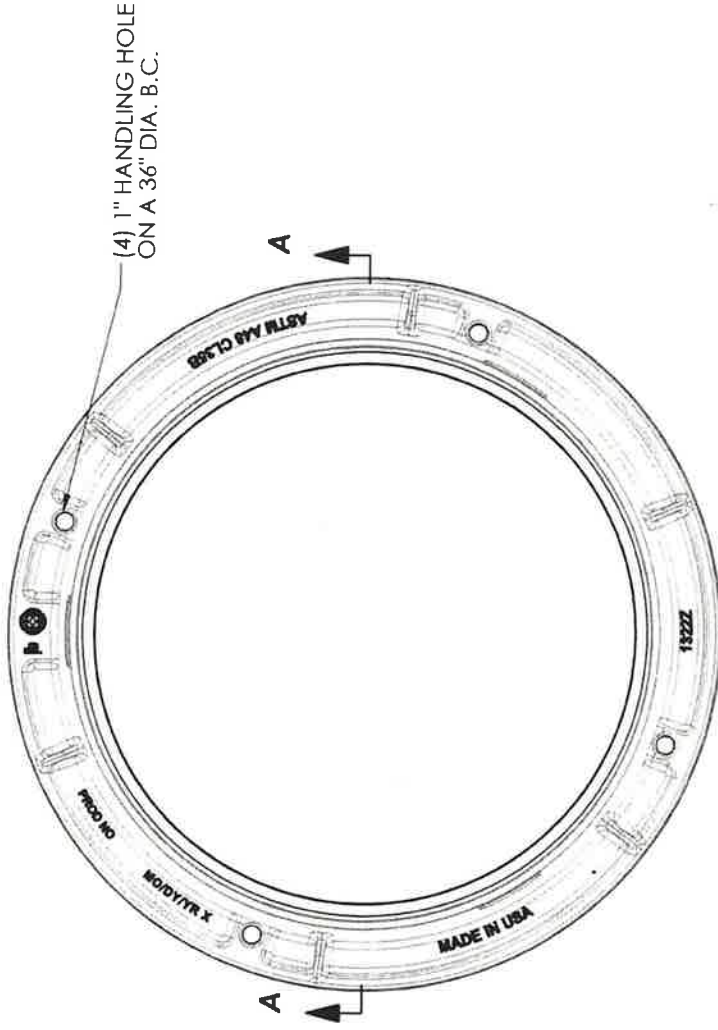

(4) 1" HANDLING HOLE
ON A 36" DIA. B.C.

Product Number

00132213

Design Features

- Materials
Gray Iron (CL35B)
- Design Load
Heavy Duty
- Open Area
n/a
- Coating
Undipped
- Designates Machined Surface
- Estimated Weight: 143 lbs.

Certification

- ASTM A48
- AASHTO M306
- H25
- Country of Origin: USA

Drawing Revision

1/21/2011 Designer: JJJ
3/2/2017 Revised By: MAH

Disclaimer

Models, dimensions, materials, and drawings provided for your reference. We reserve the right to modify specifications without prior notice.
CONFIDENTIAL: This drawing is the property of EJC Group, Inc. and embodies confidential information, registered marks, patents, trade secret information and/or know-how that is the property of EJC Group, Inc. Copyright © 2012 EJC Group, Inc. All rights reserved.

Contact

800 626 4653
ejco.com



SECTION A-A

1480C Cover

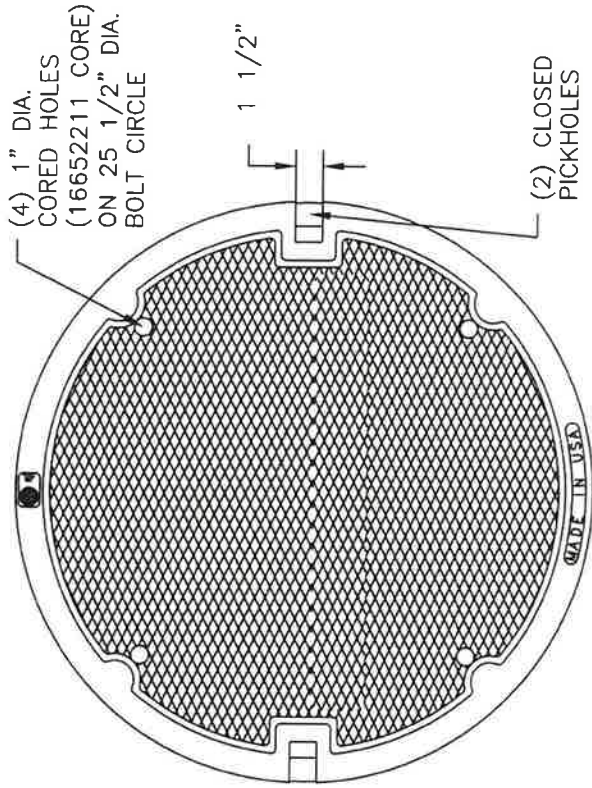

PLAN VIEW

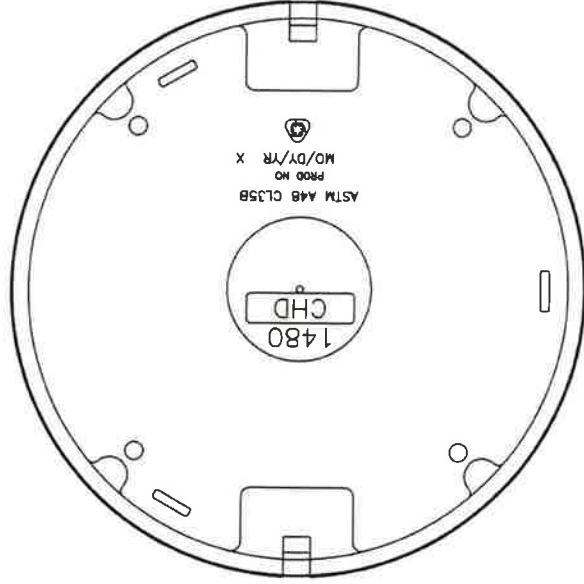

BOTTOM VIEW

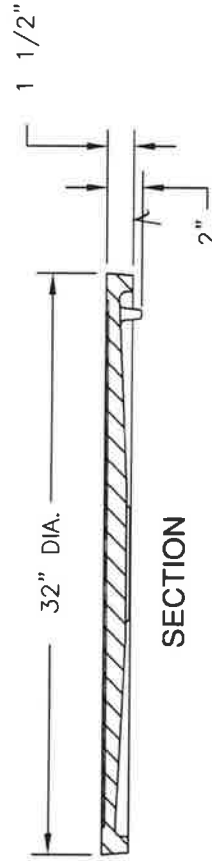

SECTION

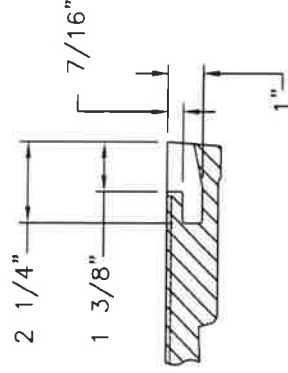

PICKHOLE DETAIL

Product Number

00148089

Design Features

- Materials
Gray Iron (CL35B)
- Design Load
Heavy Duty
- Open Area
n/a
- Coating
Dipped
- Designates Machined Surface

Certification

- ASTM A48
- Country of Origin: USA

Drawing Revision

01/15/2004 Designer: TCL
6/24/2014 Revised By: DAE

Disclaimer

Weights (lbs, kg), dimensions (inches/mm) and tolerances are provided for your guidance. We reserve the right to modify specifications without prior notice.

CONFIDENTIAL This drawing is the property of EJ GROUP, Inc., and embodies confidential information, registered marks, patents, trade secret information, and/or know how that is the property of EJ GROUP, Inc. Copyright © 2011 EJ GROUP, Inc. All rights reserved.

Contact

800 626 4653
ejco.com

7295M Grate

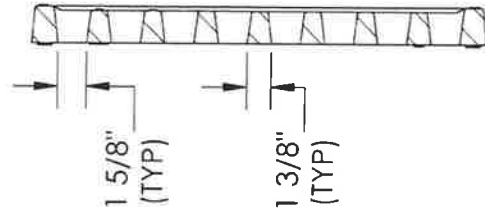
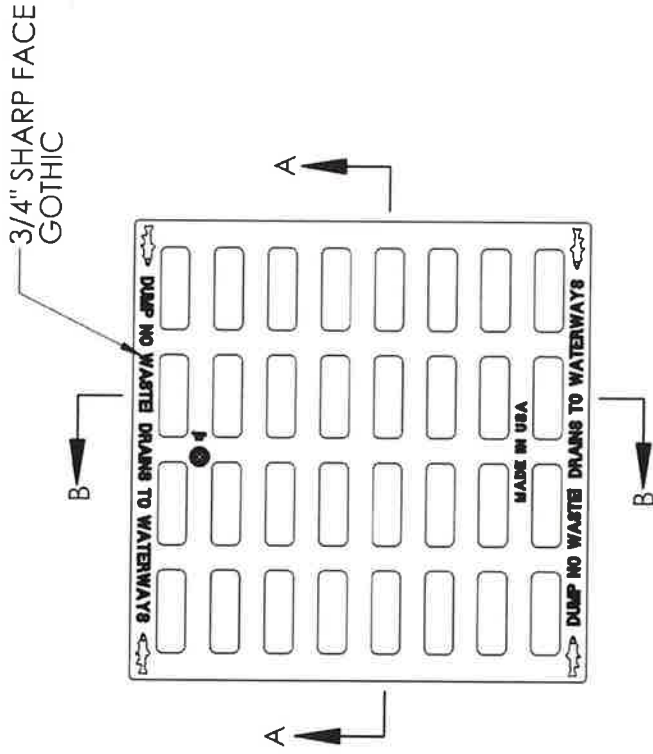

SECTION B-B

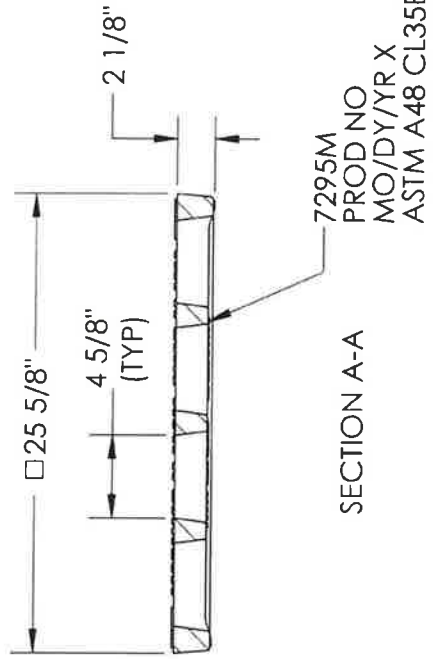

SECTION A-A

Product Number
00729530

Design Features
 -Materials
 Gray Iron (CL35B)
 -Design Load
 Heavy Duty
 -Open Area
 237 Sq. in.
 -Coating
 Undipped
 -√ Designates Machined Surface

Certification
 -ASTM A48
 -AASHTO HS20-44
 -Country of Origin USA

Drawing Revision
 12/20/2016 Designer: DJH
 01/26/2017 Revised By DJH

Disclaimer
 Weights (lbs/kg), dimensions (inches/mm), and drawings provided for your guidance. We reserve the right to modify specifications without prior notice.

CONFIDENTIAL: This drawing is the property of E.J. Group, Inc. and embodies confidential information and/or know-how that is the property of E.J. Group, Inc. Copyright © 2015 E.J. Group, Inc. All rights reserved.

Contact
 800 626 4653
 ejco.com

7295Z Frame

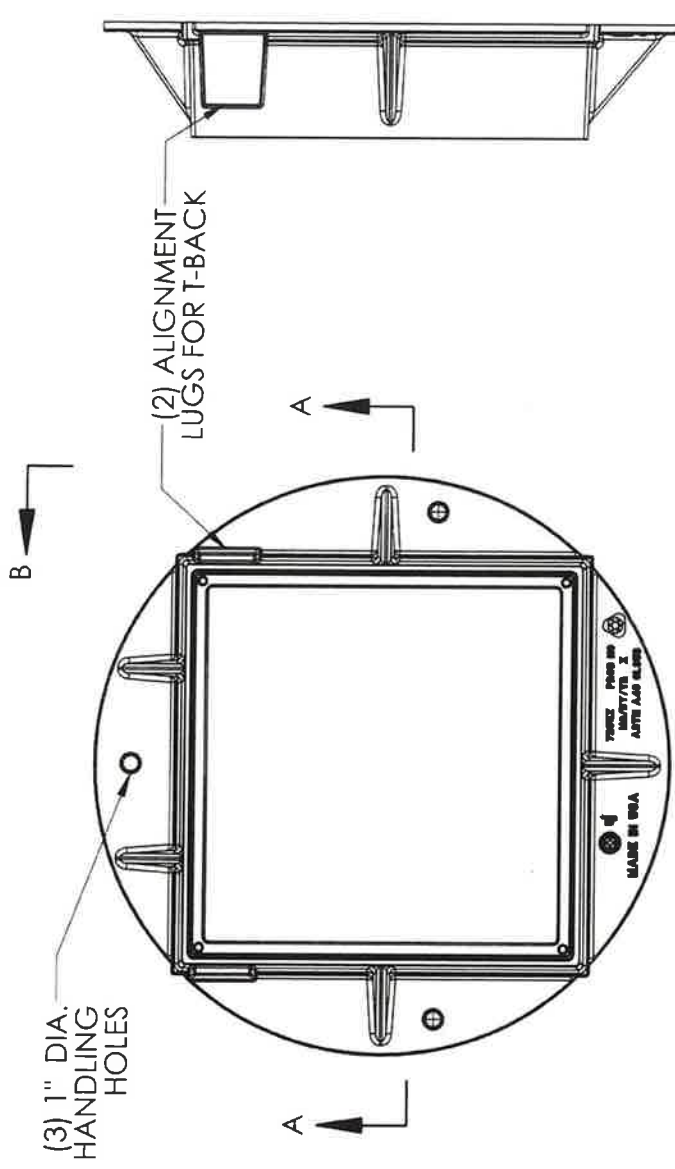

Product Number

00729510

Design Features

- Materials
Gray Iron (CL35B)
- Design Load
Heavy Duty
- Open Area
n/a
- Coating
Unipped
- ∇ Designates Machined Surface

Certification

- ASTM A48
- AASHTO HS20-44
- Country of Origin USA

SECTION B-B

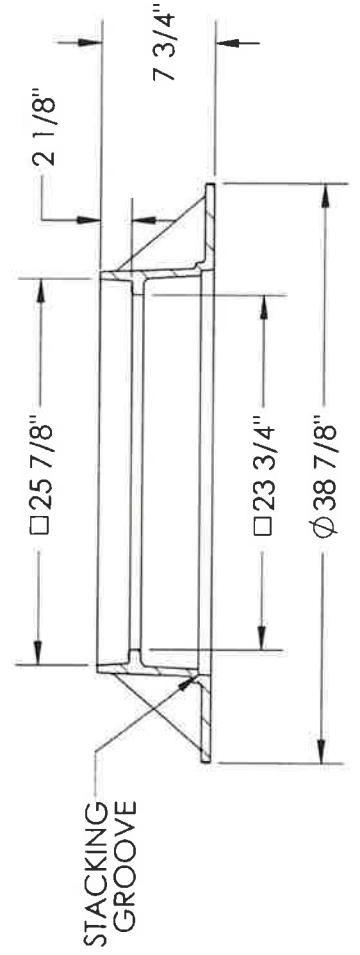

SECTION A-A

Drawing Revision

01/09/2017 Designer: DJH
08/29/2017 Revised By: DJH

Disclaimer

Weights, tolerances, dimensions (inches/mm) and drawings provided for your guidance. We reserve the right to modify specifications without prior notice.
CONFIDENTIAL: This drawing is the property of EJ Group, Inc. and embodies confidential information, registered marks, patents, trade secret information and/or know-how that is the property of EJ Group, Inc. Copyright © 2015 EJ Group, Inc. All rights reserved.

Contact

800.626.4653
ejco.com

SELFLEVEL Assembly

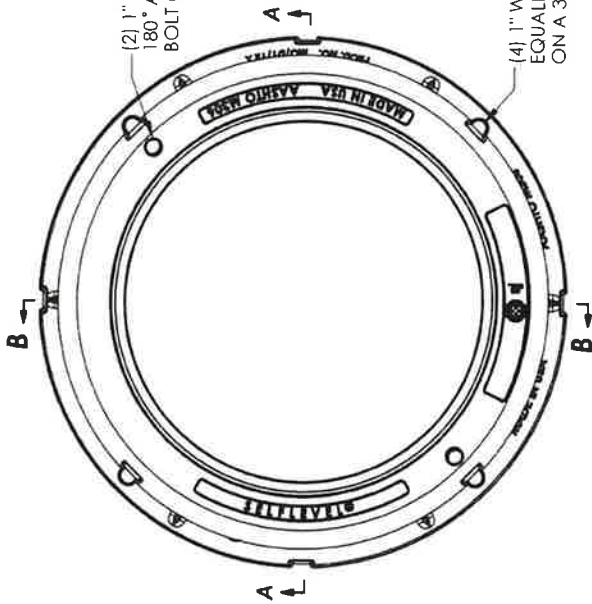

SPECIAL GASKET FOR KEEPING
OUT DEBRIS & STILL ALLOWING
FULL RANGE OF MOTION

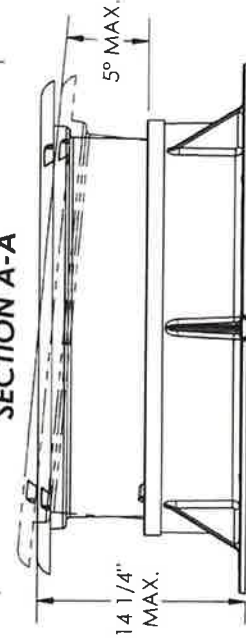
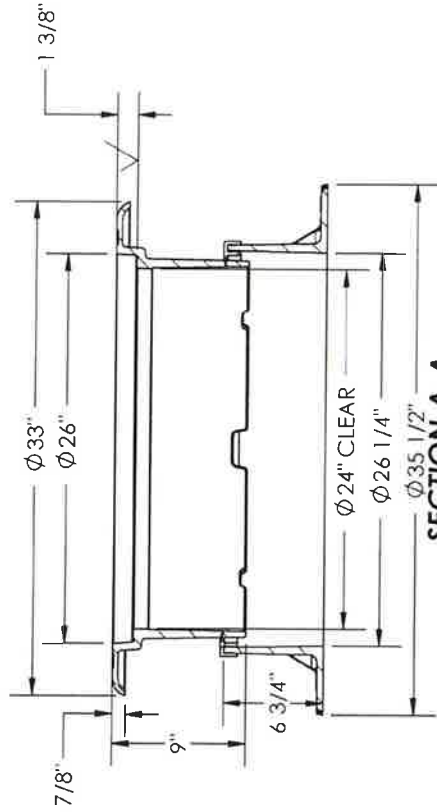
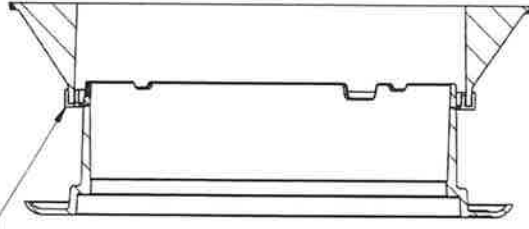

SECTION B-B

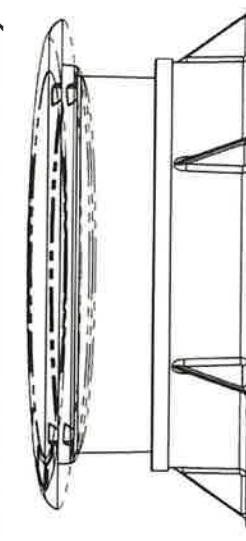
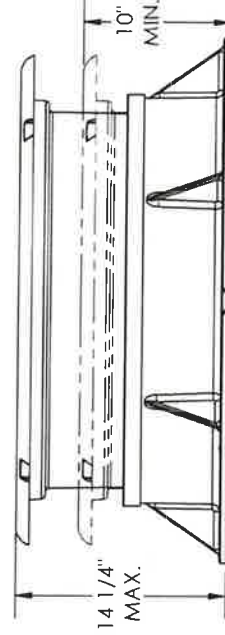

Product Number
00302433

Design Features

- Materials
Frame
Ductile Iron (80-55-06)
Frame
Ductile Iron (80-55-06)

- Design Load
Heavy Duty
- Open Area
n/a
- Coating
Undipped
- Designates Machined Surface

Certification
-ASTM A536

-Country of Origin USA

Major Components
00302412
00302417

Drawing Revision
8/8/2016 Designer: DAE
6/26/2017 Revised By: DAE

Disclaimer

Weights, tolerances, dimensions, finishes, and drawings provided for your guidance. We reserve the right to modify specifications without prior notice.
CONFIDENTIAL: This drawing is the property of EJ Group, Inc. and contains confidential information registered marks, patents, trade secret information and other knowledge that is the property of EJ Group, Inc. Copyright © 2017 EJ Group, Inc. All rights reserved.

Contact
800.626.4653
ejco.com

1203C Cover

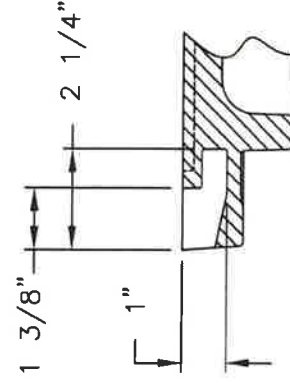
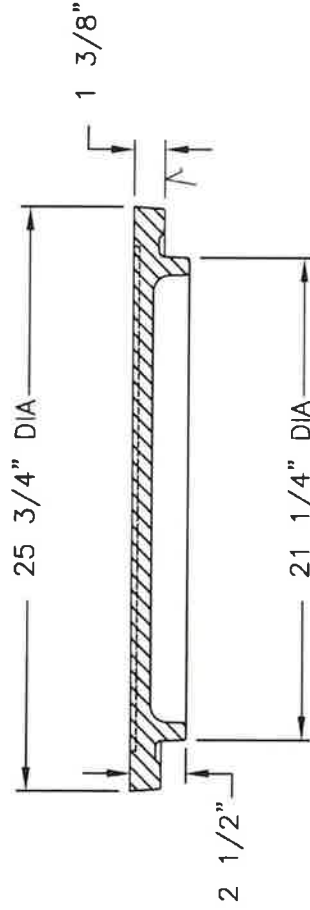
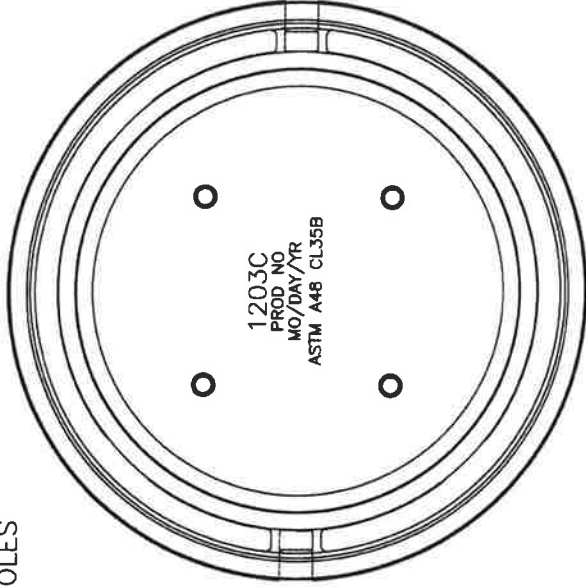
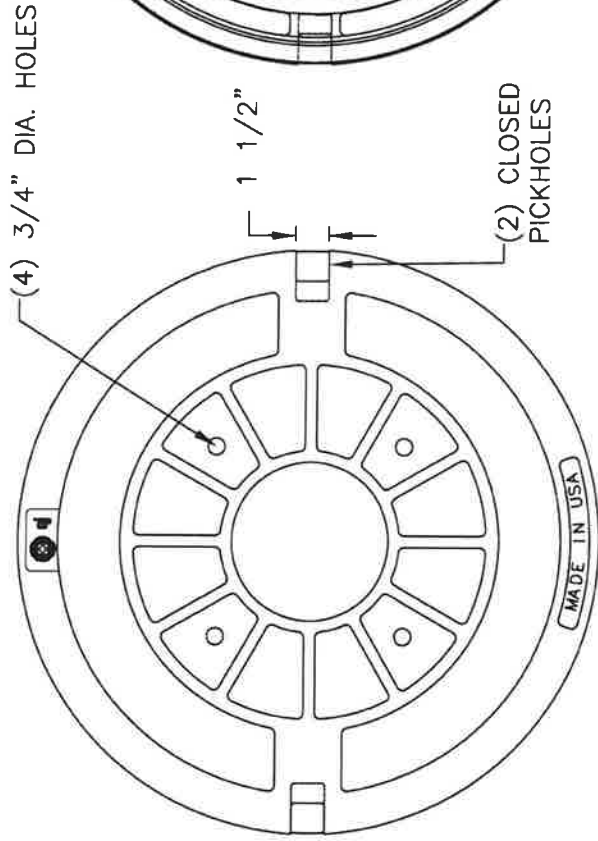

COVER SECTION

Product Number
00120423

Design Features

- Materials
Gray Iron (CL35B)
- Design Load
Heavy Duty
- Open Area
n/a
- Coating
Undipped
- Designates Machined Surface

Certification

- ASTM A48
- Country of Origin: USA

Drawing Revision

05/20/2006 Designer: TCL
12/30/2013 Revised By: DVD

Disclaimer

Weights (lbs./kg) dimensions (inches/mm) and drawings provided for your guidance. We reserve the right to modify specifications without prior notice.

CONFIDENTIAL: This drawing is the property of EJ GROUP, Inc., and embodies confidential information, registered marks, patents, trade secret information, and/or know how that is the property of EJ GROUP, Inc. Copyright © 2012 EJ GROUP, Inc. All rights reserved

Contact

800 626 4653
ejco.com

7010Z Curb Inlet Frame



Product Number

00701010

Design Features

- Materials
Gray Iron (CL35B)
- Design Load
Heavy Duty
- Open Area
n/a
- Coating
Dipped
- Designates Machined Surface

Certification

- ASTM A48
- Country of Origin: USA

Weight:

- 151 lbs

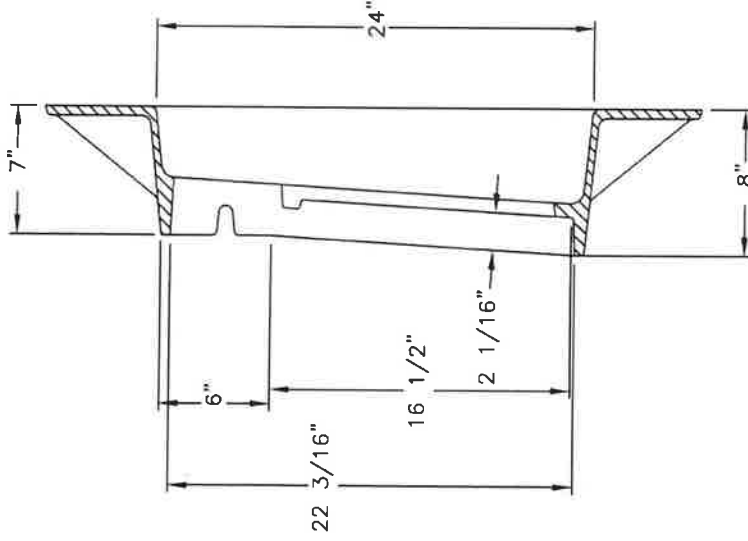

SECTION

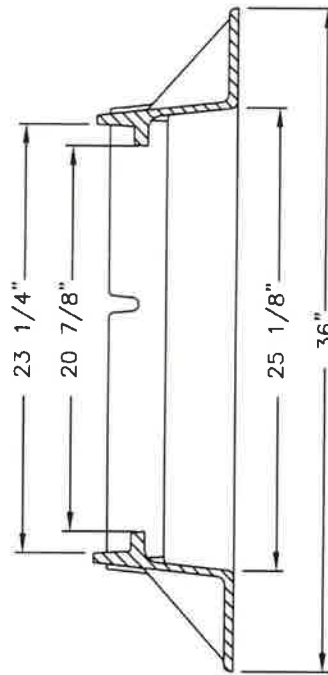
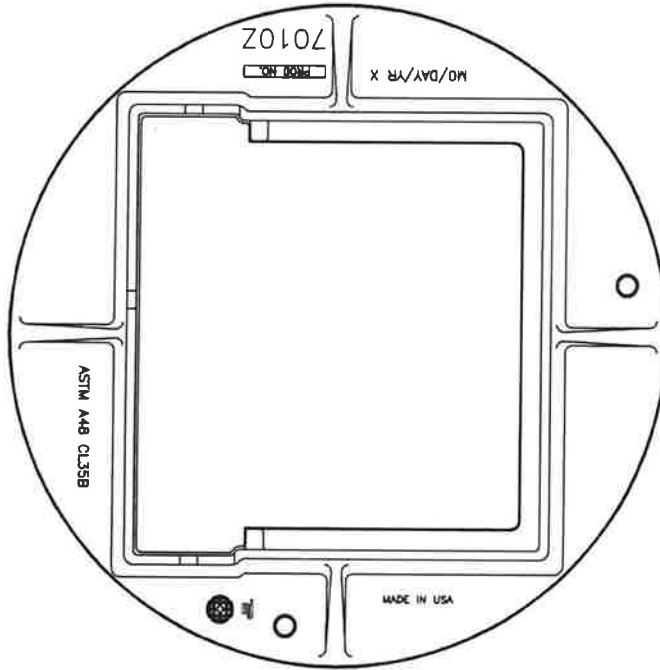

SECTION

Drawing Revision

02/21/2006 Designer: JJJ
11/14/2016 Revised By: DAE

Disclaimer

Weights (lbs./kg) dimensions (inches/mm) and drawings provided for your guidance. We reserve the right to modify specifications without prior notice.

CONFIDENTIAL: This drawing is the property of EJ GROUP, Inc. and embodies confidential information, registered marks, patents, trade secret information, and/or know how that is the property of EJ GROUP, Inc. Copyright © 2012 EJ GROUP, Inc. All rights reserved.

Contact

800 626 4653
ejco.com

7010M1 Grate

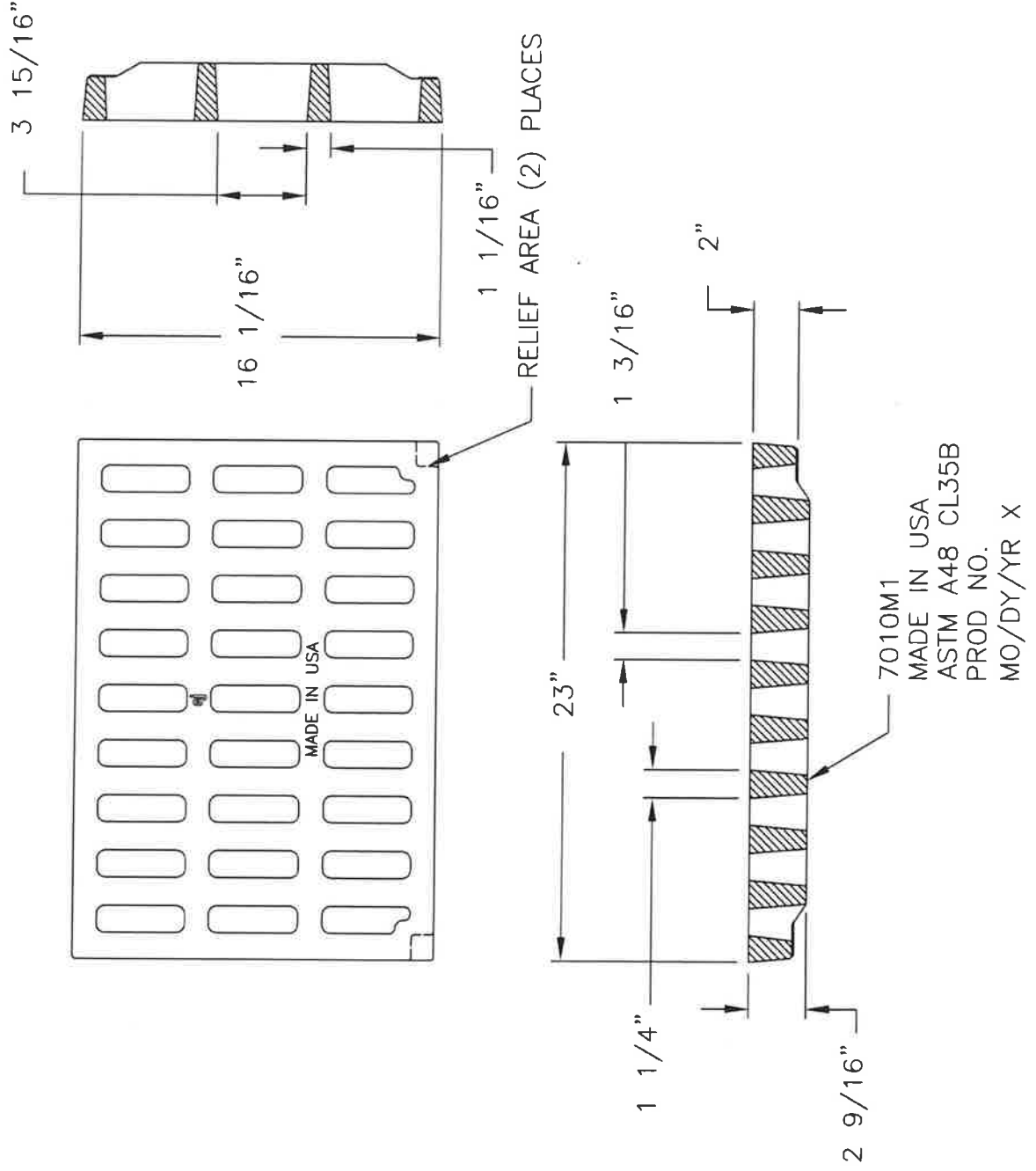

Product Number

00701030

Design Features

- Materials
Gray Iron (CL35B)
- Design Load
Heavy Duty
- Open Area
130 sq in
- Coating
Dipped
- Designates Machined Surface

Certification

-ASTM A48

-Country of Origin: USA

Weight:

- 144 lbs

Drawing Revision

12/2/2003 Designer: JJJ
3/29/2017 Revised By: DEF

Disclaimer

Weights (lbs/kg) dimensions (inches/mm) and drawings provided for your guidance. We reserve the right to modify specifications without prior notice.

CONFIDENTIAL - This drawing is the property of EJ GROUP, Inc. and embodies confidential information, registered marks, patents, trade secret information, and/or know how that is the property of EJ GROUP, Inc. Copyright © 2012 EJ GROUP, Inc. All rights reserved.

Contact

800 626 4653
ejco.com

1310Z Frame



Product Number
00131011

Design Features
-Materials
Gray Iron (CL35B)
-Design Load
Heavy Duty
-Open Area
n/a
-Coating
Undipped

- Designates Machined Surface
- Estimated Weight - 130 lbs

Certification
-ASTM A48

-Country of Origin: USA

Drawing Revision
3/16/2012 Designer DJH
12/3/2019 Revised By: MAH

Disclaimer
Weights (lbs/kg), dimensions (inches/mm) and drawings provided for your guidance. We reserve the right to modify specifications without prior notice.

CONFIDENTIAL This drawing is the property of EJ Group Inc. and embodies confidential information registered marks, patents, trade secret info, marks, and/or know how that is the property of EJ Group, Inc. Copyright © 2019 EJ Group, Inc. All rights reserved.

Contact
800 626 4653
ejco.com

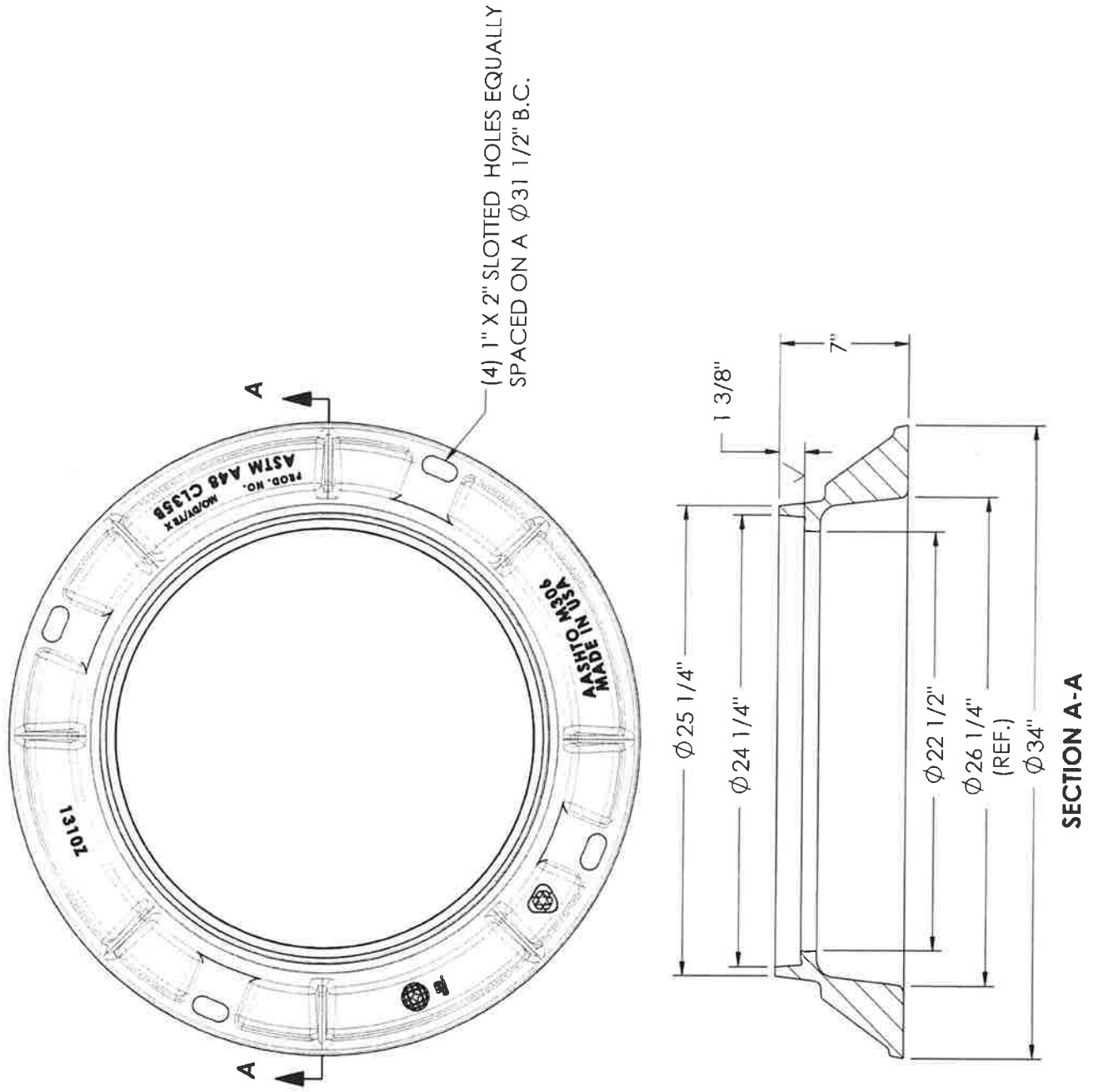

1310C2 Cover

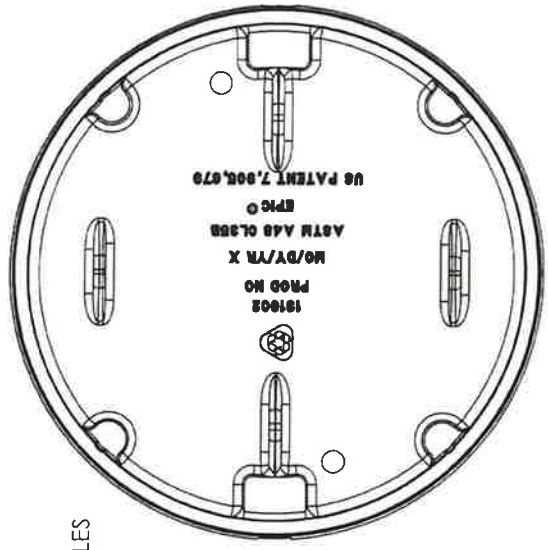
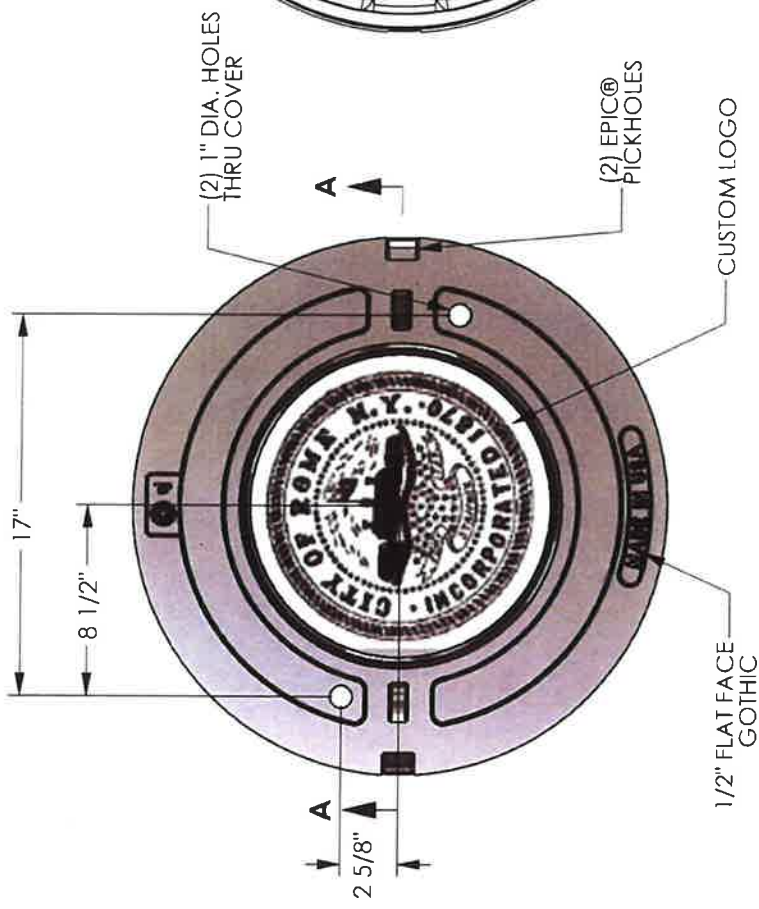

BOTTOM VIEW

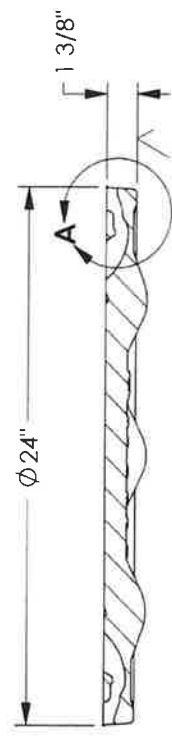

SECTION A-A

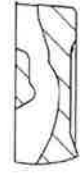

**DETAIL A
PICKHOLE**

Product Number
001310007

Design Features

- Materials
Gray Iron (CL35B)
- Design Load
Heavy Duty
- Open Area
n/a
- Coating
Unclipped
- Designates Machined Surface

Certification
-ASTM A48

-Country of Origin USA

Drawing Revision
6/3/2014 Designer MAH
Revised By

Disclaimer
Weights, tolerances, dimensions, and drawings provided for your guidance. We reserve the right to modify specifications without notice.

CONFIDENTIAL This drawing is the property of EJ Group, Inc. and embodies confidential information registered marks, patents, trade secrets, information and/or know-how that is the property of EJ Group, Inc. Copyright © 2013 EJ Group, Inc. All rights reserved.

Contact
800 626 4653
ejco.com

M5 Adjustable Steel Riser

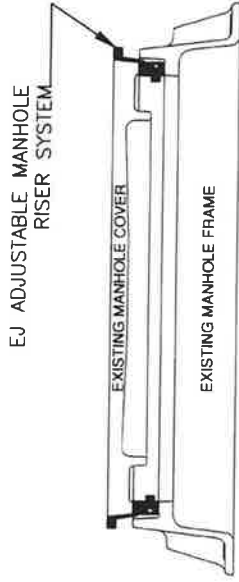
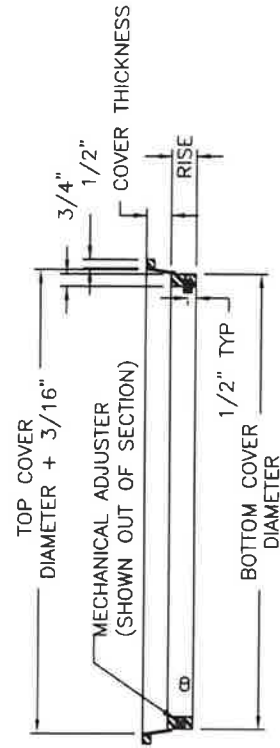
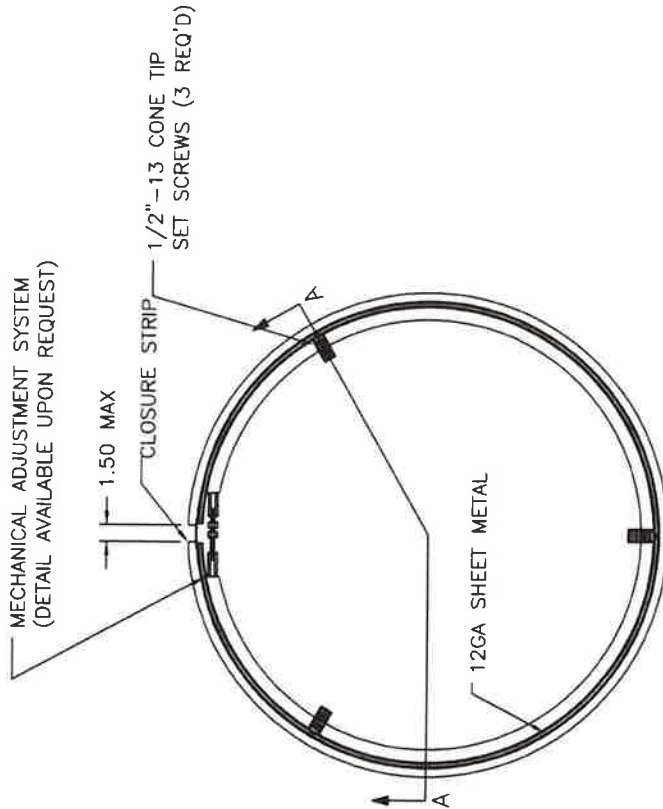

**TYPICAL INSTALLATION
SHOWING LID IN RAISED POSITION**

NOTES:

- 1.) MATERIAL SHALL MEET OR EXCEED MINIMUM REQUIREMENTS OF ASTM A36 CARBON STEEL.
- 2.) MECHANICAL ADJUSTMENT STUD IS MADE OF TYPE 304 STAINLESS STEEL.
- 3.) ALL "M5" STYLE RISERS ARE FOR HEIGHT ADJUSTMENTS EQUAL TO OR LESS THAN THE THICKNESS OF THE MANHOLE COVER.
- 4.) EACH RISER IS CUSTOM FABRICATED FROM MEASUREMENTS PROVIDED WITH EACH ORDER. REQUIRED MEASUREMENTS INCLUDE THE FOLLOWING:
 - A. EXIST. MANHOLE COVER DIAMETER - TOP & BOTTOM
 - B. EXISTING MANHOLE COVER THICKNESS
 - C. REQUIRED HEIGHT OF ADJUSTMENT
- 5.) MINIMUM RECOMMENDED HEIGHT OF ADJUSTMENT FOR REPAVING PROJECTS IS 1".
- 6.) HEIGHT ADJUSTMENTS ARE AVAILABLE IN 1/4" INCREMENTS.
- 7.) DURING INSTALLATION CHECK FOR FULL BEARING OF LOWER FRAME SECTION ON EXISTING CASTING. OVERTIGHTENING ADJUSTMENT SYSTEM MAY CAUSE UPLIFTING OF RISER.
- 8.) DIMENSIONS MAY VARY TO MEET EXISTING FIELD CONDITIONS. ANY CHANGE IN DIMENSIONS SHALL BE APPROVED BY THE OWNER.
- 9.) AFTER FABRICATION, RISERS ARE COATED WITH EITHER A WATER BASED BITUMINOUS ASPHALT EMULSION PAINT OR BASF E-COAT W/ CHARCOAL BLACK TOPCOAT.
- 10.) AVAILABLE OPTIONS IN LIEU OF CONE POINT SET SCREWS INCLUDE "L" CLIPS WITH HEX HEAD BOLTS.
- 11.) SLOPED RISERS ARE ALSO AVAILABLE.

**Product Number
M5 Riser**

Design Features

- Materials See Notes
- Design Load H20
- Open Area N/A
- Coating See Notes
- Designates Machined Surface

Certification

-Country of Origin: USA

Drawing Revision

03/27/07 Designer: CJC
01/06/14 Revised By: BDD

Disclaimer

Weights (lbs/kg), dimensions (inches/mm) and drawings provided for your guidance. We reserve the right to modify specifications without prior notice.

CONFIDENTIAL: This drawing is the property of EJ Group, Inc. and embodies confidential information, registered marks, patents, trade secret information, and/or know-how that is the property of EJ Group, Inc. Copyright © 2011 EJ Group, Inc. All rights reserved.

Contact

800 626 4653
ejco.com

7007 DURALAST Detectable Warning Plate

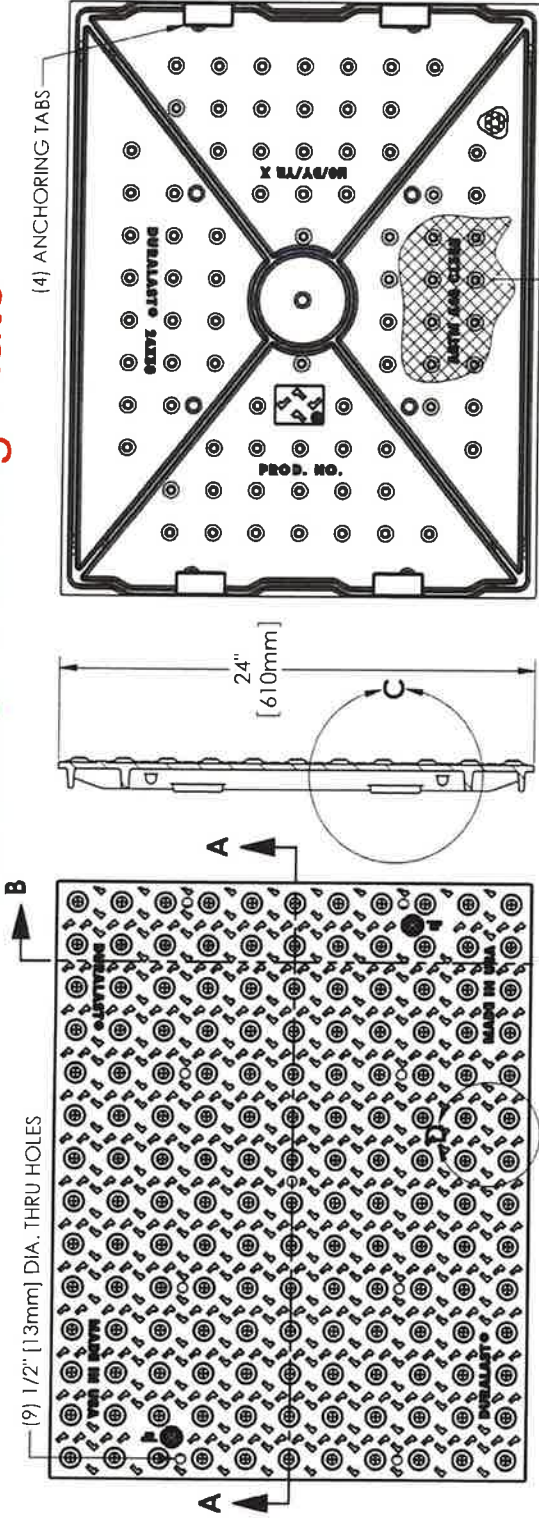

- Product Number**
00700721
- Design Features**
- Materials
Gray Iron (CL35B)
 - Load Rating
Heavy Duty
 - Open Area
n/a
 - Coating
Undipped
 - V Designates Machined Surface

- Certification**
- ASTM A48
 - AASHTO M333
 - ADA
 - CSA B651-18
 - Country of Origin USA

BOTTOM VIEW

SECTION B-B

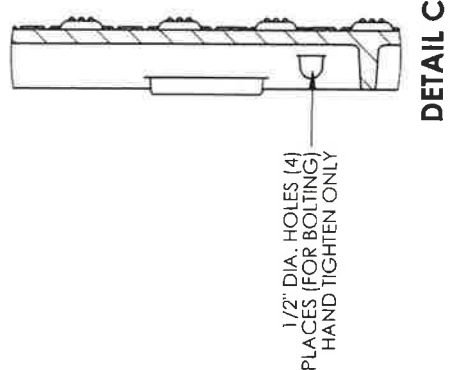
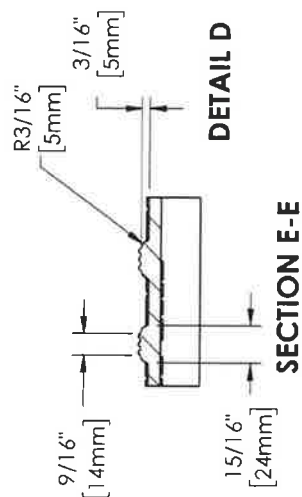
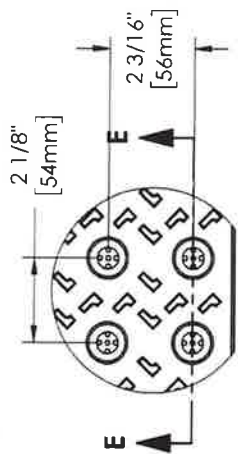
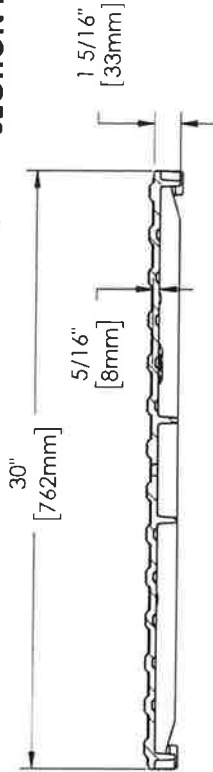

Drawing Revision
6/23/2009 Designer DEW
2/2/2022 Revised By: DAE

Disclaimer
Weights (lbs/kg), dimensions (inches/mm) and drawings provided for your guidance. We reserve the right to modify specifications without prior notice.

CONFIDENTIAL: This drawing is the property of E.J. Group, Inc. and embodies confidential information registered marks, patents, trade secret information, and/or know-how. It is the property of E.J. Group, Inc. © 2009 E.J. Group, Inc. All rights reserved.

Contact
800 626 4653
ejco.com

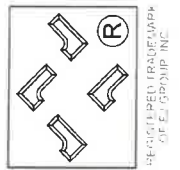

1312Z Frame



Product Number
00131211

Design Features

- Materials
Gray Iron (CL35B)
- Design Load
Heavy Duty
- Open Area
n/a
- Coating
Undipped
- √ Designates Machined Surface

Certification
-ASTM A48

Country of Origin USA

Drawing Revision
12/20/2010 Designer DEW
04/22/2014 Revised By DJH

Disclaimer
Weights (lbs/kg), dimensions (inches/mm), and drawings provided for your guidance. We reserves the right to modify specifications without prior notice.

CONFIDENTIAL This drawing is the property of E.J. Group, Inc. and embodies confidential information, registered marks, patents, trade secret information and/or know-how that is the property of E.J. Group, Inc. Copyright © 2012 E.J. Group, Inc. All rights reserved.

Contact
800.625.4653
ejco.com

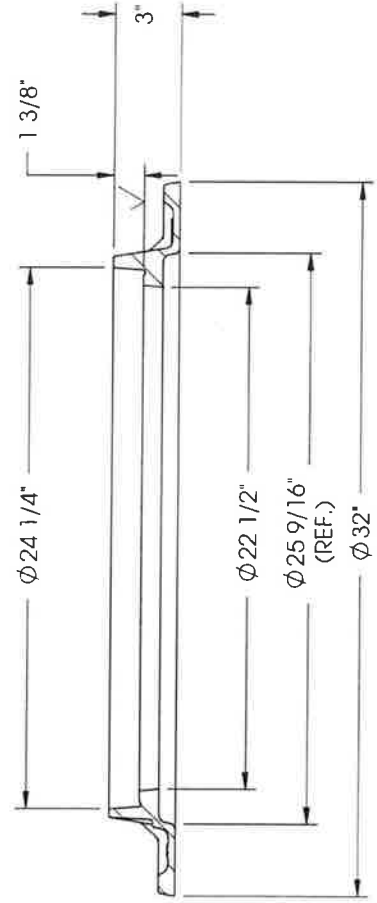
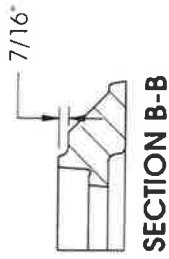
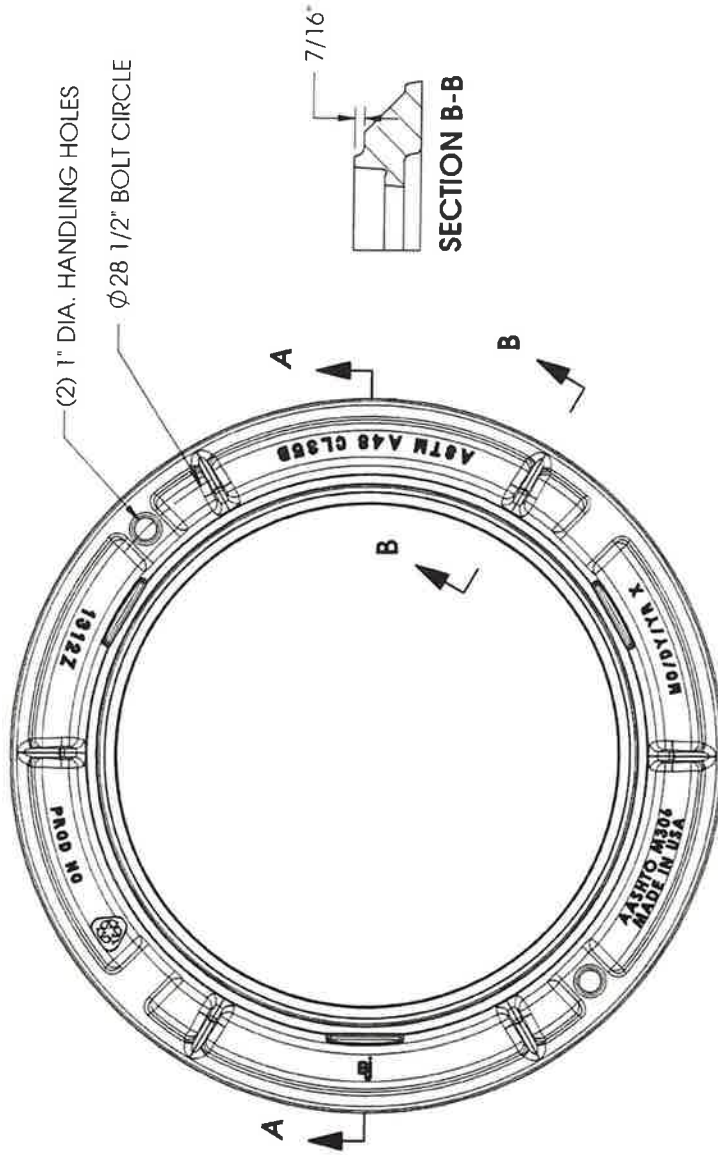

1310 Grate



Product Number
00131034

Design Features

- Materials
Gray Iron (CL35B)
- Load Rating
Heavy Duty
- Open Area
182 Sq. Inches
- Coating
Undipped
- Designates Machined Surface

Certification

- ASTM A48
- H25
- Country of Origin: USA

Drawing Revision

- 5/16/2012 Designer KK
- 2/4/2021 Revised By: DAE

Disclaimer

Weights (lbs/sq. ft), dimensions (inches/mm), and drawings provided for your guidance. We reserve the right to modify specifications without prior notice.
 PROPRIETARY: This drawing is the property of E.J. Group, Inc. and embodies confidential information, registered marks, patents, trade secret information, and/or know-how that is the property of E.J. Group, Inc. Copyright © 2012 E.J. Group, Inc. All rights reserved.

Contact

800 626 4653
ejco.com

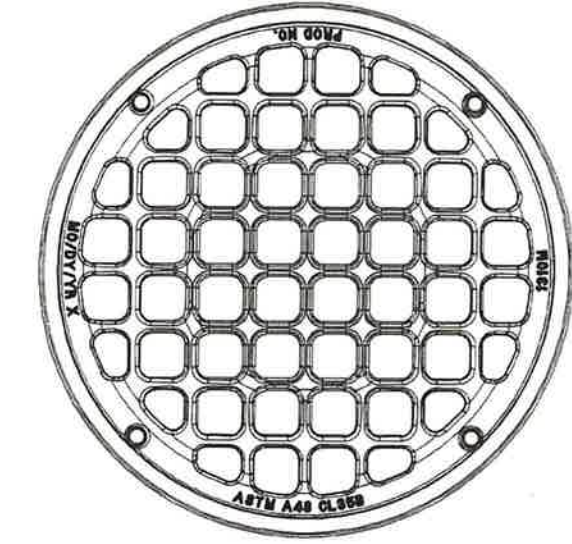

BOTTOM VIEW

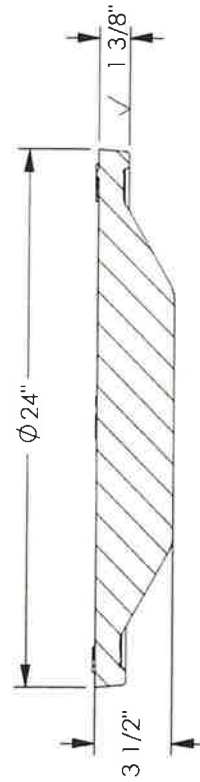
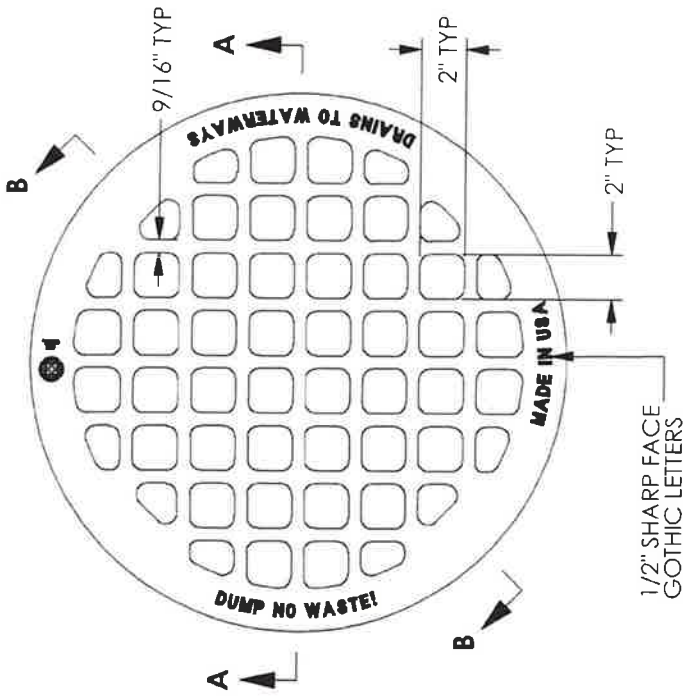

SECTION A-A

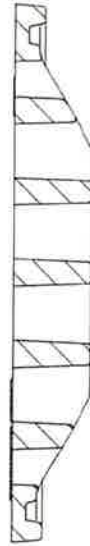

SECTION B-B

8550 Valve Box Top



VIEW OF BACK SIDE LETTERING

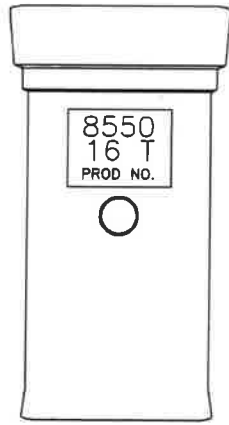

PLAN VIEW

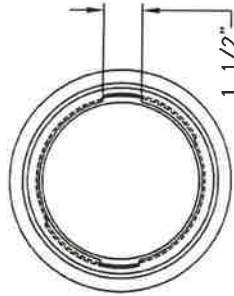

TOP VIEW

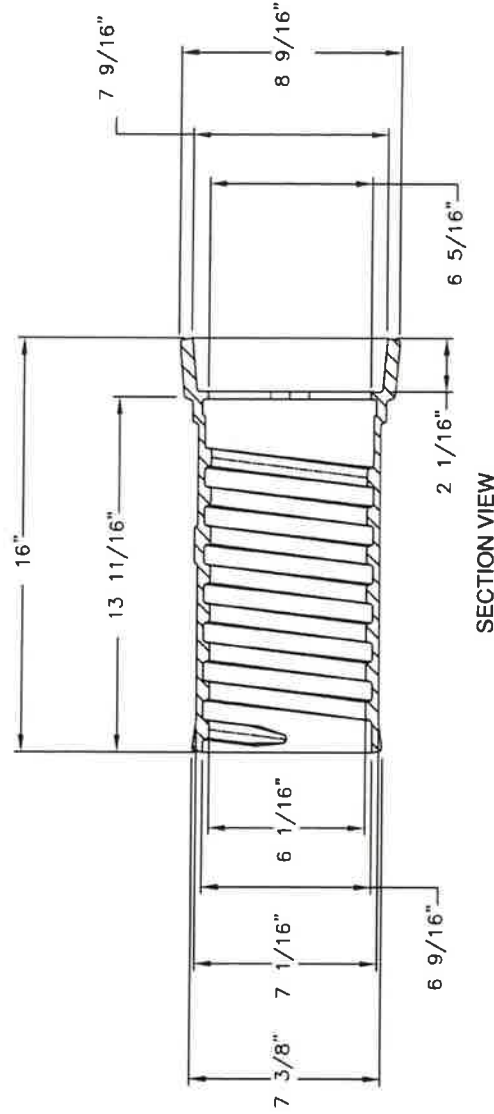

SECTION VIEW

Product Number

85507016

Design Features

- Materials Gray Iron (CL35B)
- Design Load Heavy Duty
- Open Area n/a
- Coating Dipped
- Designates Machined Surface

Certification

-ASTM A48

-Country of Origin: USA

Drawing Revision

3/31/2006 Designer: TCL
10/25/2012 Revised By: JJJ

Disclaimer

Weights (lbs./kg) dimensions (inches/mm) are subject to change provided for your guidance. We reserve the right to modify specifications without prior notice.

CONFIDENTIAL: This drawing is the property of EJ GROUP, Inc., and embodies confidential information, registered marks, patents, trade secret information, and/or know how that is the property of EJ GROUP, Inc. Copyright © 2011 EJ GROUP, Inc. All rights reserved

Contact

800 626 4653
ejco.com

8550 Valve Box Top



VIEW OF BACK SIDE LETTERING

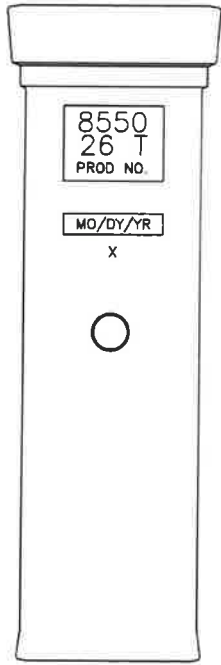

PLAN VIEW

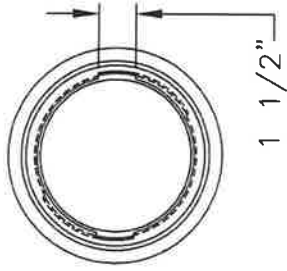

TOP VIEW

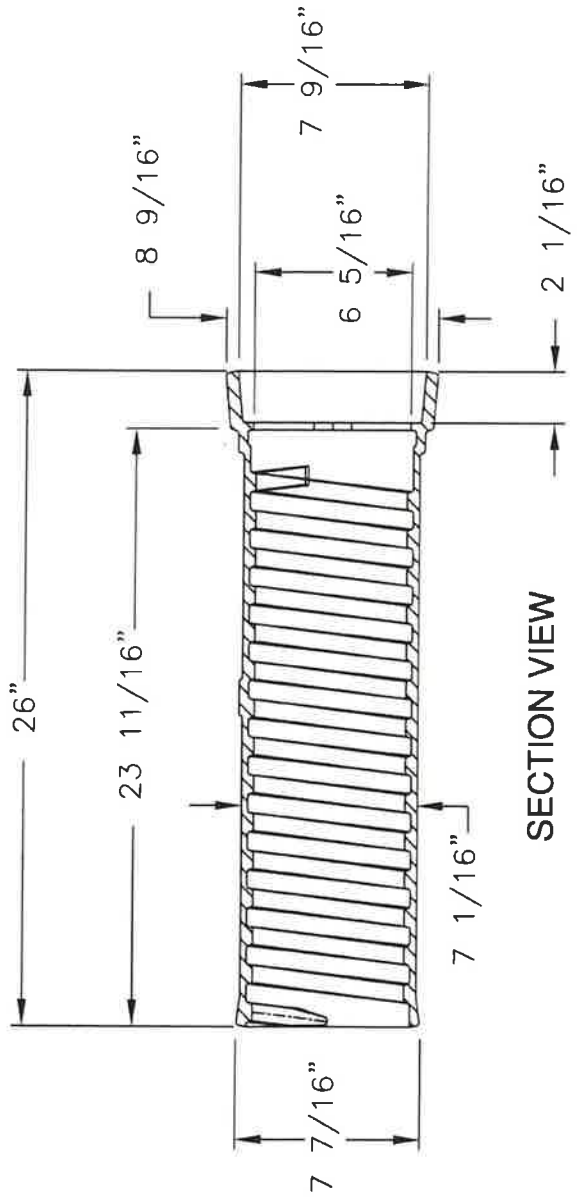

SECTION VIEW

Product Number
85507026

Design Features

- Materials
Gray Iron (CL35B)
- Design Load
Heavy Duty
- Open Area
n/a
- Coating
Dipped
- Designates Machined Surface

Certification

- ASTM A48
- Country of Origin: USA

Drawing Revision

03/31/2006 Designer: TCL
10/25/2012 Revised By: SDC

Disclaimer

Weights (lbs., kg) dimensions (inches/mm) and tolerances are provided for your guidance. We reserve the right to modify specifications without prior notice.

CONFIDENTIAL: This drawing is the property of EJ GROUP, Inc., and embodies confidential information, registered marks, patents, trade secret information, and/or know how that is the property of EJ GROUP, Inc. Copyright © 2011 EJ GROUP, Inc. All rights reserved.

Contact

800 626 4653
ejco.com

8560 Valve Box Bottom

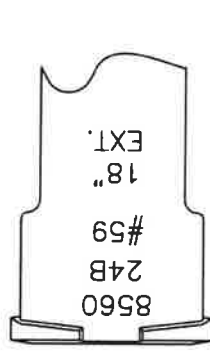

VIEW OF BACK SIDE LETTERING

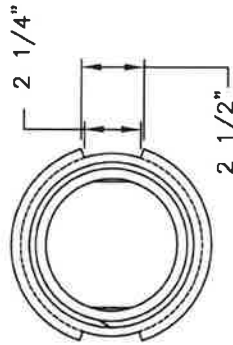

END VIEW

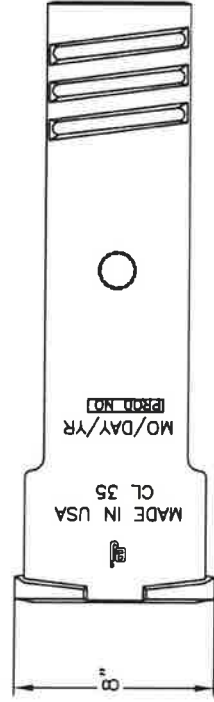

PLAN VIEW

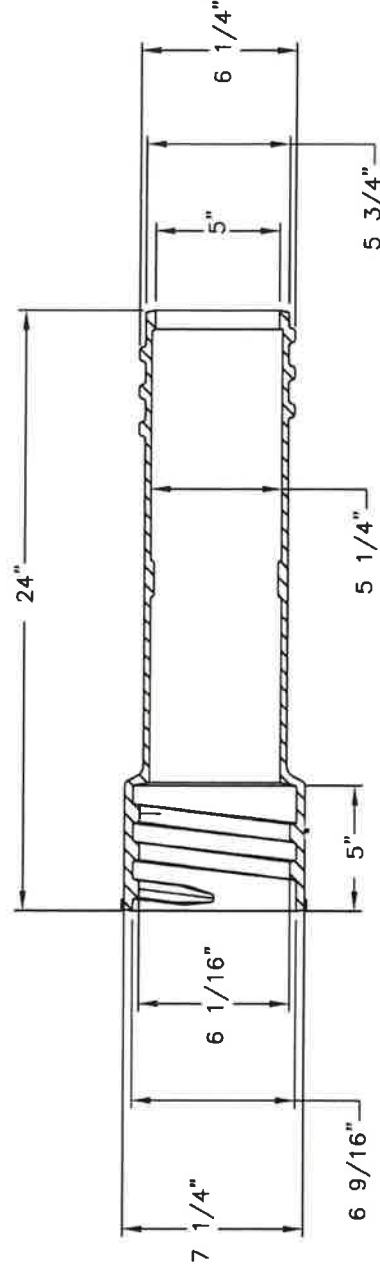

SECTION VIEW

Product Number

85606024

Design Features

- Materials: Gray Iron (CL35B)
- Design Load: Heavy Duty
- Open Area: n/a
- Coating: Dipped
- Designates Machined Surface

Certification

-ASTM A48

-Country of Origin: USA

Drawing Revision

03/07/2002 Designer: TCL
01/07/2014 Revised By: DAE

Disclaimer

Weights (lbs) dimensions (inches/mm) and drawings provided for your guidance. We reserve the right to modify specifications without prior notice.
CONFIDENTIAL: This drawing is the property of EJ GROUP, Inc., and embodies confidential information, registered marks, patents, trade secret information, and/or know how that is the property of EJ GROUP, Inc. Copyright © 2011 EJ GROUP, Inc. All rights reserved

Contact

800 626 4653
ejco.com

8560 #6 Valve Box Base

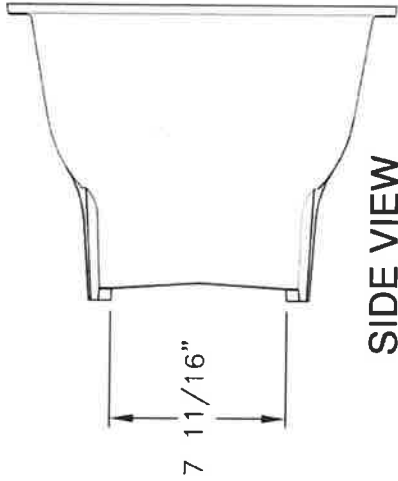

Product Number
85605006

Design Features

- Materials
Gray Iron (CL35B)
- Design Load
Heavy Duty
- Open Area
n/a
- Coating
Dipped
- Designates Machined Surface

Certification
- ASTM A48

-Country of Origin: USA

Drawing Revision

5/1/2003 Designer: TCL
8/6/2020 Revised By: DAE

Disclaimer

Weights (lbs./kg) dimensions (inches/mm) and drawings provided for your guidance. We reserve the right to modify specifications without prior notice.

CONFIDENTIAL: This drawing is the property of EJ GROUP, Inc., and embodies confidential information, registered marks, patents, trade secret information, and/or know-how that is the property of EJ GROUP, Inc. Copyright © 2012 EJ GROUP, Inc. All rights reserved.

Contact

800 626 4653
ejco.com

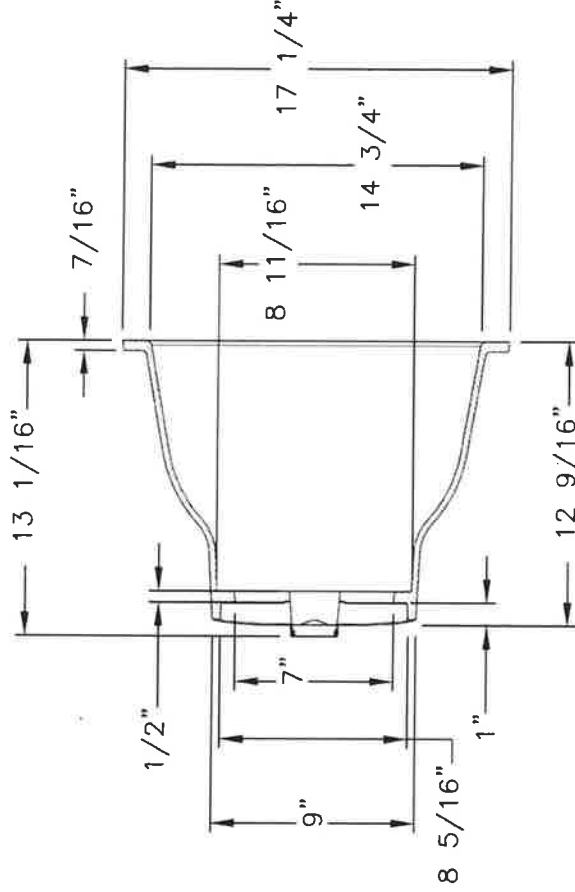
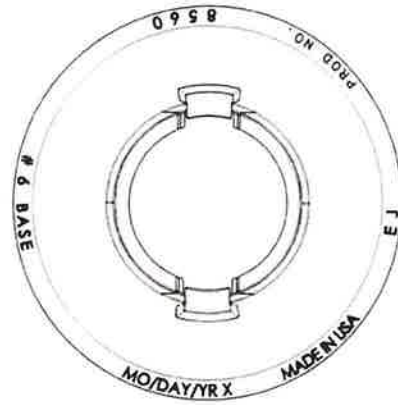

TOP VIEW

SECTION VIEW

8550 Valve Box Top



Product Number
85507016

Design Features

- Materials
Gray Iron (CL35B)
- Design Load
Heavy Duty
- Open Area
n/a
- Coating
Dipped
- Designates Machined Surface

Certification

- ASTM A48
- Country of Origin: USA

Drawing Revision

3/31/2006 Designer: TCL
10/25/2012 Revised By: JJJ

Disclaimer

Weights (lbs.) dimensions (inches/mm) and drawings provided for your guidance. We reserve the right to modify specifications without prior notice.

CONFIDENTIAL: This drawing is the property of EJ GROUP, Inc., and embodies confidential information, registered marks, patents, trade secret information, and/or know how that is the property of EJ GROUP, Inc. Copyright © 2011 EJ GROUP, Inc. All rights reserved.

Contact

800 626 4653
ejco.com

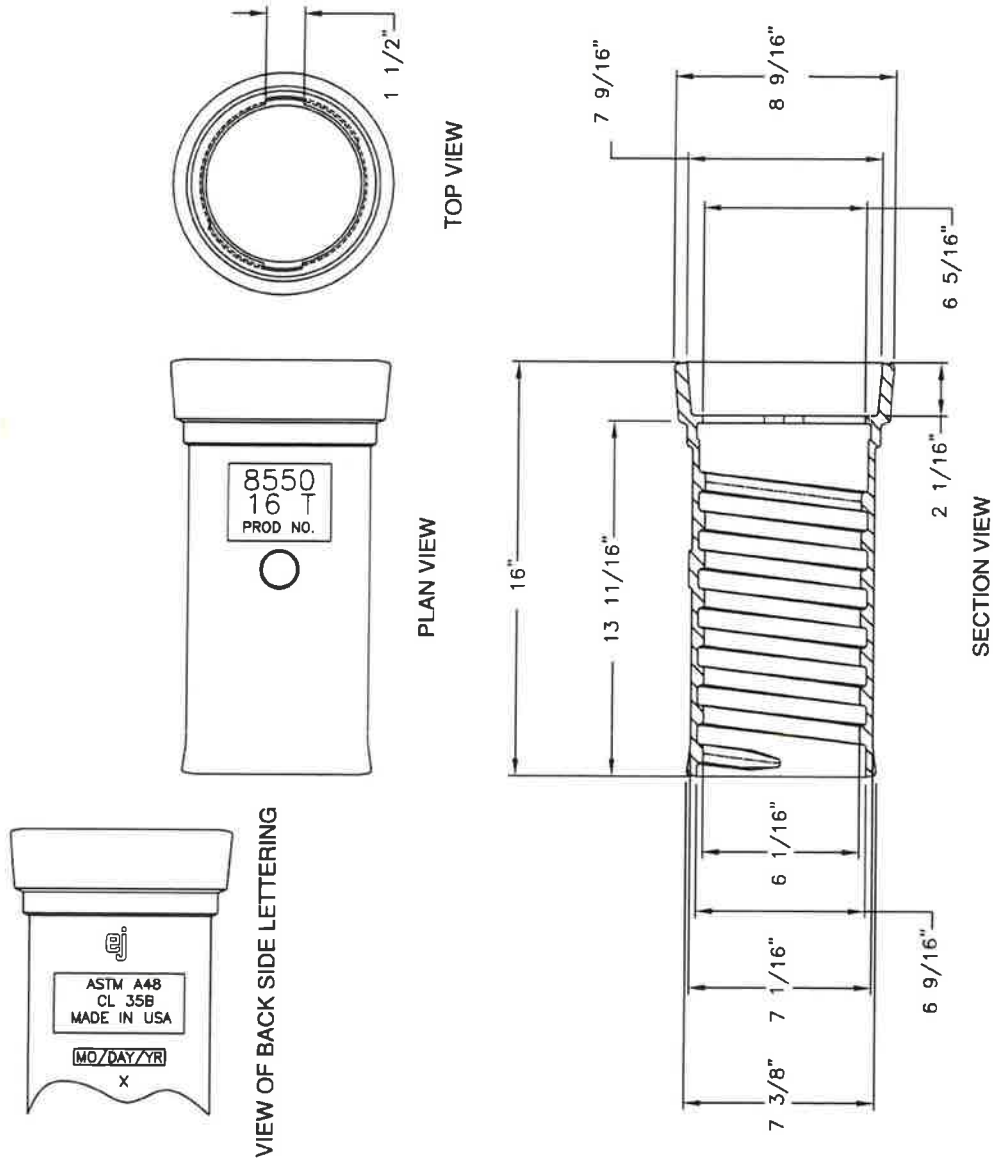

6800 Valve Box Cover

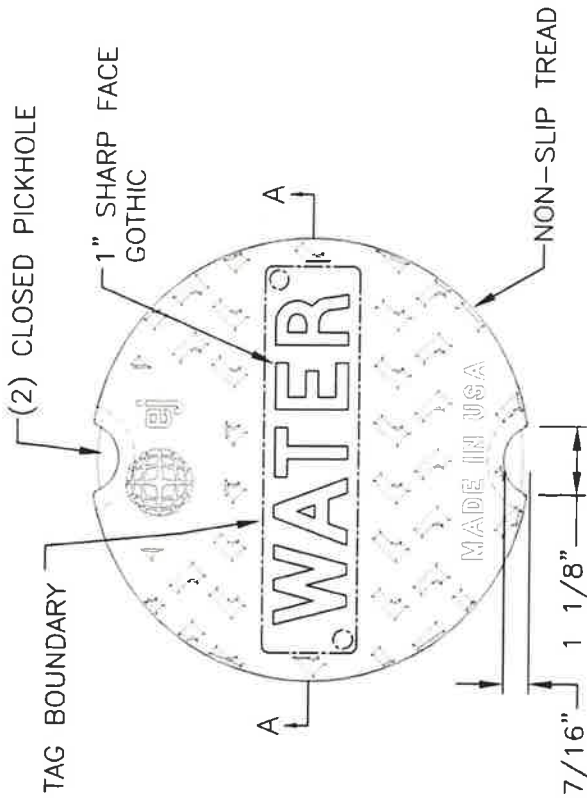

PLAN VIEW

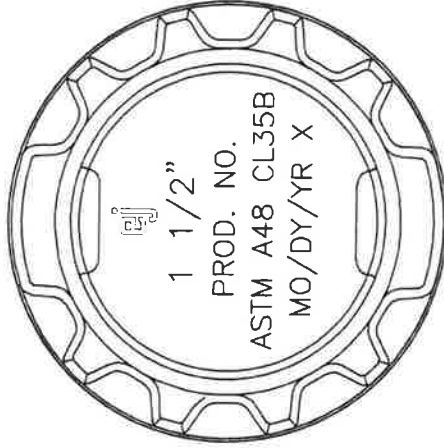

BOTTOM VIEW

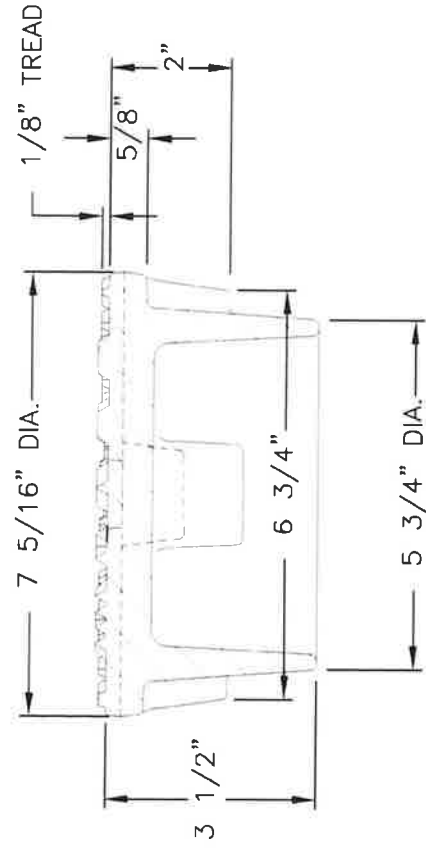

COVER SECTION

Product Number

06800001

Design Features

- Materials
Gray Iron (CL35B)
- Design Load
Heavy Duty
- Open Area
n/a
- Coating
Dipped
- Designates Machined Surface

Certification

- ASTM A48
- AASHTO M306
- Country of Origin: USA

Drawing Revision

1/25/2005 Designer: TCL
12/9/2020 Revised By: MAH

Disclaimer

Weights (lbs./kg), dimensions (inches/mm) and drawings provided for your guidance. We reserve the right to modify specifications, without prior notice.

CONFIDENTIAL: This drawing is the property of EJ GROUP, Inc., and embodies confidential information, registered marks, patents, trade secret information, and/or know how that is the property of EJ GROUP, Inc. Copyright © 2011 EJ GROUP, Inc. All rights reserved.

Contact

800 626 4653
ejco.com

Document A310™ – 2010

Conforms with The American Institute of Architects AIA Document 310

Bond Number: 02213-CNA-23-28

Bid Bond

CONTRACTOR:

(Name, legal status and address)

EJ USA, Inc.
301 Spring Street
East Jordan, MI 49727

OWNER:

(Name, legal status and address)

City of Rome
198 North Washington Street
Rome, NY 13440

SURETY:

(Name, legal status and principal place of business)

Western Surety Company
151 N Franklin Street
Chicago, IL 60606
State of Inc: South Dakota

This document has important legal consequences. Consultation with an attorney is encouraged with respect to its completion or modification.

Any singular reference to Contractor, Surety, Owner or other party shall be considered plural where applicable.

BOND AMOUNT: Five Percent of Amount Bid (5%)

PROJECT:

(Name, location or address, and Project number, if any)

SUPPLY AND DELIVER STEEL CASTINGS FOR STRUCTURES, RFB - 2024 - 002 - City of Rome, New York

The Contractor and Surety are bound to the Owner in the amount set forth above, for the payment of which the Contractor and Surety bind themselves, their heirs, executors, administrators, successors and assigns, jointly and severally, as provided herein. The conditions of this Bond are such that if the Owner accepts the bid of the Contractor within the time specified in the bid documents, or within such time period as may be agreed to by the Owner and Contractor, and the Contractor either (1) enters into a contract with the Owner in accordance with the terms of such bid, and gives such bond or bonds as may be specified in the bidding or Contract Documents, with a surety admitted in the jurisdiction of the Project and otherwise acceptable to the Owner, for the faithful performance of such Contract and for the prompt payment of labor and material furnished in the prosecution thereof; or (2) pays to the Owner the difference, not to exceed the amount of this Bond, between the amount specified in said bid and such larger amount for which the Owner may in good faith contract with another party to perform the work covered by said bid, then this obligation shall be null and void, otherwise to remain in full force and effect. The Surety hereby waives any notice of an agreement between the Owner and Contractor to extend the time in which the Owner may accept the bid. Waiver of notice by the Surety shall not apply to any extension exceeding sixty (60) days in the aggregate beyond the time for acceptance of bids specified in the bid documents, and the Owner and Contractor shall obtain the Surety's consent for an extension beyond sixty (60) days.

If this Bond is issued in connection with a subcontractor's bid to a Contractor, the term Contractor in this Bond shall be deemed to be Subcontractor and the term Owner shall be deemed to be Contractor.

When this Bond has been furnished to comply with a statutory or other legal requirement in the location of the Project, any provision in this Bond conflicting with said statutory or legal requirement shall be deemed deleted herefrom and provisions conforming to such statutory or other legal requirement shall be deemed incorporated herein. When so furnished, the intent is that this Bond shall be construed as a statutory bond and not as a common law bond.

Signed and sealed this 13th day of March, 2024

(Witness)

(Witness) Olivia Spada

EJ USA, Inc.
(Principal)  (Seal)
(Title) Vice President & General Manager
Western Surety Company
(Surety)  (Seal)
(Title) Rebecca E. Johnson, Attorney-in-Fact

State of Connecticut }
County of Hartford } ss:

On March 13, 2024, before me, a Notary Public in and for said County and State, residing therein, duly commissioned and sworn, personally appeared

Rebecca E Johnson

known to me to be Attorney-in-Fact of Western Surety Company
the corporation described in and that executed the within and foregoing instrument, and known to me to be the person who executed the said instrument in behalf of the said corporation, and he duly acknowledged to me that such corporation executed the same.

IN WITNESS WHEREOF, I have hereunto set my hand and affixed my official seal, the day and year stated in this certificate above.

My Commission Expires November 30, 2027

Angela O'Hara

Angela O'Hara

Notary Public



Western Surety Company

POWER OF ATTORNEY APPOINTING INDIVIDUAL ATTORNEY-IN-FACT

Know All Men By These Presents, That WESTERN SURETY COMPANY, a South Dakota corporation, is a duly organized and existing corporation having its principal office in the City of Sioux Falls, and State of South Dakota, and that it does by virtue of the signature and seal herein affixed hereby make, constitute and appoint Rebecca E Johnson

, Individually

of Hartford, CT, its true and lawful Attorney(s)-in-Fact with full power and authority hereby conferred to sign, seal and execute for and on its behalf bonds, undertakings and other obligatory instruments of similar nature

- In Unlimited Amounts -

Surety Bond Number: 02213-CNA-23-28

Principal: EJ USA, Inc.

Obligee: City of Rome, NY

and to bind it thereby as fully and to the same extent as if such instruments were signed by a duly authorized officer of the corporation and all the acts of said Attorney, pursuant to the authority hereby given, are hereby ratified and confirmed.

This Power of Attorney is made and executed pursuant to and by authority of the By-Law and Resolutions printed on the reverse hereof, duly adopted, as indicated, by the shareholders of the corporation.

In Witness Whereof, WESTERN SURETY COMPANY has caused these presents to be signed by its Vice President and its corporate seal to be hereto affixed on this 27th day of April, 2023.

WESTERN SURETY COMPANY



Larry Kasten
Larry Kasten, Vice President

State of South Dakota)
County of Minnehaha) ss

On this 27th day of April, 2023, before me personally came Larry Kasten, to me known, who, being by me duly sworn, did depose and say: that he resides in the City of Sioux Falls, State of South Dakota; that he is the Vice President of WESTERN SURETY COMPANY described in and which executed the above instrument; that he knows the seal of said corporation; that the seal affixed to the said instrument is such corporate seal; that it was so affixed pursuant to authority given by the Board of Directors of said corporation and that he signed his name thereto pursuant to like authority, and acknowledges same to be the act and deed of said corporation.

My commission expires

March 2, 2026

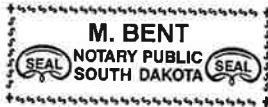

M. Bent

M. Bent, Notary Public

CERTIFICATE

I, L. Nelson, Assistant Secretary of WESTERN SURETY COMPANY do hereby certify that the Power of Attorney hereinabove set forth is still in force, and further certify that the By-Law and Resolutions of the corporation printed on the reverse hereof is still in force. In testimony whereof I have hereunto subscribed my name and affixed the seal of the said corporation this 13th day of March, 2024.



WESTERN SURETY COMPANY

L. Nelson

L. Nelson, Assistant Secretary

Authorizing By-Laws and Resolutions

ADOPTED BY THE SHAREHOLDERS OF WESTERN SURETY COMPANY

This Power of Attorney is made and executed pursuant to and by authority of the following By-Law duly adopted by the shareholders of the Company.

Section 7. All bonds, policies, undertakings, Powers of Attorney, or other obligations of the corporation shall be executed in the corporate name of the Company by the President, Secretary, and Assistant Secretary, Treasurer, or any Vice President, or by such other officers as the Board of Directors may authorize. The President, any Vice President, Secretary, any Assistant Secretary, or the Treasurer may appoint Attorneys in Fact or agents who shall have authority to issue bonds, policies, or undertakings in the name of the Company. The corporate seal is not necessary for the validity of any bonds, policies, undertakings, Powers of Attorney or other obligations of the corporation. The signature of any such officer and the corporate seal may be printed by facsimile.

This Power of Attorney is signed by Larry Kasten, Vice President, who has been authorized pursuant to the above Bylaw to execute power of attorneys on behalf of Western Surety Company.

This Power of Attorney may be signed by digital signature and sealed by a digital or otherwise electronic-formatted corporate seal under and by the authority of the following Resolution adopted by the Board of Directors of the Company by unanimous written consent dated the 27th day of April, 2022:

“RESOLVED: That it is in the best interest of the Company to periodically ratify and confirm any corporate documents signed by digital signatures and to ratify and confirm the use of a digital or otherwise electronic-formatted corporate seal, each to be considered the act and deed of the Company.”

